

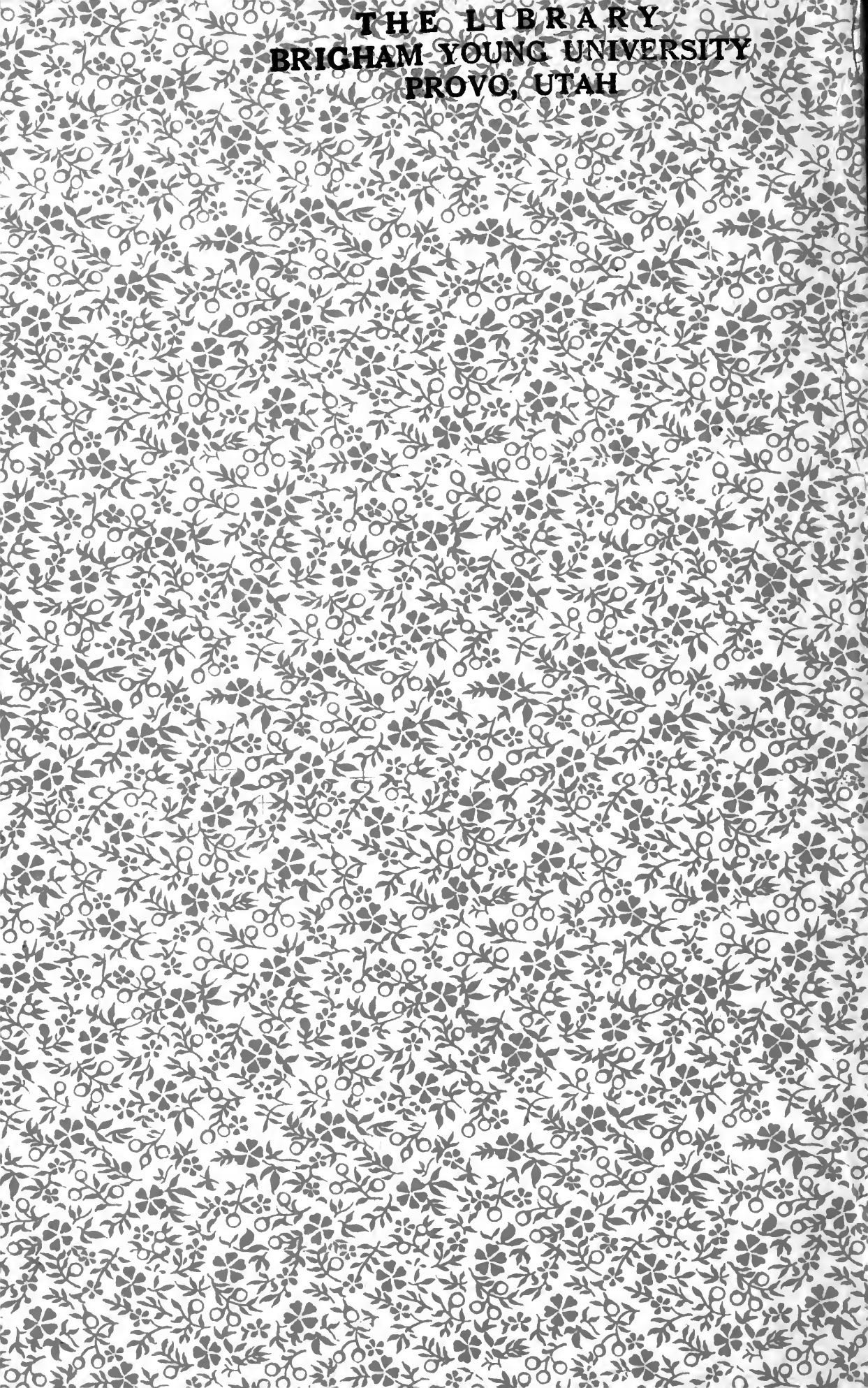

THE LIBRARY  
BRIGHAM YOUNG UNIVERSITY  
PROVO, UTAH

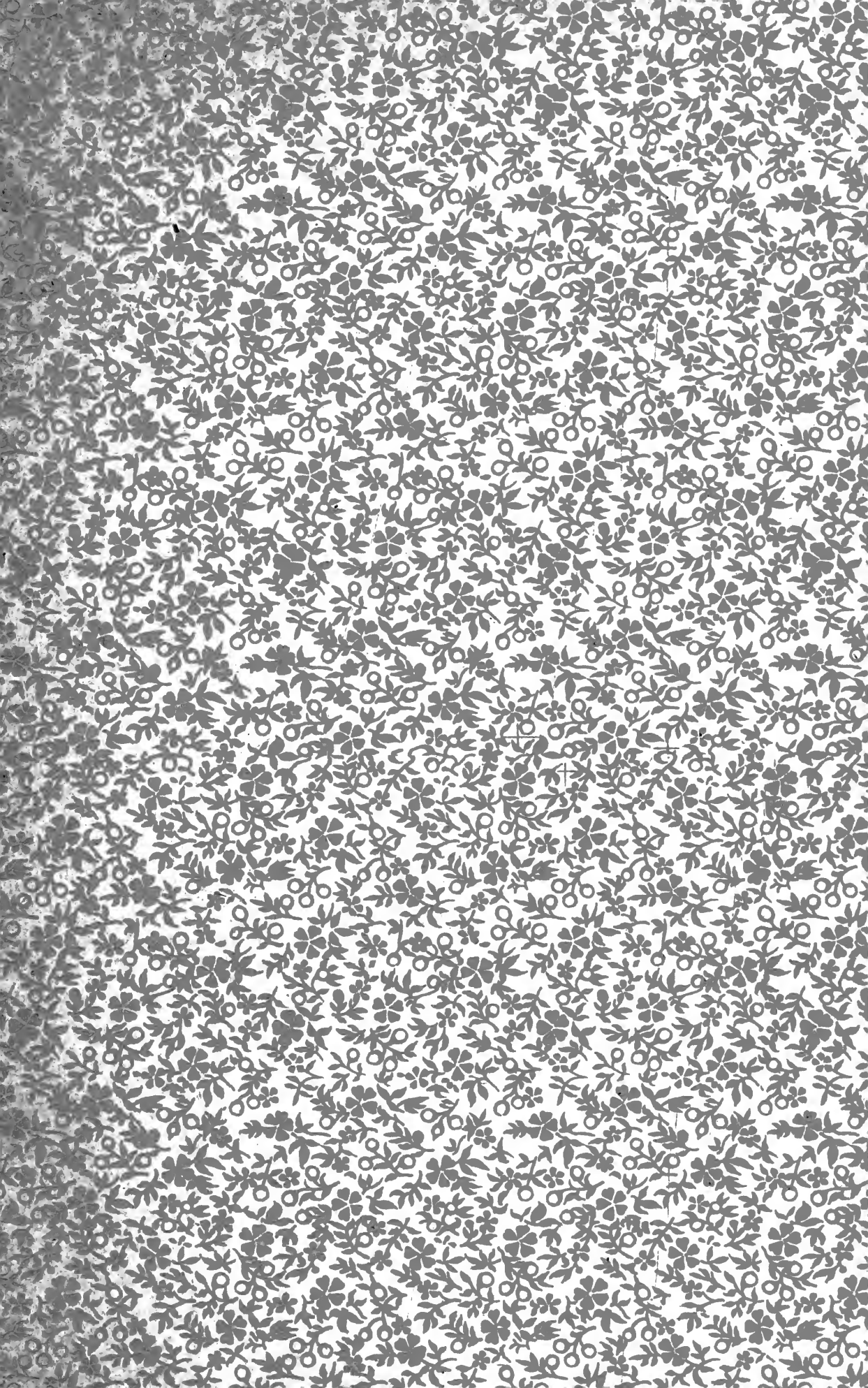





Am 35a  
V. 31

## *The Right Beginning*

presages the right ending. Good negatives depend upon the quality of the film employed and are essential to photographic success.

### *Ansco Speedex Film*

assures good negatives under all reasonable conditions of lighting and exposure.

### *Speed*

is essential for the avoidance of under-exposure.

### *Color Value Qualities*

must be present to render faithfully in monotint the delicate balance of color and light and shade in nature.



### *Ansco Speedex Film*

in your camera means making the most of the most of your pictures.

*Write for Ansco  
Film Book*

# Ansco Company

Binghamton, N. Y.

## *The Finished Print*

is the measure of your photographic achievements. Every negative gives not only a good print, but a print which brings out all that is in the negative if you use

### *Cyko Paper*

CYKO for contact printing is made in five surfaces to suit the subject of the picture and in four grades to suit the quality of the negative;

### *Normal Cyko*

for negatives of normal density and gradation,

### *Contrast Cyko*

for weak and excessively soft negatives,

### *Soft Cyko*

for vigorous or contrastive negatives,

### *Professional Cyko*

for portrait negatives and subjects demanding richness of quality with soft, progressive gradation of tone.



*Write for Cyko  
Manual*

**AnSCO Company**

Binghamton, N. Y.

## *A Good Enlargement*

from *every* negative is possible when ENLARGING CYKO is the paper used, because it is made in two grades of contrast —

### *Enlarging Cyko Soft*

for negatives of normal gradation and balance,

### *Enlarging Cyko Contrast*

for those weak, thin, undertimed negatives, heretofore discarded as failures so far as satisfactory enlargements were concerned.

### *Enlarging Cyko*

is a rapid-printing chloride—not a bromide—paper which yields prints wherein are retained and enhanced the tonal qualities of contact prints.



*Write for complete  
literature*

**AnSCO Company**

Binghamton, N. Y.

## *A Camera Small in Size*

but great in its accomplishments is the

### *AnSCO V-P No. 0*

A vest-pocket camera, watchlike in its accuracy, equipped with anastigmat lens made fully efficient through an ingenious device for instant and accurate focusing—without which device an anastigmat is no better than a cheap lens.

It makes  $1\frac{5}{8} \times 2\frac{1}{2}$  pictures which enlarge successfully on Enlarging CYKO.

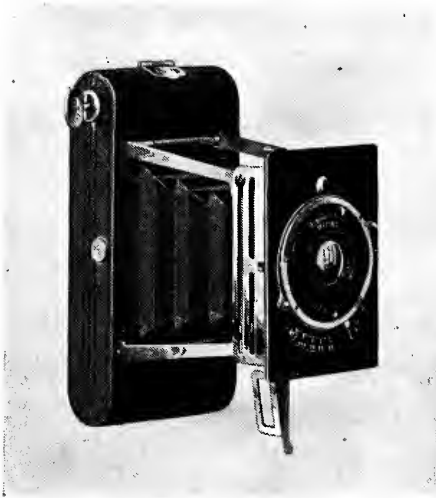

### *AnSCO V-P No. 0*

with single lens, fixed focus, \$7.

With focusing device, Extraspeed Bionic Shutter and Modico Anastigmat lens, F 7.5, \$15; AnSCO Anastigmat lens, F 6.3, \$25.

*Write for complete catalog*

## **AnSCO Company**

Binghamton, N. Y.



# “Let the User Judge”

## Wollensak Lenses

IRRESPECTIVE

of your —

REQUIREMENT

there is among the complete line a

# Wollensak

Lens and Shutter

that will fill it satisfactorily —

*Send to-day for complete catalogue describing in detail:*

### LENSES:

Velostigmat Series I F:6.3      Verito Diffused Focus F:4  
Velostigmat Series II F:4.5      Vitax Portrait F:3.8  
Velostigmat Series III F:9.5      Vesta Portrait F:5  
Vinc Anastigmat F:6.3–F:6.8      Voltas F:8  
Versar Portrait and View F:6      Wide Angle F:16

SHUTTERS— Optimo      Regno      Ultro  
                         Auto      Victo      Studio

## WOLLENSAK OPTICAL CO.

1390 CLINTON AVENUE, N.      ::      ROCHESTER, N. Y.

*Ready in January*  
ORDER YOUR COPY IN ADVANCE

---

**PENROSE'S  
PROCESS  
YEAR-BOOK, 1917**

Edited by William Gamble

A profusely illustrated review of the progress of graphic arts.

Papers by practical workers on reproduction processes, illustration and advertising work of all kinds.

Examples of many modern methods of reproduction in black and white and colors, photogravures and other processes of today.

Full of useful information and helpful suggestions for photographers, process workers, engravers, advertisers, publishers and all interested in publishing.

---

*Price \$3.00 exprepaid to any address.  
The American Edition is limited.*

**Tennant & Ward, American Agents**  
103 Park Avenue - - New York

# NEW ROSS LENSES

Cover Perfectly with Brilliant Definition and Are Extremely Rapid. Adaptable to All Modern Cameras.

## ROSS' New "XPRES" PATENT

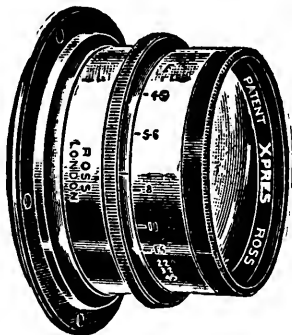

Working at full aperture.  
For Studio Portraits and Groups and for all work requiring extreme rapidity.  
Exceptionally Brilliant.  
Definition to margins.

**F/4-5**

Full Aperture

12-inch "XPRES"  
THE LENS  
for Cabinets and Whole-plate Groups.  
Admirable for Reflex and Hand Cameras.

**F/4-5**

## ROSS' New "TELECENTRIC" Patent

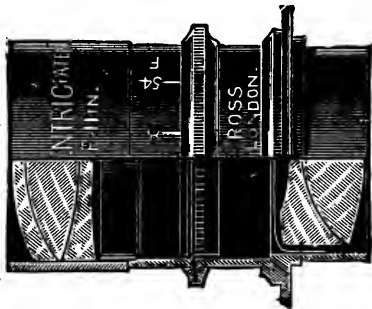

Large Image with Short Camera Extension.  
Critical Definition at full aperture.  
Shortened Exposures Ideal for Sporting Events.  
Inexpensive Studio Lens.  
Covering to margins.

**F/5-4**

Two Series

**F/6-8**

## ROSS' New "COMBINABLES" Patent

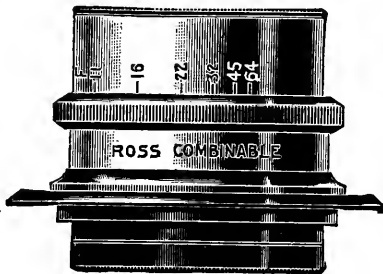

**F/11**

Singles and Doublets

**F/5-5**

The Singles are the most Rapid Single Anastigmats, perfectly corrected, giving Critical Definition to the margins without distortion—For Landscapes, Large Portraits, and Groups. The Universal Doublets are specially suitable for Portraits and Groups in the Studio and all outdoor Photography, Interiors, Copying, etc.

For Full Particulars see Ross' New Price List, sent free on Application.

American Agents

**GEORGE MURPHY, Inc.**

57 East Ninth Street

NEW YORK

# The Secret of Exposure

PRACTICAL PHOTOGRAPHY No. 1

If exposure is correct, all other steps in the making of a good negative are purely mechanical; if not correct, no after manipulation of the negative will bring perfect results. Don't waste plates and films making exposures by guesswork. Send for this book and learn how to make a good negative every time. It discusses exposure thoroughly and gives a complete system, easily understood, for obtaining correct exposure under all conditions, using any plate or film on the American market. Concluding with a clear discussion of the use of exposure meters, it is the most practical complete treatise on the subject ever written. It is a picture maker and a money saver.

**Bound in paper covers, 25c;  
in cloth 50c.**

# Beginners' Troubles

PRACTICAL PHOTOGRAPHY No. 2

The making of pictures at home is the most interesting part of photography. Like anything else, you have to learn how, and in so doing will waste a lot of time and material. Fortunately, every photographer goes through practically the same experiences, meets the same problems, and must solve them in the same manner. These common causes of failure have been considered fully in this useful volume. By reading it carefully, and referring to it constantly when picture making is first attempted, the beginner can make good pictures from the start, and waste a minimum of time and material. Although written primarily as a guide for the novice, it contains an enormous amount of practical help for the expert. Order today.

**Bound in paper covers, 25c;  
in cloth 50c.**

# How to Choose and Use a Lens

PRACTICAL PHOTOGRAPHY No. 3

Every successful worker—which you desire to be—must know what his lens can do and how it may be used to best advantage. *He must.* This volume explains the particular qualities of lenses now used in photography, and deals more particularly with the more modern types, their differences and relative advantages. It not only answers the questions that will arise in the mind of the practical worker, but is recommended for the careful study of the man who is about to purchase a high grade outfit, and must understand the lens question if an intelligent choice is to be made. The expenditure of a quarter may save several dollars; it is a common occurrence for a man to buy an outfit unsuited for the work in which he is interested. *You need this book.*

**Bound in paper covers, 25c;  
in cloth 50c.**

# How to Make Prints in Colors

PRACTICAL PHOTOGRAPHY No. 4

Anyone can make prints in colors if he can make a good black and white print. You probably have a number of pictures that would look especially well in some color beside black and white. Or you may desire to take up some of the more advanced methods of producing pictures in natural colors, or on special mediums. This book explains the toning of a standard black and white print to every possible hue, the manipulation of various mediums such as carbon, gum, bromoil, and the like, and takes up the latest developments in natural color photography. A careful choice of the best methods has been selected for our readers; if interested in photography in colors you will find this book very useful.

**Bound in paper covers, 25c;  
in cloth 50c.**

Above Books may be had from all dealers or postpaid, from

**American Photographic Publishing Company**  
300 POPE BLDG. BOSTON, MASSACHUSETTS

# THE MAGAZINE For The PHOTOGRAPHER

## AMERICAN PHOTOGRAPHY

*Representing All That Its Name Implies*

**T**HIS practical and beautiful magazine covers every field of photographic activity in an adequate manner. All classes of workers will find something particularly adapted to their needs in every issue. It offers helpful articles, fine pictures, common sense editorials. Through its departments it gives direct help in every problem.

Picture criticism, shop notes, and the answering of questions, are facilities offered every reader.

"The Market Place" lists firms which buy photographs, with details as to their requirements and the prices paid, and gives other information as to how to make money with the camera.

The Monthly Prize Competitions offer incentive to improve your work. Prizes of \$10.00, \$5.00 and \$3.00 for advanced workers and \$5.00 and \$2.00 for beginners are awarded each month.

Single Copies..... 15 Cents  
Yearly Subscription..... \$1.50

## Chemistry for Photographers

By WILLIAM R. FLINT, Ph.D.

The part played by chemistry in photography is so important that a knowledge of photographic chemistry is a big help to the photographer. One does not need to be a chemist to understand the valuable material the author has placed in this book. It explains the types of chemical actions that have to do with photography, makes clear the application of each to some photographic process, and gives the reader such a clear idea of what he is doing chemically, while he works photographically, that he cannot fail to make systematic progress.

**Bound in cloth, \$2.00**

Special offer: CHEMISTRY FOR PHOTOGRAPHERS and one year's subscription to American Photography, \$2.75.

## Pictorial Landscape Photography

By JOHN A. HODGES, F.R.P.S.

Have you made the most of the landscape pictures in your collection? Here is a useful book that gives the principles of landscape photography in a nutshell. The chances are that after reading it you can study your pictures and make them more artistic by selective treatment. The illustrations will give you some standard by which you can judge your own efforts to see where they can be improved. The volume is sufficiently small to be carried in your coat pocket—it is the same size as our Practical Photography series—and can be conveniently taken with you when you go afield after landscape studies. Originally, this excellent book sold for 75c.

**Bound in paper covers, 25c.**

**American Photographic Publishing Company**  
300 POPE BUILDING BOSTON, MASS.

*The Perfect Combination for  
Superior Pictures*

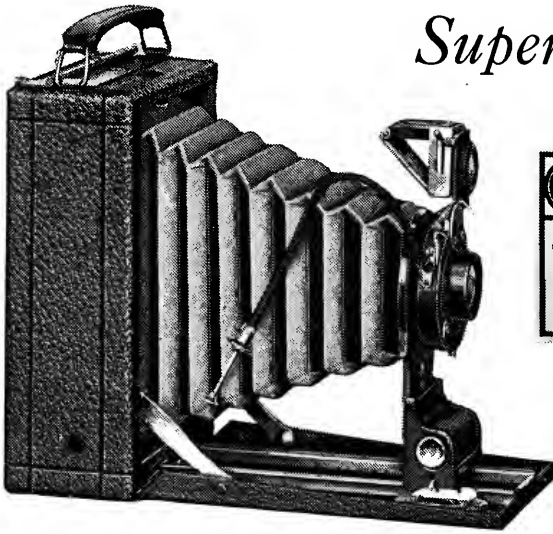

The **PREMO** and  
**PREMO FILM PACK**

*The Camera.* Premos are made upon such a simple principle that every operation, from loading to changing the films, can be performed almost instantaneously—much more easily and quickly than with any other type of camera. Premos are light and compact beyond all cameras for the same size pictures. Premos are so carefully equipped and tested as to assure the highest quality of results in the field for which each camera is designed.

*The Premo Film Pack.* The Premo Film Pack loads in daylight. To the pack is largely due the simple operation of the Premo cameras. It is the only film method which permits the removal of one or more films for development at any time. It offers the advantage of tank development, and being made from the same stock as Eastman N. C. film, its quality is the very highest possible.

The Premo catalogue has lots of interesting photographic information for you. The dealer will gladly supply you with a copy free, or we will mail it to you direct on request.

**ROCHESTER OPTICAL DIVISION**

EASTMAN KODAK CO.

ROCHESTER, N. Y.

For out-of-the-ordinary work

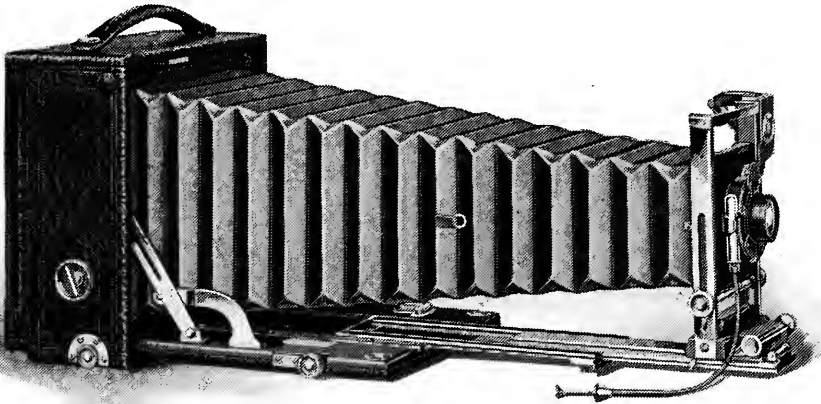

## *Premo No. 10*

Copying, enlarging, telephoto work, portraiture without the need of portrait attachments, architectural and wide angle lens photography are provided for in the long bellows draw, drop bed and swing back construction.

The ground glass offers the advantage of that sharp focusing and accurate composition which such work requires. The camera takes films or plates with equal facility, and while designed to cover the most special requirements in amateur photography, is yet so convenient, so simple and so comparatively light and compact that it is easily used as a "snap shot" camera for ordinary amateur photography.

Makes 5x7 pictures. Regularly furnished with Kodak Automatic shutter, Rapid Rectilinear lens, carrying case and one plate holder, for \$60.00. Is also listed with various anastigmat lens equipments.

Described in the Premo catalogue, a copy of which can be had for the asking from your dealer or from us direct.

ROCHESTER OPTICAL DIVISION

EASTMAN KODAK CO.

ROCHESTER, N. Y.

# THE ROYAL FOREGROUND GRADED FILTER



(Patented April 14th, 1911)

## STYLE A.

### The Latest and Greatest Improvement in Ray Filters

The only Ray Screen ever invented that will give an even, equal exposure to both sky and foreground, and produce a perfect cloud effect instantaneously with ordinary plates.

The Royal Foreground Ray Screen is so constructed that the color, which is a strong orange yellow at the top, is gradually diminished until perfect transparency is attained at the bottom. The practical effect of the gradual blending of color is to sift out or absorb the powerful chemical rays from the clouds and sky, which pass through the strongly colored top of the filter, without perceptibly decreasing the weak illumination of the reflected light from the foreground, which comes through the transparent or colorless lower part of the screen in full intensity.

The reason that daylight cloud pictures are rare is that the strength of the illumination from the sky is many, many times that of the partially absorbed and reflected light from objects on the ground.

If a correct exposure is given to the clouds, then the landscape is badly under-exposed; if the correct exposure is given to the landscape, then the clouds are literally burnt up from over-exposure, and no matter how contrasty they may have appeared to the eye, an unscreened photograph shows only a blank white sky.

The Royal Foreground Ray Screen is also very useful for subjects which are more strongly illuminated on one side than on the other, as in photographing by the light of a side window or in a narrow street. By simply turning the dark side of the foreground screen toward the bright side of the object a good, even exposure will result.

No.	Dia.	Ins.	Price	No.	Dia.	Ins.	Price
0A		$\frac{7}{8}$	\$1.35 Postpaid	8A		$2\frac{1}{2}$	\$2.70 Postpaid
1A	1	$\frac{5}{16}$	1.35	9A		$2\frac{3}{4}$	2.90
2A	for box cam.		1.35	10A		3	3.15
3A	1	$\frac{7}{16}$	1.35	11A		$3\frac{1}{4}$	3.60
4A		$1\frac{1}{2}$	1.35	12A		$3\frac{1}{2}$	4.05
5A		$1\frac{3}{4}$	1.80	13A		4	4.70
6A		2	2.00	14A		$4\frac{1}{2}$	5.40
7A		$2\frac{1}{4}$	2.25				

STYLE  
A

**GEORGE MURPHY, Inc.,** Retail Department

57 East Ninth Street

NEW YORK

*Send for booklet of all kinds of Supplementary Lenses*



# The Race for Lens Supremacy

*Demands True Quality*



FOR TWENTY-FIVE YEARS

# GOERZ LENSES

HAVE LED THE RACE

The famous GOERZ DAGOR F:6.8-F:7.7 needs no introduction. This lens has maintained its reputation of being the best all-around anastigmat ever produced. The well-known GOERZ CELOR F:4.5-F:5.5 has long held an enviable position as a fine high speed, studio group and general utility lens. For kodaks and other hand cameras the GOERZ SYNTOR F:6.8 meets efficiently the demand for a GOERZ LENS at a moderate price. There are other GOERZ LENSES adapted to every photographic requirement. There are also GOERZ CAMERAS, all equipped with GOERZ LENSES. The name GOERZ on any lens, camera or scientific instrument stands for QUALITY. This fact is worth your consideration. Call at your dealer's or write us direct.

**C.P. GOERZ AMERICAN OPTICAL COMPANY**  
317K East 34th Street, New York City

# Make Your Prints in Colors (40 Shades)

An Explanatory Diagram Showing the Various Stages in the Production of

## AUTOTYPE CARBON PHOTOGRAPHS

The Production of an Autotype Carbon Photograph  
HOW IT IS DONE

**A**  
The Coated Surface of Exposed Carbon Tissue (Pigmented Gelatine).

**B**  
Single Transfer Paper.

**C**  
Soak A and B in cold water, bring coated surfaces together in contact and squeeze.

**D**  
Place the adherent tissue and transfer paper between blotting boards for a few minutes. Next immerse in warm water, until the colored gelatine begins to ooze out at the edges.

**E**  
Strip off the Tissue backing paper and throw it away.

**F**  
A dark mass of colored gelatine is left on the transfer paper. This remains in the warm water and the gelatine surface is sprinkled over until the picture gradually makes its appearance.

**G and H**  
Continue until completed.

**I**  
The picture is now placed in an alum bath (five per cent.) to harden the film and discharge the bichromate sensitizing salt. A rinse in cold water completes the operation.

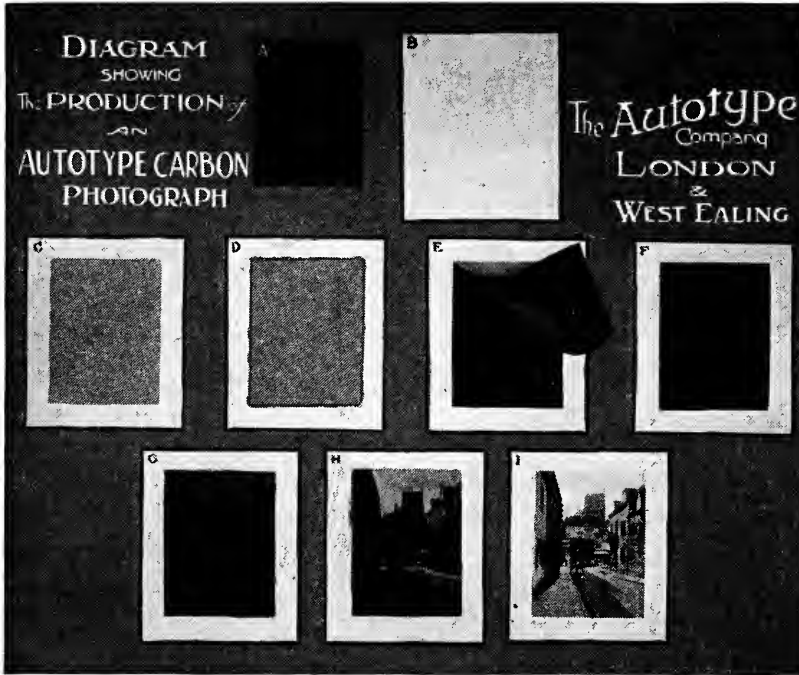

### TRIAL SETS OF CARBON PRINTING MATERIALS

In order to combat the erroneous notion, somewhat prevalent amongst Amateur Photographers, that a trial of the Carbon Process necessarily entails the expenditure of a considerable sum on costly apparatus, we have decided to introduce trial sets of the absolutely essential materials.

#### PRICES OF TRIAL SETS

No. 1 Outfit for 5 x 7.....	\$1.50	Postpaid
No. 2 Outfit Complete for 5 x 7.....	5.00	"
No. 4 Outfit Complete for 8 x 10.....	7.00	"

American Agents, GEORGE MURPHY, Inc., 57 East 9th St., New York

Send for Complete Booklet

# CALTONE DEVELOPER

## *The American Metol Substitute*

Has now been on the market for the past  
year and has met the most severe tests  
by critical users.

*Booklet on Request.*

**Berlin Aniline Works**

213 Water St., N. Y.

**Selling Agents**

# FUNNY PICTURES can be made with the DISTORTO

(Pat. Applied for)

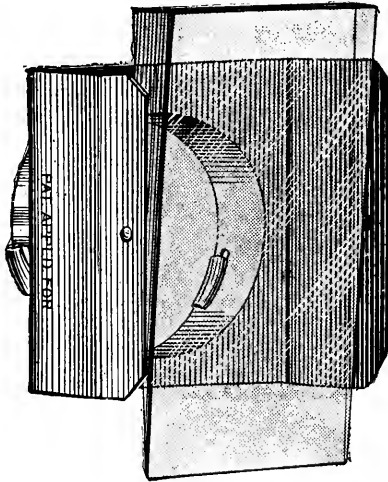

A new Optical instrument, used with any ordinary camera lens, which produces any degree of Distortion in the picture. Anyone may be photographed as Tall or Short, Fat or Thin, as a Grotesque Monstrosity or artistically beautified by means of the simple use of this wonderful instrument.

The Distorto produces effects in a photograph similar to those so often seen in distorting cylindrical mirrors. Instead of being fixed in one position and of one curvature, however, as mirrors must be, the Distorto, by means of a simple adjustment, may be set to produce anything from the slightest variation to the most absurd and ridiculous extremes.

No. 1 Fits Lens of 1	to 1 $\frac{5}{16}$ inch diameter	.....	\$1.35	Postpaid
" 2 " " " 1 $\frac{3}{8}$ "	1 $\frac{1}{2}$ " " "	.....	2.00	"
" 3 " " " 1 $\frac{1}{2}$ "	1 $\frac{3}{4}$ " " "	.....	2.70	"
" 4 " " " 1 $\frac{7}{8}$ "	2 " " "	.....	3.60	"

## ROYAL FOREGROUND GRADED SCREEN

Patented April 4th, 1911

### Style B (Universal)

An oblong ray filter graded from a deep yellow on one end to practically colorless glass on the other, mounted in a sliding frame so as to bring a filter of any desired depth of color in front of the camera lens.

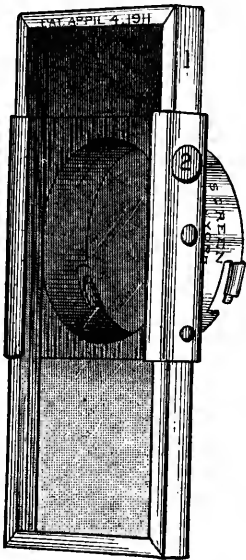

In the Style B Foreground we offer a ray filter for every conceivable orthochromatic purpose.

Maximum speed is attained for instantaneous exposures by means of the colorless or faintly tinted sections and maximum orthochromatism, or rendering of the true color values, by using the deeply colored portions with every possible gradation intervening.

It slips over the front of the lens the same as a lens cap, and may be instantly attached or removed. The Style B Foreground is the last word in Orthochromatics and its immense field of usefulness must commend it to every photographer desiring to obtain the best results in his art.

STYLE B		
No.	Dia. In.	Postpaid
1 B	1 $\frac{5}{16}$	\$2.70
3 B	1 $\frac{1}{8}$	2.70
4 B	1 $\frac{1}{2}$	2.70
5 B	1 $\frac{3}{4}$	3.60
6 B	2	4.05
7 B	2 $\frac{1}{4}$	4.50
8 B	2 $\frac{1}{2}$	5.40
9 B	2 $\frac{3}{4}$	5.85
10 B	3	6.30
11 B	3 $\frac{1}{4}$	7.20
12 B	3 $\frac{1}{2}$	8.10
13 B	4	9.45
14 B	4 $\frac{1}{2}$	10.80

**GEORGE MURPHY, Inc., Retail Dept., 57 E. 9th St., New York**





CYKO - LINEN WHITE



BINGHAMTON, N. Y.

11  
1A55  
1917

# The American Annual of Photography 1917

VOLUME XXXI

Edited by Percy Y. Howe



NEW YORK

THE AMERICAN ANNUAL OF PHOTOGRAPHY, INC.

MCMXVI

[TRADE MARK REGISTERED]

Copyright, 1916, by  
THE AMERICAN ANNUAL OF PHOTOGRAPHY, INC.,  
New York.



## P R E F A C E



URING the year 1916 there has been a marked increase in the amount of photographic goods manufactured in America, especially in the chemical line, so that we are now practically independent of the rest of the world for photographic materials. This result has been very largely brought about by the conflict still raging abroad. We earnestly hope that before our next volume is issued the entire world will be at peace again.

As usual, space has not permitted of our including all of the contributions, pictorial and literary. We extend our sincere thanks to all who have helped in any way in the making of this book.

Contributions for our next volume should reach us before August 10th, 1917, and should be forwarded to the address given below.

Percy Y. Howe, Editor.  
422 Park Hill Ave., Yonkers, N. Y.

# TABLE OF CONTENTS

## Contributed Articles

	PAGE
Titling Negatives. By G. T. Harris.....	9
Photographing Marine Subjects. By William S. Davis..... <i>Illustrated</i>	18
On Mastering The Anastigmat Lens. By A. H. Beardsley.....	23
Pinhole Photography. By J. A. Ernest Zimmermann..... <i>Illustrated</i>	29
Night Photography. By Arthur C. Brooks..... <i>Illustrated</i>	38
Gum-Platinum. By Guy Spencer..... <i>Illustrated</i>	46
The Photographic Portraiture Of Men. By T. W. Kilmer..... <i>Illustrated</i>	51
Color-Photography. By Wayne Morris.....	55
Sunset Photography. By A. Brooker Klough..... <i>Illustrated</i>	58
Practical Points On The Vest Pocket Camera. By A. W. H. Weston... <i>Illustrated</i>	64
Studio Coupons—What Shall We Do With Them? By Jessie Robinson Bisbee.	70
Some Cinematograph Hints. By A. Lockett..... <i>Illustrated</i>	78
Halation Corrected In Development. By George D. Jopson..... <i>Illustrated</i>	92
Exposure Meters. By J. W. Early.....	96
River Scenery—"Capturing" Running Water. By William H. Findlay. <i>Illustrated</i>	100
A Few Words About Autochroms. By David J. Sheahan.....	104
Photographing Flowers In The Fields. By Stillman Taylor..... <i>Illustrated</i>	107
A Simple Means of Producing Plate Marks on Mounts. By James N. Doolittle	110
Home Portraiture With Nitrogen Mazda Lamp And Reflector. By W. W. Morey..... <i>Illustrated</i>	114
The Selection of a New Camera. By Bayard Breese Snowden..... <i>Illustrated</i>	118
An Adjustable Copying Stand. By Henry F. Raess..... <i>Illustrated</i>	122
Laboratory Notes. By Marcus G. Lovelace.....	126
Water Panorams. By C. H. Claudy..... <i>Illustrated</i>	142
A Portable And Practical Lens Shade. By John Boyd..... <i>Illustrated</i>	150
A Convenient Dark-Room. By C. E. Owen..... <i>Illustrated</i>	154
Photographing The Sun. By William Henry..... <i>Illustrated</i>	158
The Focalplane Shutter And Its Aggressors. By A. L. Gareis..... <i>Illustrated</i>	162
Technical and Artistic Butterfly Photography. By Dr. R. W. Shufeldt. <i>Illustrated</i>	170
A Phantasy About Color-Photography And Colors. By John Lewisohn.....	182
Pictorial Sepia Prints On Japanese Tissue. By G. Arthur Tuttle..... <i>Illustrated</i>	188
The Land Of Make Believe. By J. A. Anderson..... <i>Illustrated</i>	192
Color-Toning Bromides. By A. T. Lakin, M.D..... <i>Illustrated</i>	196
A Plea For The Use Of Better Printing Mediums. By Luke R. Vickers.....	200
Picturesque New York. By William H. Zerbe..... <i>Illustrated</i>	202
Night Photography With The Soft Focus Lens. By Dr. W. G. Adams. <i>Illustrated</i>	208
The Needlehole in Architectural Photography. By A. M. Sutton..... <i>Illustrated</i>	214
Photographing Waterfalls. By Harry G. Phister..... <i>Illustrated</i>	226
Stereoscopic Photography. By E. J. Wall, F.R.P.S..... <i>Illustrated</i>	230
Amidol Developer. By Edward J. Davison.....	240
Oil And Bromoil For Portraiture. By Paul L. Anderson.....	244
A Plea For Pinhole Photography. By J. E. Adnams..... <i>Illustrated</i>	250
Gallery Lighting. By Sigismund Blumann.....	255
Border Frames For Photographs. By W. J. Curzon..... <i>Illustrated</i>	258
Baby's Best Biographer. By Roy Harrison Danforth.....	262
American Annual Formulary.....	273
United States Weights And Measures.....	282
English Weights And Measures.....	283
Metric System Of Weights And Measures.....	284
Conversion Of Metric Into English Measure.....	285
Chemical Elements; Their Names And Symbols.....	286
Table Of Comparative Plate Speed Numbers.....	286
Table Of Solubilities.....	287
Uniform System Numbers For Stops.....	288
The Reflecting Power Of Various Surfaces.....	289
Strength Of Various Lights.....	289
Table For Calculating Distances In Enlarging And Reducing.....	290
Table Of Distances For Use In Focusing.....	291
Length Of Studio Required For Different Lenses.....	291
American Photographic Societies.....	292

## Index to Subjects

	PAGE		PAGE
Adhesive for Labels.....	279	Landscape Photography,	
Adurol .....	273, 275	29, 58, 100, 107, 132, 142,	202
Amidol Formula.....	240, 273	Lantern Slides.....	136, 137, 275, 278
Anastigmat Lenses .....	23	Length of Studio.....	291
Architectural Photography.....	214	Lenses .....	23, 208
Autochrome.....	55, 104, 137, 279	Lenses, Cleaning.....	280
Babies, Photographing.....	262	Lens Shade.....	150
Blackening for Brass.....	280	Lighting .....	255
Blackening for Wood.....	280	Light, Strength of.....	289
Blue Print Paper.....	276	Marine Subjects .....	18
Border Frames .....	258	Metol Formula.....	274, 275
Bromides, Color Toning.....	196	Metric System.....	284
Bromide Paper .....	277	Miniature Cameras .....	64
Bromoil .....	244	Moonlight Pictures .....	280
Butterfly Photography .....	170	Motion Pictures .....	78
Cameras .....	64, 118	Mounting .....	110, 280
Camera Clubs.....	292	Negative, Titling .....	9
Carbon Printing.....	200, 278	Night Photography .....	38, 208
Cinematography .....	78	Nitrogen Mazda Lamps.....	114
Cleaning Bottles.....	280	Non-Abrasion Soda Mixture.....	281
Clouds in Lantern Slides.....	136	Oil Prints.....	244
Color in Lantern Slides.....	137	Ortol Formula .....	275
Color Photography.....	55, 104, 182	Paget Plate .....	55
Conversion of Metric System.....	285	Para-Amidophenol .....	129
Copying Stand.....	122	Pinhole Photography.....	29, 214, 250
Coupons .....	70	Plate Marks .....	110
Daguerreotypes .....	281	Plate Speeds .....	286
Dark-Room .....	154	Platinum Paper .....	278
Developers.....	126, 240, 273	Platinum Printing .....	200
Development .....	92	Poison and Antidotes.....	281
Doll Photography.....	192	Polished Surfaces .....	281
Duratol Formula.....	273	Portraiture.....	51, 114, 244, 262
Edinol Formula.....	273	Printing Mediums.....	200, 276
Eikonogen .....	274	Printing-out Papers.....	279
Elements, The .....	286	Pyrocatechin .....	129
English Weights .....	283	Pyro Formula .....	130, 274
Enlarging .....	290	Reduction .....	276, 290
Exposure .....	96	Reflecting Power of Various Sur- faces.....	289
Farmer's Reducer .....	276	River Scenery.....	100
Ferrous Oxalate .....	132	Rodinal Formula.....	275
Figures in Landscapes.....	132	Safe Lights .....	281
Film, To Remove.....	280	Salted Paper .....	278
Firelight Effects .....	280	Sepia Prints .....	188
Fixing Baths .....	275	Shutters .....	162
Flatten Prints .....	281	Sky in Landscapes.....	132
Flowers, Photographing .....	107	Societies, List of.....	292
Focalplane Shutters .....	162	Solubilities of Chemicals.....	287
Focusing Table of Distances.....	291	Stains, Removing.....	280, 281
Glycin Formula .....	274, 275	Stereoscopic Photography .....	230
Ground Glass Substitute.....	280	Strength of Various Lights.....	289
Ground Glass Varnish.....	280	Studio, Length of.....	291
Gum-Bichromate .....	278	Sun, Photographing .....	158
Gum Platinum .....	46	Sunset Photography .....	58
Gum Printing .....	200	Table of Distances.....	291
Halation .....	92	Tank Developers .....	275
Hardeners .....	275	Test for Hypo.....	281
Home Portraiture .....	114	Titling Negatives .....	9
Hydrochinon Formula.....	128, 273, 274, 275	U. S. Diaphragms.....	288
Hypo Test.....	281	U. S. Weights.....	282
Intensification .....	276	Water Panorams .....	142
Japanese Tissue.....	188	Waterfalls, Photographing .....	226
Kallitype .....	278	Weights and Measures,	282, 283, 284, 285
Lamps .....	114		

## Index to Authors

	PAGE		PAGE
Adams, Dr. W. G.	208	Klugh, A. Brooker	58
Adnams, J. E.	250	Lakin, A. T., M.D.	196
Anderson, J. A.	192	Lewisohn, John	182
Anderson, Paul L.	244	Lockett, A.	78
Beardsley, A. H.	23	Lovelace, Marcus G.	126
Bisbee, Jessie Robinson	70	Morey, W. W.	114
Blumann, Sigismund	255	Morris, Wayne	55
Boyd, John	150	Owen, C. E.	154
Brooks, Arthur C.	38	Phister, Harry G.	226
Claudy, C. H.	142	Raess, Henry F.	122
Curzon, W. J.	258	Sheahan, David J.	104
Danforth, Roy Harrison	262	Shufeldt, Dr. R. W., C.M.Z.S.	170
Davis, William S.	18	Snowden, Bayard Breese	118
Davison, Edward J.	240	Spencer, Guy	46
Doolittle, James N.	110	Sutton, Dr. A. M.	214
Early, J. W.	96	Taylor, Stillman	107
Findlay, William	100	Tuttle, G. Arthur	188
Gareis, A. L.	162	Vickers, Luke R.	200
Harris, G. T.	9	Wall, E. J., F.R.P.S.	230
Henry, William	158	Weston, A. W. H.	64
Jopson, George D.	92	Zerbe, William H.	202
Kilmer, T. W.	51	Zimmermann, J. A. Ernest	29

## Index to Illustrators

	PAGE		PAGE
Adams, W. G., M.D.	209, 211	Hill, F. W.	98
Adnams, J. E.	251	Hitchin, A. L.	60
Anderson, J. A.	192, 193	Hungerford, Blanche C.	15, 223
Beam, George L.	183	Hunt, P. S.	213
Bisbee, Clarence E.	71	Jackson, F.	165
Bostock, Cecil W.	22	James, T. L.	231
Boughton, Alice	27, 135, (Insert)	Jeffery, Haswell C.	57, 250
Boultenhouse, John E.	187	Johnson, Belle	(Inserts) 64, 136
Boyd, John	150, 152	Jopson, George D.	93, 95
Bridge, Rupert	(Insert)	Kattelmann, Carl H.	265
Brigman, Anne	83	Kilmer, T. W.	50, 52, 54
Brogden, T. F.	139	Kimberly, G. P.	243
Brooks, Arthur C.	39	Klugh, A. Brooker	58, 62
Brown, Fedora E. D.	207	Koehler, August G.	239
Brown, E. J.	212	Knaff & Bro.	(Insert) 9, 61
Carlyle, Thomas	(Insert) 85, 257	Laity, Warren R.	149
Cazneaux, Harold	(Insert) 160, 219	Lakin, A. T., M.D.	197
	(Insert) 288	Leppert, E. D.	13, 206
Claudy, C. H.	146, 148	Lerski, Helmar	241
Cohen, Edgar A.	(Insert) 120	Lockett, A.	80, 81, 82, 86, 89
Conkling, O. C.	75, 237	Ludlum, William Jr.	267
Cooke, Helen W.	67	Mackinnon, M.	215
Crandall, E. L.	63	McCall, Edward S.	194
Curzon, W. J.	258, 260, 261	McFarlin, A.	147
Daring, Arthur	247	Morey, W. W.	114, 115
Davis, Rae	37	Owen, C. E.	154, 155, 157
Davis, William S.	19, 21	Paton, James E.	199
Davison, Edward J.	240	Peterson, J. R.	59, 253
Doolittle, James N.	111, (Insert) 168	Phister, Harry G.	226, 227, 228
Doutt, Chas. W.	28, 90, 153	Poynter, W. B.	181
Duhrkoop, Rudolf	(Insert) 99, 123	Raess, Henry F.	122, 124, 125
Eickemeyer, Rudolf	(Inserts) 40, 96	Rice, William S.	190
Eitel, Theodore	(Inserts) 56, 224	Roy, L. M. A.	45
Ellis, William Shewell	(Insert) 88	Sawyer, W. C.	229
Emerick, S. P.	35, 221	Schwarz, Ira D.	(Insert) 256
Feldman Studio	245	Schweickert, P. J.	145, 254
Fleckenstein, Louis F.	91, 151	Seymour, George Steele	(Insert) 24
Findlay, William	101, 103	Sheahan, David J.	106
Gabriel, Herman	195	Shufeldt, Dr. R. W., C.M.Z.S.,	171, 173, 175, 177, 178, 179
Gareis, A. L.	162, 163, 168, 169	Simson, Claude H.	269
Gill & Son	238	Smith, Kate	(Inserts) 104, 184
Gillies, John Wallace	(Insert) 128	Snowden, Bayard Breese	119, 121
Graves, Nathan R.	(Insert) 17, 94, 180	Sornberger, Dr. F. F.	198
Harting, G. W.	(Insert) 72, 113, 117	Spencer, Guy	47, 49
Henry, William	158, 160, 161		

## Index to Illustrators—Continued

	PAGE		PAGE
Street, Albert B.....	131	Wakeford, C. E.....	127
Stump, H. Withrington... (Insert)	216	Warfield, M. S.....	263
Sutton, A. M., M.D.. 214, 216, 218,	220	Webb, Sidney V.....	143, 242
	225	Weston, A. W. H.....	66
Sweet, L. D.....	31	Weston, Edward Henry. 79, (Insert)	200
Taylor, Stillman.....	107, 108, 109	White, Edwin J.....	43
Tenkyukwai, The.....	235, 259	Whitehead, John M..... (Insert)	152
Thomas, Bessie W.....	87	Williar, Harry D.. 11, 69, (Insert)	248
Thompson, Maurice.....	68, 272		271
Tuttle, G. Arthur.....	189, 191	Willard, S. H.....	159
Volkman, O. K.....	112	Zerbe, William H.....	203, 205
Wall, E. J., F.R.P.S.....	233, 234, 236	Zimmerman, J. A. Ernest. 29, 30, 32,	33

## Index to Advertisers

	PAGE
American Photographic Publishing Co.....	viii, ix
AnSCO Company.....	i-iv
Berlin Aniline Works.....	xv
Brooklyn Chemical Laboratories.....	xxxv
Burke & James, Inc.....	Insert after xxxviii
Cohen, A.....	xxxvii
Cramer Dry Plate Co., G.....	xxxiii
Eastman Kodak Co.....	Fourth Cover; xvii-xxv
Gennert, G.....	xli-xliv
Goerz, C. P., American Optical Co.....	xiii
Guide To Nature, The.....	xxxvii
Hammer Dry Plate Co.....	xxxix
Harvey, G. L.....	xxxii
Herman & Herman, Inc.....	xxxix
Higgins & Co., C. M.....	xxxiv
Johnston, J. V.....	xxxv
Kathol Mfg. Co., Inc.....	xxxvi
Lewis, J. L.....	xxxiv
Meyer Camera & Instrument Co., Inc.....	xxxiv
Murphy, Inc., George... Second and Third Covers; vii, xii, xiv, xvi, xxviii, xxix,	xxxix
New York Camera Exchange.....	xxvii
Paasche Air Brush Co.....	xxxiii
Phototaker Co., The.....	xxxvi
Reflex Camera Co.....	xxxiv
Rochester Optical Co.....	x, xi
Rough & Caldwell Co.....	xxvi, xxx
Smith & Sons, J. H.....	xxxii
Standard Paper Co.....	Insert after xxxviii
Stern & Co., David.....	xxxviii
Sussex Photo Supply Co.....	xxxviii
Tennant & Ward.....	vi
Watson & Sons Limited, W.....	xl
Wolff & Dolan.....	xxxvi
Wollensak Optical Co.....	v

REFERENCE CALENDAR FOR THREE YEARS

1916

							1916																		
	S	M	T	W	T	F	S		S	M	T	W	T	F	S		S	M	T	W	T	F	S		
Jan.	..	..	..	..	..	..	1	May	..	1	2	3	4	5	6	Sept.	..	..	..	..	..	..	1	2	
	2	3	4	5	6	7	8		7	8	9	10	11	12	13		3	4	5	6	7	8	9		
	9	10	11	12	13	14	15		14	15	16	17	18	19	20		10	11	12	13	14	15	16		
	16	17	18	19	20	21	22		21	22	23	24	25	26	27		17	18	19	20	21	22	23		
	23	24	25	26	27	28	29		28	29	30	31	..	..	..		24	25	26	27	28	29	30		
Feb.	30	31	..	..	..	..	..	June	..	..	..	..	..	..	1	2	3	Oct.	1	2	3	4	5	6	7
	..	..	1	2	3	4	5		4	5	6	7	8	9	10	8	9		10	11	12	13	14		
	6	7	8	9	10	11	12		11	12	13	14	15	16	17	15	16		17	18	19	20	21		
	13	14	15	16	17	18	19		18	19	20	21	22	23	24	22	23		24	25	26	27	28		
	20	21	22	23	24	25	26		25	26	27	28	29	30	..	29	30		31	..	..	..	..	..	
Mar.	27	28	29	..	..	..	..	July	..	..	..	..	..	..	1	2	3	Nov.	..	..	..	1	2	3	4
	..	..	..	1	2	3	4		2	3	4	5	6	7	8	5	6		7	8	9	10	11		
	5	6	7	8	9	10	11		9	10	11	12	13	14	15	12	13		14	15	16	17	18		
	12	13	14	15	16	17	18		16	17	18	19	20	21	22	19	20		21	22	23	24	25		
	19	20	21	22	23	24	25		23	24	25	26	27	28	29	26	27		28	29	30	..	..		
April	26	27	28	29	30	31	..	Aug.	30	31	..	..	..	..	1	2	3	Dec.	..	..	..	..	..	1	2
	..	..	..	..	..	1	2		6	7	8	9	10	11	12	3	4		5	6	7	8	9		
	2	3	4	5	6	7	8		6	7	8	9	10	11	12	10	11		12	13	14	15	16		
	9	10	11	12	13	14	15		13	14	15	16	17	18	19	17	18		19	20	21	22	23		
	16	17	18	19	20	21	22		20	21	22	23	24	25	26	24	25		26	27	28	29	30		
23	24	25	26	27	28	29	27	28	29	30	31	..	..	31	..	..	..	..	..	..					
30	..	..	..	..	..	..	..	..	..	..	..	..	..	..	..	..	..	..	..	..					

1917

							1917																	
	S	M	T	W	T	F	S		S	M	T	W	T	F	S		S	M	T	W	T	F	S	
Jan.	..	1	2	3	4	5	6	May	..	..	1	2	3	4	5	Sept.	..	..	..	..	..	..	1	
	7	8	9	10	11	12	13		6	7	8	9	10	11	12		2	3	4	5	6	7	8	
	14	15	16	17	18	19	20		13	14	15	16	17	18	19		9	10	11	12	13	14	15	
	21	22	23	24	25	26	27		20	21	22	23	24	25	26		16	17	18	19	20	21	22	
	28	29	30	31	..	..	..		27	28	29	30	31	..	..		23	24	25	26	27	28	29	
Feb.	..	..	..	1	2	3	..	June	..	..	..	..	..	1	2	Oct.	30	..	..	..	..	..	..	
	4	5	6	7	8	9	10		3	4	5	6	7	8	7		8	9	10	11	12	13		
	11	12	13	14	15	16	17		10	11	12	13	14	15	16		8	9	10	11	12	13		
	18	19	20	21	22	23	24		17	18	19	20	21	22	23		14	15	16	17	18	19	20	
	25	26	27	28	..	..	..		24	25	26	27	28	29	30		21	22	23	24	25	26	27	
Mar.	..	..	..	1	2	3	..	July	1	2	3	4	5	6	7	Nov.	..	..	..	..	..	1	2	3
	4	5	6	7	8	9	10		8	9	10	11	12	13	14		4	5	6	7	8	9		
	11	12	13	14	15	16	17		15	16	17	18	19	20	21		15	16	17	18	19	20		
	18	19	20	21	22	23	24		22	23	24	25	26	27	28		11	12	13	14	15	16	17	
	25	26	27	28	29	30	31		29	30	31	..	..	..	..		18	19	20	21	22	23	24	
April	1	2	3	4	5	6	7	Aug.	..	..	..	1	2	3	4	Dec.	..	..	..	..	..	..	1	
	8	9	10	11	12	13	14		5	6	7	8	9	10	11		2	3	4	5	6	7	8	
	15	16	17	18	19	20	21		12	13	14	15	16	17	18		9	10	11	12	13	14	15	
	22	23	24	25	26	27	28		19	20	21	22	23	24	25		16	17	18	19	20	21	22	
	29	30	..	..	..	..	..		26	27	28	29	30	31	..		23	24	25	26	27	28	29	
..	..	..	..	..	..	..	..	..	..	..	..	..	..	..	..	..	..	..	..	..				

1918

							1918																
	S	M	T	W	T	F	S		S	M	T	W	T	F	S		S	M	T	W	T	F	S
Jan.	..	..	1	2	3	4	5	May	..	..	..	1	2	3	4	Sept.	1	2	3	4	5	6	7
	6	7	8	9	10	11	12		5	6	7	8	9	10	11		8	9	10	11	12	13	14
	13	14	15	16	17	18	19		12	13	14	15	16	17	18		15	16	17	18	19	20	21
	20	21	22	23	24	25	26		19	20	21	22	23	24	25		22	23	24	25	26	27	28
	27	28	29	30	31	..	..		26	27	28	29	30	31	..		29	30	..	..	..	..	..
Feb.	..	..	..	..	..	..	1	June	..	..	..	..	..	1	2	Oct.	..	..	1	2	3	4	5
	..	..	..	..	..	1	2		2	3	4	5	6	7	8		6	7	8	9	10	11	12
	3	4	5	6	7	8	9		9	10	11	12	13	14	15		13	14	15	16	17	18	19
	10	11	12	13	14	15	16		16	17	18	19	20	21	22		20	21	22	23	24	25	26
	17	18	19	20	21	22	23		23	24	25	26	27	28	29		27	28	29	30	31	..	..
Mar.	24	25	26	27	28	..	..	July	30	..	..	..	..	..	..	Nov.	..	..	..	..	..	1	2
	..	..	..	..	..	1	2		..	1	2	3	4	5	3		4	5	6	7	8	9	
	3	4	5	6	7	8	9		7	8	9	10	11	12	13		10	11	12	13	14	15	16
	10	11	12	13	14	15	16		14	15	16	17	18	19	20		17	18	19	20	21	22	23
	17	18	19	20	21	22	23		21	22	23	24	25	26	27		24	25	26	27	28	29	30
April	24	25	26	27	28	29	30	Aug.	28	29	30	31	..	..	Dec.	1	2	3	4	5	6	7	
	31	..	..	..	..	..	..		..	..	1	2	3	4		8	9	10	11	12	13	14	
	..	1	2	3	4	5	6		4	5	6	7	8	9		10	15	16	17	18	19	20	21
	7	8	9	10	11	12	13		11	12	13	14	15	16		17	22	23	24	25	26	27	28
	14	15	16	17	18	19	20		18	19	20	21	22	23		24	29	30	31	..	..	..	..
21	22	23	24	25	26	27	25	26	27	28	29	30	31	..	..	..	..	..	..				
28	29	30	..	..	..	..	..	..	..	..	..	..	..	..	..	..	..	..	..				

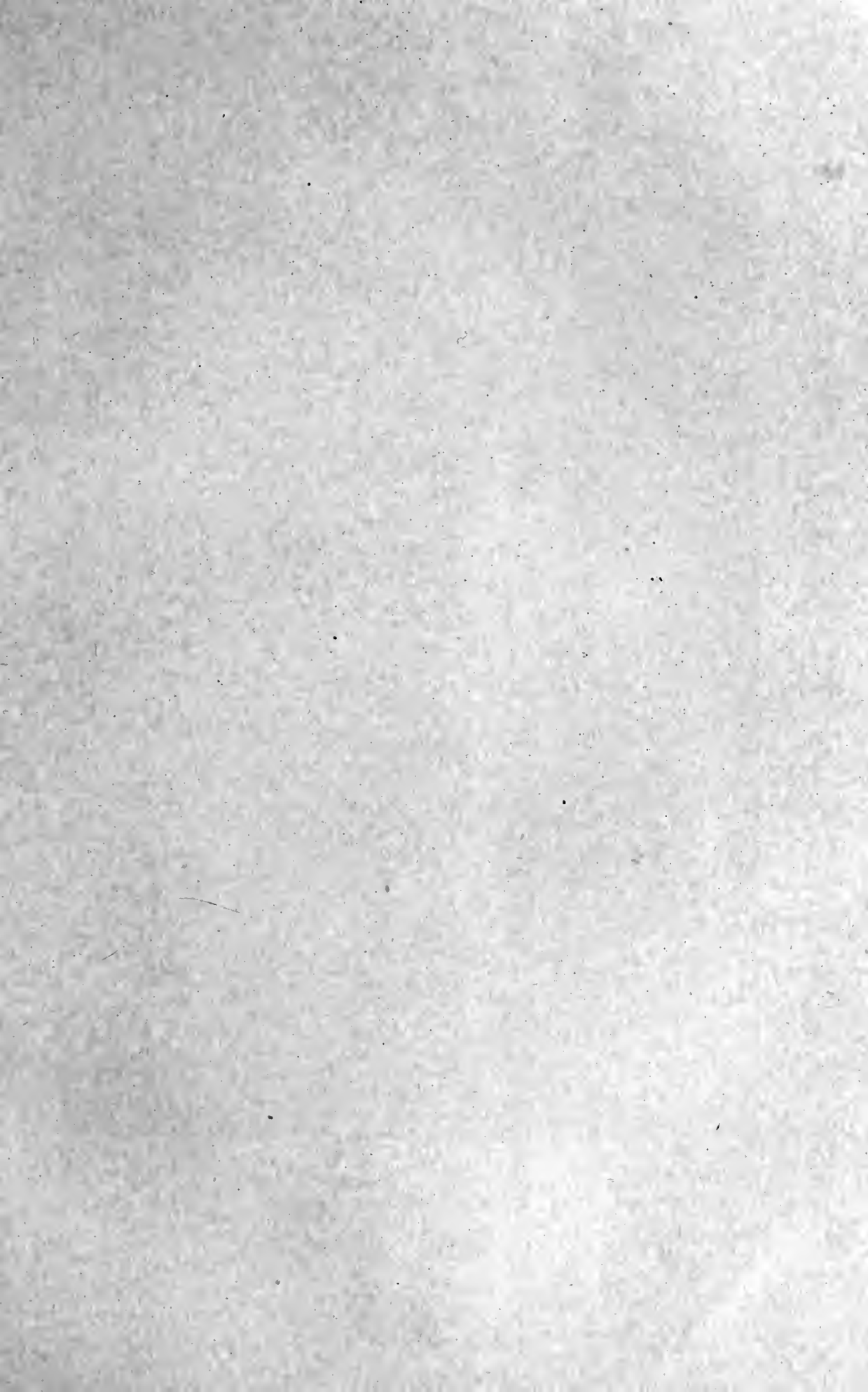



PORTRAIT.

Knaff & Bro.



# The American Annual of Photography · · 1917

---

## TITLING NEGATIVES

By G. T. HARRIS

**T**ITLED negatives are seldom wanted outside a publishing business; to the publisher, however, they are a prime necessity. A concise title, neatly and legibly printed is greatly appreciated by the public who purchase mementoes of their holiday trips; it is also of great importance in facilitating re-ordering, both by the selling agent and by the purchaser. How often does the publisher receive from some unknown person an inquiry "I have a view of your number 13977 Dartmoor, Kistvaen, at Metherall, kindly say if you can supply me with six copies, and the price"; or one on similar lines! Once a view leaves the shop-keeper it becomes a potential advertisement for its producer, who should make it easy for the buyer to satiate himself or his friends with it.

Many ways exist of titling negatives, some of extreme untidiness and clumsiness; some with typography too large for the size of the print, others with it too small. It seldom strikes one as being an integral part of the negative, that is, it so often gives one the idea of being added perfunctorily, as an operation demanding no care or thought, and merely one to be hurried over as quickly as possible. The old school of view publishers for some time set their faces against inscribing the title on the negative, holding that its presence on the print was inartistic and vulgarized it. Such esoteric notions, however, had to give way to public clamour and after trying various devices for obviating its appearance actually on the view itself

(a plain margin bearing it, etc.) they finally accepted the inevitable. But, like all their work, when it was done it was well done, and only those who served their apprenticeship to them know the time and trouble expended in titling a series of negatives. With the coming of the post-card came the lowered standard of work all round, and titling in the hands of untrained view publishers became a perfect nightmare. Even portrait photographers of standing when they made excursions into view publishing, as many did, and produced their own photographic cards regarded the title as a mere act of super-erogation. Mechanically printed cards like half-tone and colotype were largely exempt from criticism, as the one had the title in good clean type and the other had it written by an accomplished lithographic writer.

Coming now to the actual production of the title. If a series of views has to be titled it should be accepted that the work is of equal importance with any operation in the production of the negative, exposure, development or retouching, and the necessary time and care should not be begrudged. It is obvious that in cases where a negative is of temporary utility only the titling may be accomplished by some means involving the least time and trouble. The one usually adopted in such cases is curiously enough the very one demanding most experience, that is, writing the title reversed direct on to the negative. Only prolonged experience will enable any one to do this quickly and neatly. The quickest and neatest way of titling a negative temporarily, or for a few copies, is to take a sheet of very clear and thin gelatine, write the title on it with a pen and opaque ink in script and when dry mount it face down on the film of the negative, affixing it with a solution of gum arabic or thin Canada balsam. The script may, and does, look amateurish, but it is at least neat. Of course Roman characters may be used if the writer considers himself accomplished in their production. Reversed rubber type takes longer because of the setting up required, but is very much more workmanlike, care being had that its size is proportioned to that of the print.

Another method of titling small quantities of negatives, and one that has been frequently used and often recommended is to invoke the aid of a professional typographer by having the



HARRY D. WILLIAR.

titles required set up and printed on a sheet of paper. This is photographed on a very clean and slow mechanical plate, the film is stripped and the titles cut up and mounted on the negatives. The result when the work has been carefully done is excellent, and it is obvious that the same sheet of printed titles may serve for several sizes of negatives by the approximation of the photographic reproduction. One drawback to this particular method rather discounts its usefulness in England, which is that printers usually charge for setting up the sheet of titles, and the charge seems out of all proportion to the amount of work supplied. Probably this objection might not apply in America.

My own method which I worked out years ago and have had constantly in use is based on the possession of a small typographic press. This need not be an elaborate affair, one printing a sheet about crown 8vo is sufficiently large, but it may be desirable to supplement the amount of type usually supplied with model presses by purchasing an extra quantity, otherwise a run on some particular letter (and this constantly happens) may find the form hung up short of completion. Sheets of very thin, clear and hard gelatine are also required upon which to print off, and this really is the principal drawback to the process. These sheets of gelatine are seldom to be got even from those who claim to deal in such material. In London I quite failed to get suitable sheets from any gelatine dealers I knew of and was compelled eventually to make them for myself. This I did by coating 10 x 12 plates with hard emulsion gelatine, having first carefully cleaned and polished the plate with French chalk. The coated plates were "set" on a leveled slab and dried in the plate drying room. When cut through near the edge of the plate the film stripped readily enough. However, if these films can be bought some trouble will be saved.

Let me assure the uninitiated who may be inclined to repudiate this method of titling without a trial on account of its printing press, that the gentle calling of compositor is by no means so difficult of accomplishment as it looks to an outsider. That is to say, the amount of setting up an 8vo sheet of titles takes is well within the capacity of any photographer who can use his fingers, and after the first couple of days' apprentice-



THE WHITE SILENCE.

E. D. LEPPERT.

ship matters move if not expeditiously at least smoothly. The first requirement in preparing to title a series of negatives is a careful list of the titles with the number of negative connected with each title, thus 13670. *Chagford. The Longstone and Kestor*. Choosing the exact title requires some care, at least in England, where practically every acre of ground is named, and often has historical or antiquarian interest, perhaps both, associated with it. Further, it should be remembered that the view buying public are not all the hilarious char-à-bancers who generously and thoughtlessly distribute broken bottles and scraps of paper in places where they have erected their holiday Bethel. Quite a large proportion of those who buy views have discrimination and taste and purchase in accordance as these are satisfied.

To loosely and inaccurately title some view is to lower its value in such people's estimation and may cause them to pass it over. Hence whatever literary, historical or antiquarian interest may be represented in a view should be considered in deciding on a title, and if possible incorporated with it. It is always desirable to localize a view as much as possible when it possesses no unique or distinguishing feature. For instance, "*River Teign on Dartmoor*" is certainly a correct title for the view I have in mind, but it may be anywhere in a radius of twelve miles. "*Dartmoor. The North Teign River at Gidleigh*" instantly localizes it, separates it from the branch known as the South Teign and indicates a favourite spot on the moor. Always regard the title as the finishing touch and bestow as much care on its accuracy and composition as was bestowed on the choice and composition of the view.

Following the number of the negative is usually placed the name of the district, which groups all views and prevents confusion in dealing with them, it also carries considerable weight when dealing with the local selling agent. "*Queen's Bower, New Forest*," is quite accurate and sufficient, but "*Brockenhurt, Queen's Bower*," gets one an order from the local stationer much easier. "It hits him where he lives," as you say in America.

So, with deliberation and care you compile your list of titles, a number and title to a line until your 8vo sheet is full. Proofs are pulled on paper until the pressure is seen to be



WEEDS.

BLANCHE C. HUNGERFORD.

evenly distributed, corrections are duly made, and the printing on to the gelatine sheets may then take place. A good stiff ink and moderately soft roller should be used for inking up the type and the pressure should be such as will just give a good imprint and no more. On removing the gelatine sheet the letterpress should appear in clean cut, well-filled letters, no smudging or cutting of the gelatine sheet due to over-pressure. The requisite number of sheets having been printed and laid out upon a clean table are now to have the letters re-inforced by dusting upon them finely powdered electrotyper's plumbago. To do this take each gelatine sheet, lay it upon a clean piece of paper, shake upon it a small quantity of the plumbago, then with a tuft of cotton wool or soft camel hair mop dust it about the letterpress to which it will adhere. The surplus plumbago is dusted off the sheet, which is then laid aside until the ink is well hardened, which occupies perhaps a couple of days.

To use the printed titles the sheets are cut up by using a keen knife and steel straight edge, trimming each title so that as little as possible remains of the gelatine around the lettering. When printed from the negative should show a print bearing the number and title parallel with the base line in the left hand corner, and about an eighth of an inch above the base line when trimmed. To affix the gelatine title to the negative place the negative upon a retouching desk film upwards, see that the portion of film where the title has to be placed is of sufficient transparence to allow the opaque lettering to show while on a dark ground when printed, then wet that portion of the film by brushing over it a weak solution of gum arabic. With a pair of tweezers carefully place the gelatine title, letterpress in contact with the film, down on the dampened spot, seeing that no air bells occur. The thin gelatine title may buckle a little at first, but will gradually straighten as the moisture evaporates, and when dry will be perfectly adhesive to the negative film all over its surface. When the titles are dry they should be inspected to see if any filling up or sharpening of letters is required with opaque colour, or periods and commas added, after which the negative is ready for varnishing. If the gelatine film was clear and thin the title will show as plain white letterpress without any indication whatever of



its support, but any appreciable thickness in the title film will be sure to show as a white line surrounding the title. I have used tough collodion films as a printing sheet, and as regards transparency and thinness they are ideal, but the manipulation of them is an operation requiring so much care that I hesitate to recommend their use.

It will of course be readily understood that no one would adopt this method of titling negatives who has only an odd one or two at intervals to deal with, for such the method of writing the title in script upon gelatine strips is quite sufficient. But for the view publisher who deals with series of negatives, who catalogues subjects by the hundred and whose prints from popular view negatives run into thousands something more elaborate and workmanlike is necessary. In such a business one has only to let a few untitled and unnumbered negatives creep into a series to know what satisfaction and comfort come from a properly titled negative. Further, when once the titles are set up it is the easiest thing in the world to print off fifty or so copies of the set, and these are invaluable for sending out to local agents for reference, or to post to a visitor's inquiry for further views of a certain district. When facility with the printing press has been attained not only titles but many odds and ends of printing find their way from it that otherwise would be paid for at proof rate or replaced by untidy script.



VERIS SUPERBA.

NATHAN R. GRAVES.

## PHOTOGRAPHING MARINE SUBJECTS

By WILLIAM S. DAVIS



WHEN one's vacation is spent at the seashore the chances of obtaining interesting snapshots are many, but, as working conditions on or near the water vary considerably from those found inland, a few words of advice may save the inexperienced from making preventable mistakes, with their accompanying disappointments.

In the first place, don't let your camera lie around in the bright sunshine when not in use, for aside from the possibility of intense light finding a minute place to penetrate, the heat is bad for the sensitive materials, and grit or sand may work into the shutter, thus affecting its operation. If a regular carrying-case is not used the camera can be protected with a focusing-cloth.

The supply of plates or films both before and after exposure should be kept in as dry and cool a place as possible, since a few weeks of moist heat is liable to injure the freshest material.

If one uses a folding camera of the usual variety it is well to protect the lens against the intense glare of reflected light coming from the water, or open beach, by making a short tube (say about three-quarters to one inch long according to size of lens) which will just fit around the front lens cell. Many a seashore negative has turned out flat and foggy because of strong reflected light shining into the lens.

As the noonday sun in summer is high few shadows are cast, the entire scene being generally a mass of light tones, so more artistic effects are, as a rule, obtained by exposing in the morning or afternoon, when longer shadows are cast and the gradation of tone is softer. Under such conditions one can see the brilliant sparkle in the high lights and pleasing detail and texture on the rocks, or shore, if the light comes either from one side or toward the camera.

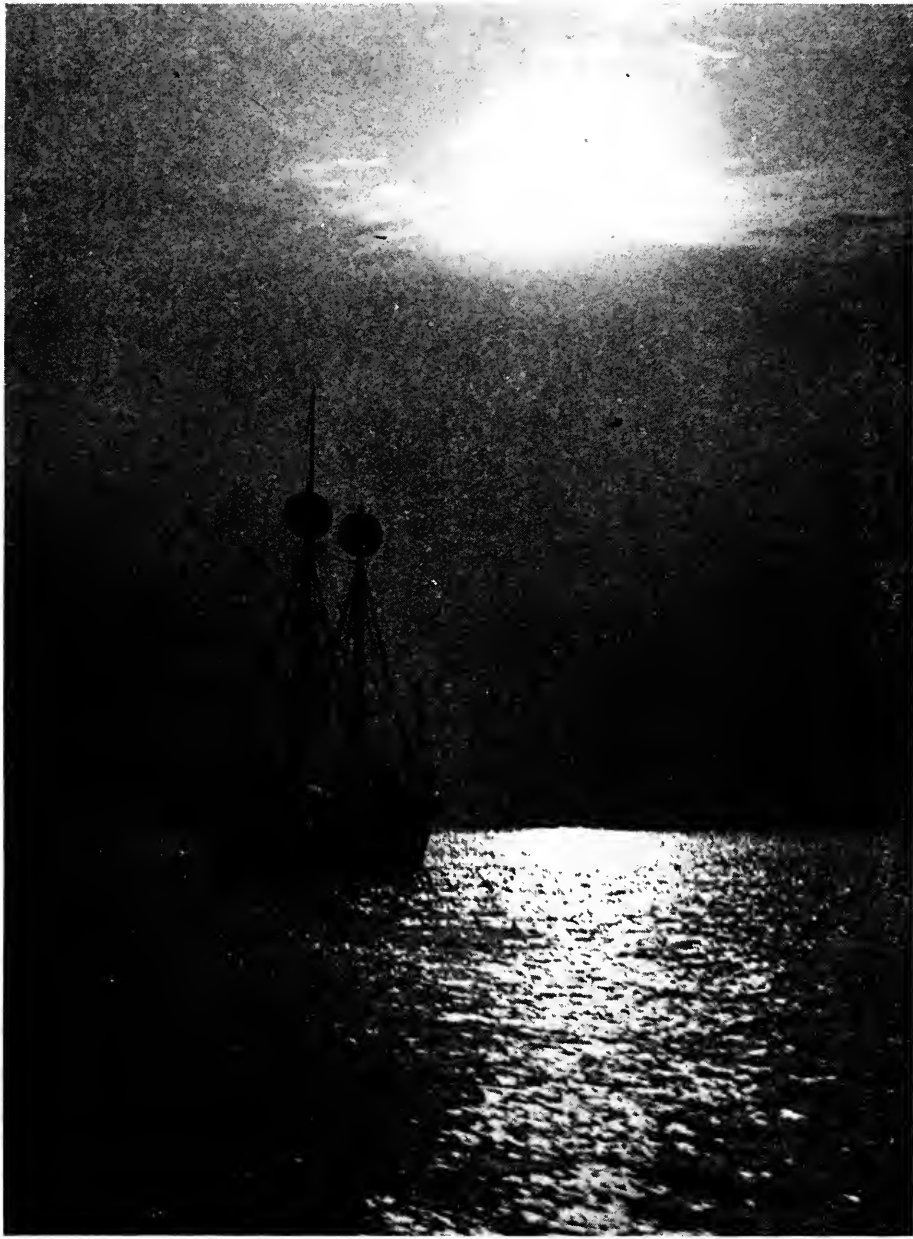

THE LIGHTSHIP.

WILLIAM S. DAVIS.

A clear day is by no means essential for good results, even with a cheap outfit, for the light is usually strong enough to allow of snapshotting open scenes, and some of the most beautiful subjects are seen in a morning fog, or under the mellow sunshine and clouds of late afternoon; while if one is fortunate enough to be on the coast during a gale the opportunity of taking the inrushing combers and flying spray is not to be missed.

The great thing to aim for in taking surf is to have a background of water or sky dark enough to contrast with the flying foam, since a blank white sky in the picture will quite spoil the effectiveness of the result. Low lying banks of grey cloud, or the dark steely-blue tone which the sky sometimes assumes, make the best background, especially when a glint of sunshine lights up the waves. When the speed of one's shutter is adjustable it should be set at  $1/25$  second for surf, as this will best render the motion of the water.

Working in good light during the middle of the morning or afternoon the medium sized lens stop of an ordinary camera should be used, or No. 16 on a marked diaphragm scale. In making the exposure hold the camera firmly against the body, with feet braced against the wind—then watch until a big wave is headed for shore, and snap the shutter as it breaks. If you wait until the spray is seen to rise to the full height the chances are against catching the maximum effect on the film, because of the fraction of time which must elapse before the shutter can operate.

Beaches in pleasant weather, and the waterfront of picturesque ports, offer attractive subjects, with or without figures, but if people are included see that they fit in with the scene and don't stop their work to stare at the camera.

Vessels, both in port and under sail, are nearly always pleasing. When taken from shore it is possible to give quite a slow shutter exposure without danger of blurring, but if one is on a moving boat it is safer to use a speed of  $1/50$  to  $1/100$  second, on account of the double motion of subject and camera. In good light, and shutter set for these speeds, a rather small lens stop (No. 16 or 32) is correct for shipping in the open between 9 a. m. and 3 p. m., but in early morning, or when



WILLIAM S. DAVIS.

WHEN THE SURGES ROAR.

taking sunsets over the water, the largest stop of an ordinary lens will not admit too much light.

Owing to the amount of reflected light found at the seashore, it may be stated as a general guide that average subjects found along shore need only half the exposure of an open landscape inland, while views taken afloat may be given one-quarter the time.

When developing, keep the negatives moderately thin, so as to preserve the delicate detail and gradation of tone in sky and water, which contribute so much to the charm of a good marine picture.



FAST FALLS THE EVENTIDE.

CECIL W. BOSTOCK.

# ON MASTERING THE ANASTIGMAT LENS

By A. H. BEARDSLEY



HERE is no short cut to success in life, nor to the mastery of the anastigmat lens. To be sure, there are some basic rules to follow even as there are in the pursuit of success; but, beyond these, success or failure depends upon the study and development of rudimentary facts by each individual.

One man uses F:8 because somebody says so; another uses F:8 because he knows exactly what relation this stop bears to his subject, exposure, focus, definition and depth of field. If both men stood side by side, both would probably obtain equally good negatives. However, suppose our first man finds himself under conditions not covered by what somebody says,—then what? Our second man, on the other hand, is merely confronted with different conditions to which he readily adapts himself because he knows *why* and not merely *how*.

It is not necessary that the purchaser of a new anastigmat should plunge into optics in order to know the *why* as well as the *how* of its successful manipulation. Rather, he should master the fundamentals thoroughly, accurately and practically. He should know how focus is determined; the relation of aperture to focus; why lenses of short focus give greater depth of field; why a long focus lens gives a larger image but has a limited field; why an F:4.5 lens and F:6.8 lens of the same focus will have the same depth of field at F:8; how to use the single elements of convertible lenses and why they require longer exposure; why stopping down gives greater depth and covering power; why a 6 inch anastigmat lens at F:8 is no faster than a 6 inch rapid rectilinear lens at the same stop and so on including all practical every day problems of lens manipulation.

Too much to learn, you say. As a matter of fact, the majority of the above questions are concisely explained in nearly every complete lens catalogue now upon the market.

Present day ignorance concerning anastigmat lenses is mostly due to photographers having eyes but they read not and minds but they think not. It is my contention that every owner of a lens should master it for two very sound reasons; first, to get successful results; second, to get his money's worth.

Let us assume that you have just purchased a new F:4.5 anastigmat lens. What is the quickest way to master its fundamental characteristics as applied to your own work? First, buy a dozen medium speed plates, or fresh twelve exposure film. Go to the subject which you consider to be your hobby or work and focus the camera accurately with the lens wide open. We will assume that you select a bright day for this experiment. Set your shutter for  $1/50$  of a second. Begin with F:4.5 and make one exposure with every succeeding stop until you reach the smallest. Then develop the plates, or roll of film, yourself. See to it that you carefully number each plate, and that you keep the film in the strip without cutting, otherwise you will not be able to distinguish the exposure which fits each stop used.

Next, with the plates, or roll of film, before you and your table of exposures at hand for reference, see what happened. At F:4.5 you probably will obtain an over-exposed negative; at F:8 there is an improvement; at F:16 you have a fairly good negative; at F:32 you get an under-exposed negative and so on to the end. All these exposures, good, bad and indifferent, should give you a clear idea of what "stopping down" really does, what relation the speed of the shutter has to the stop employed, and a realization that as you stop down the exposure must be increased and, conversely, as you increase the aperture the exposure must be shortened.

If you have carefully digested a few fundamentals of lens information, and if you apply your knowledge to the negatives before you, there is small doubt but that you will know more about what your lens will or will not do than anyone else. This experiment is by no means exhaustive, scientific or infallible, but, other things being equal, there is no quicker method of obtaining a speaking acquaintance with your new lens.

From this first rough experiment you may originate any number of subsequent tests which you deem of value to you





BY THE MOUNTAIN SPRING.

George Steele Seymour.



in deciding upon the efficiency of your anastigmat. Individual lens requirements are legion; and it is and would be next to impossible to advance any stated method whereby *every* owner of a new lens could satisfy himself that the lens was right for his purpose. It has always been my opinion that the acid test of a lens lies in the direct application of the lens to the work in hand. If it meets your critical requirements, why worry if it does not test to 1/500 of an inch on a test chart?

Of course, if your work happens to be photographing maps, charts and delicate technical subjects the test chart assumes greater importance. However, if other forms of photography interest you and the lens does your work, let well enough alone,—there are plenty of other matters to take up your attention to better advantage.

As in every field of human activity, photography has its “cranks.” This statement is not made in a disparaging sense. On the contrary, much of the convenience, efficiency and simplicity of amateur and professional photography is due to the man—call him “crank” if you will—who would not and could not be satisfied with “stock” goods, but who demanded and finally obtained “special” equipment suited to his ideas. The “cranks” fussed, complained, suggested and finally compelled the production of the modern anastigmat. Not only that, but by keeping a close watch on the development of new lenses they convinced the lens manufacturers that no lens which failed to meet the highest technical tests should appear upon the market.

Possibly some of the “cranks” were a bit unreasonable in some of their demands, but is it not always better to have a high standard from which a slight digression may be made without serious harm? Hence, if now and then you find a lens in which too much aberration occurs, remember that the “cranks” have paved the way for you to send it to the manufacturer and receive a perfect one in return. Moreover, you are entitled to and will receive courteous treatment. Be sure, however, that you have a just cause for complaint and can honestly state that as far as you know you are in no way responsible for any unsatisfactory result.

One of the rarest, yet most indispensable units in modern

photographic merchandising is the technically trained lens salesman. Such a man is a positive necessity to a photographic community. In a case such as mentioned in the preceding paragraph, he could be of great assistance to both the purchaser and the manufacturer. That there are lens salesmen of this type goes without saying; nevertheless their number is far too limited to meet the requirements.

Any man of ordinary intelligence can master the efficient use of the anastigmat lens, yet it is both pleasant and profitable to talk your experiences over with a man who knows lenses thoroughly, accurately and comprehensively. If you have the good fortune to have such a lens salesman within reach, a word or suggestion from him will save you much needless expense and will also materially increase your chances of success. However, do not lean upon him to the exclusion of your own thinking. Consult, but do not accept any statement without working it out yourself. Do not do this in the sense that you doubt his word but rather that you wish to gain the experience and strength to stand upon your own photographic feet.

For instance, if you puzzle over the statement that on F:4.5 lens of 6 inch focus stopped to F:8 will give the same depth as on F:6.8 lens of 6 inch focus at the same stop, try it out and be able to tell any one *why* both lenses will give the same depth of field. Again, when you hear the statement that an anastigmat lens is faster at F:8 than a rapid rectilinear at the same stop, find out for yourself whether it is true or not. When you discover that the anastigmat is not faster, know *why* it is not.

Remember, whatever accurate lens information you gather should be applied to your work and not written up in a note book where you will never be able to reach it when you need it the most. Formulæ can be briefly condensed in a vest pocket diary and carried with you. As a matter of fact, the average photographer requires only about ten formulæ to carry him safely over any obstacle he may encounter. In all your work make technical data subservient to *results*.

By that is meant the avoidance of a plunge into technicalities with a result similar to that in the old story where it was



DOGWOOD.

ALICE BOUGHTON.

said that "the operation was successful but the patient died"! There are many problems that work out beautifully by means of  $x$  and  $y$  which cannot meet the test of practical application. Theory is to be valued, but good common sense combined with practical theory is the most serviceable combination for the average photographer.

In conclusion let me add that one of the most helpful methods of making an early acquaintance with your new

anastigmat is a *thoroughly digested* reading of all descriptive matter relating to your lens. After which a rough test, such as outlined in the first few paragraphs, will pave the way to a clear realization of the limitations and the advantages of your own anastigmat lens. This is a repetition and intended as such. It cannot be too strongly emphasized that accurately assimilated lens facts constitute eighty per cent of lens success. Also, the way may be pointed out, but each owner of a new anastigmat must become "a law unto himself." The mastery of a lens is a vital necessity to any photographer. It is hoped that these few paragraphs have caused the reader to begin thinking. Wherever there is clear headed thought, we generally find success. Begin to-day to know both *how* and *why* because it pays.



FATHER'S WATCH.

CHAS. W. DOUTT.



Figure 1.

JUNE MIST.

*Illustrating article "Pinhole Photography," by J. A. Ernest Zimmerman.*

## PINHOLE PHOTOGRAPHY

By J. A. ERNEST ZIMMERMANN



THE earliest type of a camera is traced back to the time of Giambattista della Porta, a Neapolitan philosopher. The first description of the apparatus known as the "Camera Obscura" was described in his book, "Natural Magic" published in 1569. This "Camera Obscura" was nothing else than a pinhole camera according to his description, in which he stated: "By admitting a small ray of light through a minute opening into a darkened chamber, the image was reversed—that is top for bottom, and bottom for top."

It is not my intention, however, to bring before my readers the complete history of pinhole photography, but merely to touch upon the most vital part of the subject and to cite a few established facts as to what can be done with it, and to what use it can be put.

It has been my experience whenever the pinhole camera was mentioned among some of my fellow workers, that they would either ignore the subject altogether, or they would pass a few disdainful remarks about it. But why is the pinhole camera regarded as absolutely valueless in this twentieth century of fast plates and lenses? And yet had it not been for Giambattista it is doubtful if the science of photography would have developed as far as it has. The only conclusion that I have arrived at for the neglect of pinhole photography is that it requires untold patience.

But to come back to the technical part of the subject, my



WINTER TIME.

Figure 2.

main object is to bring before the readers of the *Annual* the idea of taking soft-focus photographs, not with a high priced soft-focus lens, but with this simple inexpensive pinhole camera. It can also be said that a pinhole camera, if rightly operated will produce photographs as good as the high-priced soft-focus lens. The one great disadvantage that is offered by the apparatus is the long exposure required, and therefore it cannot be used for studio, and portrait work, or scenery work on windy days. To take views much patience is required and the breezes must be at rest.

The reproductions, illustrating this article, have been made





PORTRAIT.

L. D. SWEET.

with four different pinhole perforations and at different distances from the opening to the plate. The perforations used were as follows: 141 microns, 201 microns, 409 microns and 545 microns. They have been accurately measured and are approximately in the ratio of 1, 2, 3, 4. (A micron is equal to  $1/25000$  of an inch, but the pinholes need not be measured that accurately.) The size as stated can be very conveniently made by exercising good judgment and directions as follows. Take very thin sheet brass, or any other thin metal, that can be easily pierced with an average size sewing needle. Pierce



THE TURN IN THE ROAD. Figure 3.

the metal with the needle just far enough till the point protrudes, this will make an opening of about 100 microns. To make the hole a size larger protrude the point slightly beyond the back of the metal. This will make an opening of about 200 microns, etc. Any desired opening that one wishes to make can be made in this manner. It is however advisable not to go beyond an opening of 600 microns, due to the loss of definition even for the softness of the photograph. Openings should be made upon pieces of metal which are large

enough to fit over the opening of the lens board after the lenses have been removed.

Having pierced the metal disks with the desired openings, let us turn our attention to the camera. The box type can be used as well as the folding type, and those wishing to construct their own camera may do so. It is sufficient to say, as space does not permit me to go into the detail of the construction of the camera, that there are many books and pamphlets on the market pertaining to the subject. The folding type has its advantage over the box type in so far as the size of the objects to be photographed is concerned. Another advantage

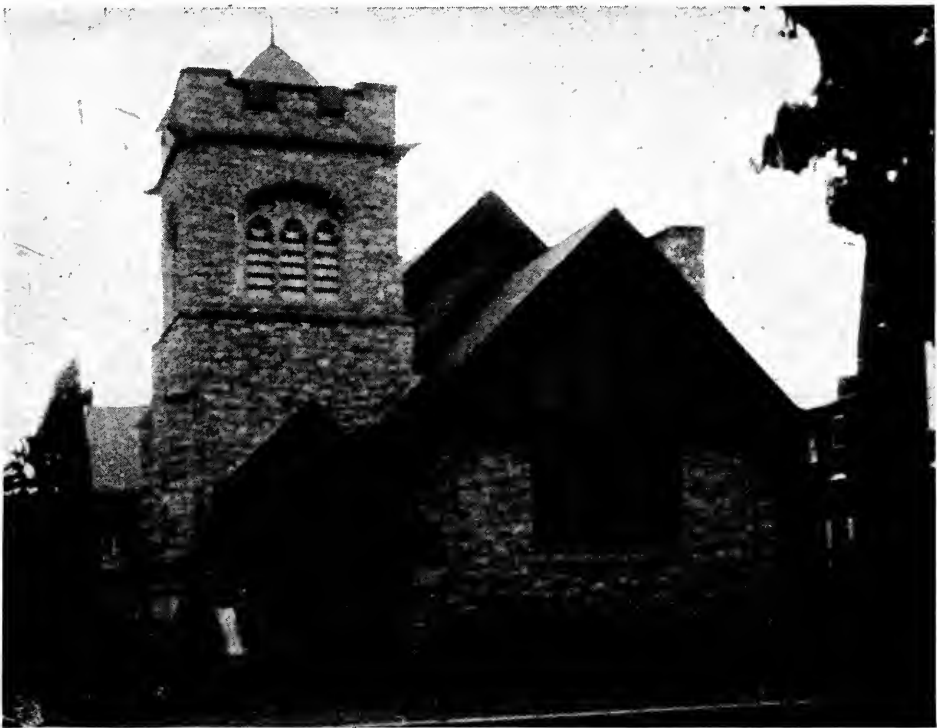

CHURCH OF OUR FATHER.

Figure 4.

is, its different sizes can be seen on the ground-glass. Then again, the further opening is moved away from the plate the smaller the objects, and vice versa, the nearer the opening, the larger the objects. The box type or home-made type will take photographs just as well, distinct and soft as the folding type. Only one size of the object is however obtained with this type of camera owing to the stationary plate-holder.

The exposure of the photograph is mainly based upon the

distance at which the opening is removed from the plate, for instance if the opening be removed from the plate three inches, an exposure of from three to three and one-half minutes will suffice on a bright day. One minute to one and one tenth minute additional exposure of the plate is required for each inch that the opening is moved from the plate. Refer to the end of article for table governing the time for exposures of maximum and minimum distances from opening to plate and to size of the photograph desired.

With a folding camera these respective distances can be marked on the camera bed on the side of the pointer. Film cameras can be used as well as plate cameras, however one difficulty with this film type will always be encountered, namely the removal of the lens from its position when a film is in the camera. With the plate camera this difficulty is never encountered.

If you love real, artistic photographs dear reader, and you have no soft-focus lens try the pinhole method and see the beautiful, soft effects secured. If you do not succeed the first time do not be discouraged but try again, see if you cannot locate your trouble and you are sure to succeed. Here, like with everything else, "Time will bring her own reward."

SIZES OF PLATES COVERED AT MINIMUM AND MAXIMUM DISTANCE, AND BEYOND WHICH DEFINITION IS LOST

Size of Plate Covered	Minimum Distance from Opening to Plate	Maximum Distance from Opening to Plate
2½x3½	1½	2½
2½x4¼		
3 x4		
4 x5	3	8
4 x6	4	
5 x7	5	9
6½x8½		
8 x10	6	12

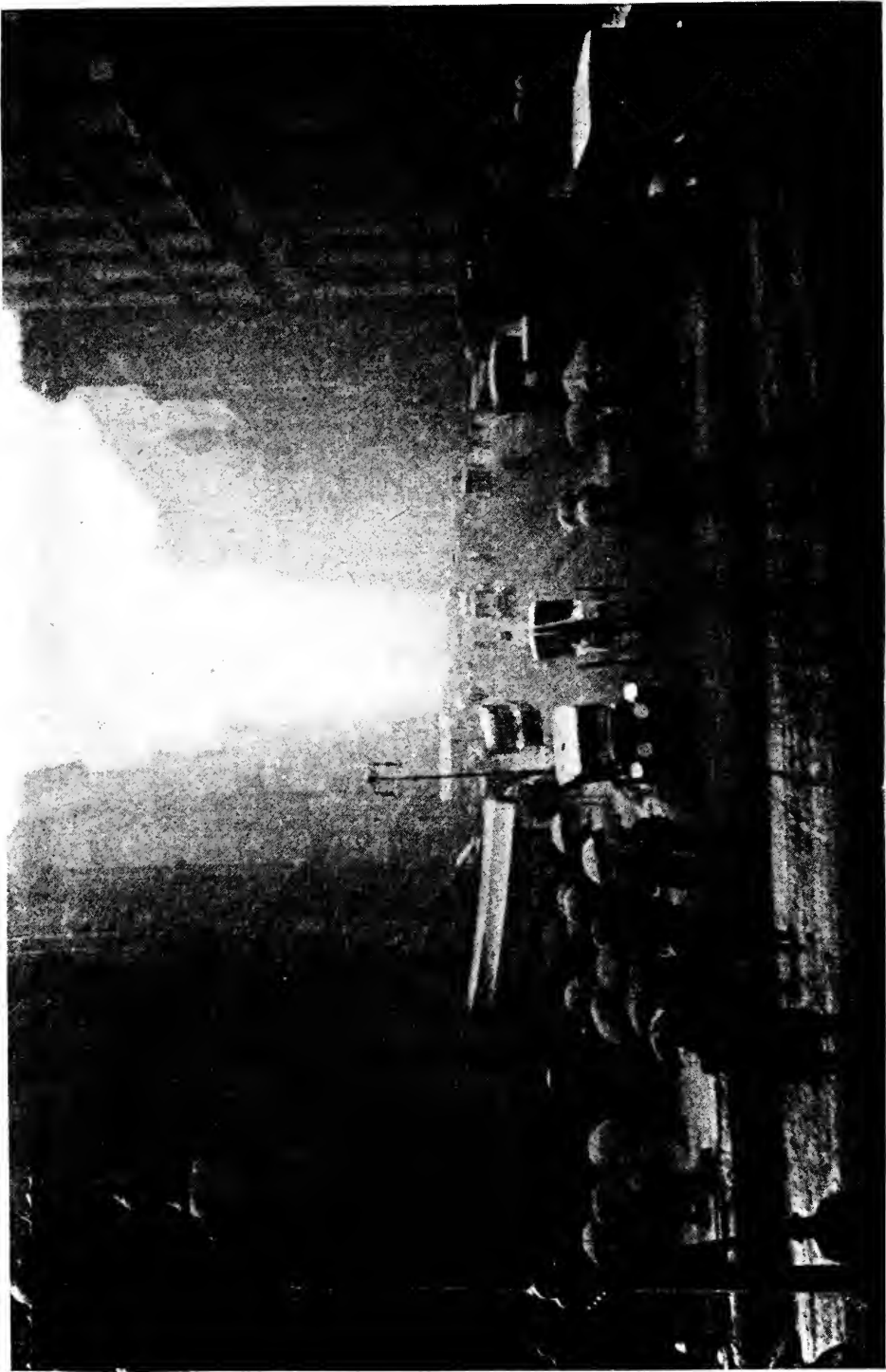

THE IDES OF MARCH.

S. P. EMERICK.

TABLE OF EXPOSURES GOVERNED BY THE OPENINGS. BETWEEN THE HOURS OF 9 AND 3 ON A BRIGHT, SUNNY DAY

Size of Openings in Microns	DISTANCE FROM OPENING TO PLATE IN INCHES									
	1½	2	3	4	5	6	7	8	9	10
	EXPOSURE IN MINUTES									
100	2½	5½	9½	13	16	19	24	27	30	33
200	2	4	7	9	10½	12½	16	18	20	22
400	1½	2½	3½	4½	5½	6½	8	9	10	11
500	1	2	3	4	5	6	7	8	9	10

In conclusion, I give below details regarding each of the illustrations of this article, to give my readers an idea for exposures.

JUNE MIST (Figure 1)—June 13, 1914, 8:11 a. m., bright sunlight. Opening of pinhole 141 microns; distance from plate to opening 3.5 inches, with an exposure of 11 minutes on a rapid 2½ x 3½ plate.

WINTER-TIME (Figure 2)—Feb. 3, 1915, 4:55 p. m., cloudy and dull. Opening of pinhole 409 microns; distance from opening to plate 3 inches, with an exposure of 5 minutes on a 2½ x 4¼ plate.

THE TURN IN THE ROAD (Figure 3)—June 14, 1916, 7:06 a. m., bright sunlight. Opening of pinhole 409 microns; distance from opening to plate 3 inches, with an exposure of 4 minutes on a 4 x 5 plate.

CHURCH OF OUR FATHER (Figure 4)—July 17, 1916, 7:05 a. m., very cloudy and dull. Opening of pinhole 201 microns; distance from opening to plate 5 inches, with an exposure of 16 minutes on a 3½ x 4½ plate. (This exposure was made on a windy day.)



PORTRAIT.

RAE DAVIS.

## NIGHT PHOTOGRAPHY

By ARTHUR C. BROOKS

“This dead of night, this silent hour of darkness,  
Nature for rest ordain'd, and soft repose.”

—Rowe.



WE here consider a class of photography which, to the sceptical, is either impossible of execution or the results obtained through it are not compensatory for the time and materials expended. This state of mind is attributable to the popular belief that as the art of photography is wholly dependent upon daylight as its controlling element it consists of no more nor less than the action of light passing through the lens onto a sensitive plate, night, with its attendant darkness, obviously cannot furnish sufficient illumination to make an impression on the film.

This is correct in the sense that snapshots are manifestly out of the question. We must, of necessity, prolong the exposure to the extent of allowing the feeble light, generally associated with night pictures, to make a visible impression on the emulsion of the plate. It is possible to photograph whatever we can see, regardless of time, place or conditions.

Before approaching the mechanical side of the subject a few words in connection with its artistic interest will assist in the making of better pictures.

Haphazard work in night photography cannot be tolerated. In the daytime it is sometimes possible to secure a good result with little, if any, previous study of the subject; but after dark such chance-taking will inevitably lead to worthless prints. To enter this delightful field of photography with serious intentions it is obligatory that the worker center his efforts on the charm, not the mere novelty, of the subject in hand. It is urgent that he study and try to appreciate the conditions with which he will meet, and when the enchantment and fantastic witchery of Night has once taken its hold





A NIGHT IN JUNE.

Figure 1.

*Illustrating article "Night Photography," by Arthur C. Brooks.*

upon his senses, he will have achieved a long stride toward success.

While the field of endeavor in this instance is commonly conceded to belong only to those times when, in the city, the street and store lights have been ignited and, in the country, the moon is well risen, it is easily possible and advisable to work when the sun has recently set and, filching from the Elegy, "the weary plowman wends his homeward way." The purple-gray lighting helps greatly in assuring an appearance of atmosphere, so desirable here and lessens the exposure considerably.

The Camera: Speaking broadly, whatever can make photographs in the daytime can do the same at night. This is said to confute the impression that special apparatus is required. For the sake of convenience, however, it is prudent to use as good an instrument as it is possible to acquire.

The size of the camera is not a very important topic. To set forth the true significance of the night picture, however, enlarging is usually resorted to, and this should be borne in mind when the negative is first made. A very small camera cannot make an impressive enlargement without showing distressing softness as a consequence. A 4x5 is about the smallest allowable.

A plate camera having a rising and falling front, a ground-glass for focusing, and a swing-back to prevent distortion, is the favorite in common use. The tripod should be as rigid as possible and equipped with rubber footguards to obviate slipping in wet weather. Finally, a rubber cover is needed as a protection against the elements.

The Lens: For the average subject the lens is important only in determining the length of exposure. It is evident that the greater its speed the shorter will be the exposure. The rapid rectilinear is very suitable when used at its largest stop. The accompanying illustration (Figure 1) was made with a 4x5 plate camera and an R. R. lens of six inch focus and working at F/11.

"Flare" is caused by light entering the lens from one side and reflecting in to the plate. This can be prevented by the use of a lens hood.

Plates and Film: The question of whether to use plates or



Rudolf Eickemeyer.



film is optional with the photographer. Many workers consider films, because of their orthochromatic and non-halation qualities, far superior to plates. But they are not to be depended upon for the latter characteristic when powerful arc-lights come into the picture. Too much stress should not be laid upon the prevention of halation as a certain amount of it is necessary to obtain a natural effect. It is expedient to use an orthochromatic plate of as great speed as possible and coated, not backed, with an halation preventive. This last is important, as the ordinary backed plate with its glass side coated with a soluble preparation is not much better than no deterrent at all. Halation is caused by light passing through the film, striking the glass and reflecting back to the film, and it is evident that the preventive should come between the emulsion and the glass so as to intercept the light.

Subjects—Street Scenes: The city photographer will select this class of night work as the most convenient for his purposes. Too wide a view should be avoided; have one object, such as a monument, corner or vehicle, predominate. The bug-bear of moving traffic is frequently met with here, making it necessary to cap the lens. When unlighted conveyances move across the view and when people continue walking this procedure may be disregarded. The exposure will be from ten to fifteen minutes in an open view, and from twenty to thirty minutes when the foreground holds prominent objects. If it is convenient to work from a darkened doorway a great deal of unpleasant observation will be avoided.

Parks: This subject is most popular in Summer, and because of the large number of people to be found at such resorts well-lighted spots should be selected to lessen the time of exposure. When taken at dusk the exposure for park scenery, lakes, etc., is from five to ten minutes. After dark the time runs from fifteen to thirty minutes, according to the light conditions. Illuminated buildings and bandstands need from ten to fifteen minutes, and well-lighted fountains call for but two or three minutes. When moonlight is the chief illumination the exposure is increased somewhat. The moon must not appear in the picture during the main exposure as its movement will streak the plate. Before the plate is ex-

posed tilt the camera upward and include the moon in the view. Then mark its approximate position with a piece of gummed paper attached to the ground-glass. After the main exposure extend the bellows a trifle and expose on the moon for ten or twelve seconds. This slight throwing out of focus softens the image of the moon, which is desirable, and also increases its size. Or a separate negative may be made and the two printed together.

Avoid breezes, as these will cause movement in the trees and so blur the image on the plate. Arc-lights should be shielded with trees and bushes.

Water Scenes: The time selected for this work had best be in the early evening, as complete darkness will most likely prevent the showing of the line of division between water and sky. For harbor views with plenty of lights give fifteen minutes and do not work until "slack water" prevails. This is a nautical term denoting the completion of either high or low tide. Otherwise the movement of the water as the tide advances or recedes will show a noticeable disfigurement on the plate.

The photographing of naval manœuvres at night, while interesting, is extremely difficult work. The constant play of powerful searchlights about the harbor requires the operator to be ever on his guard to prevent the rays entering the lens and thus ruining the plate. If the ships are found at rest and illuminated, the exposure should be from ten to fifteen minutes.

Railroad Yards: The night photographer invariably turns his steps in the direction of the red and green lanterns, before he has been operating a great while. The hiss of steam and the gleaming rail have a peculiar effect upon most persons.

Patience and agility of foot (lest you leave one of them behind!) are the important requirements here. Because of the usual brilliant illumination an exposure of ten minutes may be safely given. Locomotives may appear in the picture providing they are not in motion.

Churches: This is an unusually pleasing subject and not at all difficult. Make the exposure when the service is in progress and the building lighted, giving about half an hour. Ortho-



IN WINTER'S GRASP.

EDWIN J. WHITE.

chromatic plates are required to take care of the colored lights in the stained-glass windows.

Pyrotechnics: This is more of a novelty than anything, but as the lovers of the spectacular may be interested a little space will be given to the subject. Personally, I can see no beauty in a tangle of white streaks, curved or otherwise. However, the camera should be set up at some distance from the maddening crowd, to avoid collisions, and the plate exposed until several bursting bombs have appeared in the view. The camera should be tilted upward so that the heads of the spectators will not appear in the foreground.

Development: The development of the night photograph is all-important. There is as much latitude in the choice of developers here as in all other branches of photography. The individual favorites are many, running from the amateur's familiar Metol-Hydrochinon to the professional's trusty Pyro. It is advisable to use the developer recommended by the maker of the plates. Whatever kind is used should be diluted with water from two to three times the normal solution.

Mr. Robert Dykes of the famous Edinburgh Photographic

Society advocates the formula following:

Stock Solution.

Pyrogallic acid .....	1 oz.
Potassium bromide .....	60 gr.
Potassium meta-bisulphite .....	50 gr.
Distilled water, to.....	12 oz.

No. 1

Stock solution .....	3 oz.
Water (boiled) .....	2 oz.

No. 2

Soda sulphite .....	2 oz.
Soda carbonate .....	2 oz.
Water (boiled) to.....	20 oz.

Use 4 drams of No. 1 to 5 drams of No. 2 in 16 oz. of water. To complete development rinse the plate in a stronger solution, viz., one ounce of the normal developer, (equal parts of No. 1 and No. 2) in eight ounces of water. Do not allow the plate to remain in this bath more than one minute; it is used only to strengthen the detail.

There is a short scale of tones in this work and the worker should avoid contrast in both the exposure and the development of the plate. The proper night photograph should have softness, absence of harsh contrasts and detail in the shadows.

Fixing: The fixing bath should be stronger than normal as there is so much silver to be dispelled. Shield the plates from all light and leave the ordinary plate in the bath for 20 minutes. The double-coated plate should remain from 30 to 40 minutes.

These negatives are prone to defacement as the emulsion is thinner than the average, and it is best to varnish them to prevent accidents. Flow the varnish across the plate and stand on one corner to drain and dry.

While these notes have discussed but a few of the many subjects available to the night photographer, the writer trusts that they will serve as an incentive to those workers who have held no faith in the possibilities along this line, to include the work in their efforts as camerists and so realize the truly artistic results which await them if they will but work with serious intentions.





REFLECTIONS.

L. M. A. ROY.

## GUM-PLATINUM

By GUY SPENCER



VERY artist-photographer, striving for ideals, welcomes any means by which his medium of self-expression may be enriched, irrespective of the study and labor involved. For absolute permanency and fine pictorial effect there is nothing so completely satisfactory and pleasing as a Gum-Platinum, consisting as it does, of a coating of gum-bichromate super-imposed upon a finished platinum print. Though it comprises two printing processes the beautiful and distinctive results certainly justify the effort.

These remarks are intended to draw the attention of those who have never entered this most interesting field, and to indicate simple methods of working. It often happens that one wades through a voluminous mass of detailed information with a consequent muddling of understanding, when an elementary experiment along the line will establish a starting-point from which the individual may wander at will into intricate combinations.

Throw aside the fancied notion that Platinum is hard to handle. If the negative be thin and soft print in the shade until a slight image is visible; if of normal density, allow the action of light to go a little farther. A few trials will determine the depth of printing. The immersion in a solution of neutral oxalate of potassium dissolved in sixty-four ounces of hot water used room-warm followed by a bath in hydrochloric acid C.P one dram to eight ounces of water are hardly worth considering from the standpoint of difficulty.

Leave the print in the oxalate until the desired tone is reached, clear for ten minutes or so, wash and dry. The instructions accompanying Platinum paper are very comprehensive and easy to follow.

Now make a try-out of the gum. Obtain from the druggist one ounce gum arabic *in lumps* and one ounce bichromate of potassium. Tie the gum in a piece of cheese-cloth; suspend in a wide-mouthed jar containing four ounces of cold water. Dis-



A TREE THAT BENDS.

*Illustrating article "Gum-Platinum," by Guy Spencer.*

solve the bichromate in nine ounces of hot water. It will be a day or two before these chemicals are ready for use. Get a soft brush, preferably set in wood, three or four inches wide, and a tube or two of pigment, say ivory black and burnt umber to begin with. Into a flat dish squeeze out about two inches ivory black, or black and burnt umber, according to your choice of tone, pour on two drams of the gum solution, blend thoroughly, then stir in four or five drams of bichromate, mix well together and filter. Place several thicknesses of newspaper on a flat board, pin over this, by the four corners, a sheet of charcoal paper or a good quality linen writing-paper (minus water marks) larger than the negative. Charge the brush, but not too fully, coat the paper *smoothly* and *quickly*, first with downward strokes, then cross-wise; avoid streaks. The secret of the operation is a sure quick stroke that comes with practice. *Dry in a dark place.* Now make a test exposure taking as your guide a piece of Kresko. Expose the gum for about the same time. Development consists in soaking out the pigment not wanted. Put the print face down in a tray of cold water, and leave until the excess pigment is dissolved away. Lift gently by one corner to note progress. If under-exposed the pigment washes off at once, if over-exposed it may take hours to develop. You can help some by using hot water, or laying it face up on a piece of glass and allowing a gentle spray of water to play upon it. Dry flat. If it does not come out to your taste, try again.

When you have progressed to this point with efficiency take some under-printed Platinum for a trial. Coat as above, being careful not to use too much pigment. Place the negative and paper in contact, hold up to a strong light and register accurately. After this you are ready for the Platinum with a view to a gum finish, in which case print first for the high lights, develop, clear, wash and dry; then coat with gum; print for the shadows.

Gum-Platinum, though requiring care and patience, is an extremely interesting process, lending itself to modification of values, and adding to the beauty of Platinum, the richness of gum. It is specially adapted to prints of large size, rendering landscape as well as portraiture with a distinction impossible to acquire by any other method.



AN OLD INHABITANT.

*Illustrating article "Gum-Platinum," by Guy Spencer.*

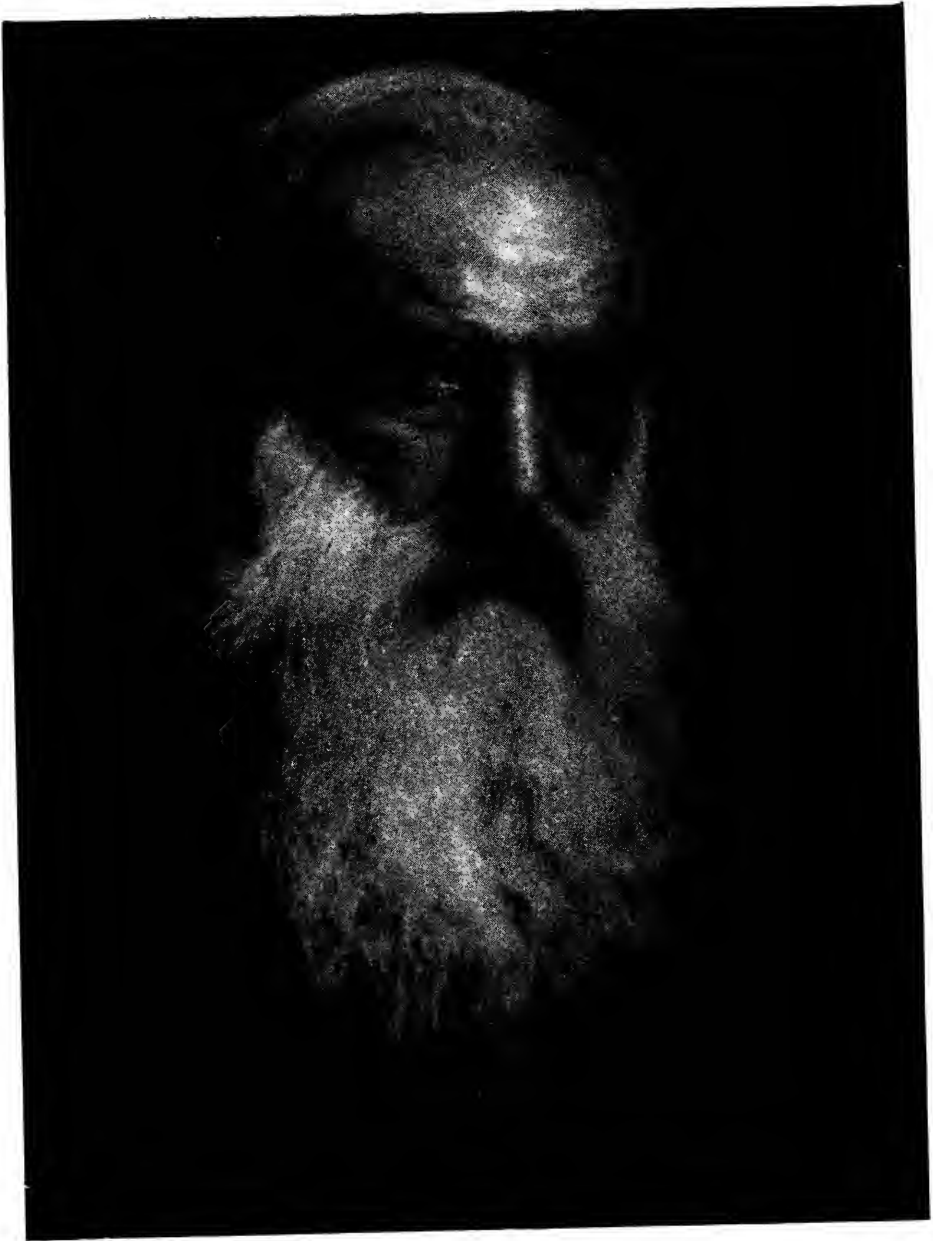

Figure 1.

HEAD STUDY.

*Illustrating article "The Photographic Portraiture of Men," by T. W. Kilmer.*

# THE PHOTOGRAPHIC PORTRAITURE OF MEN

By T. W. KILMER

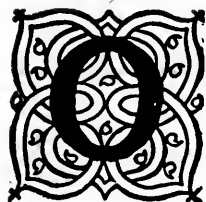

ONE'S hobby, no matter what it may be, often narrows down in this age of specialism to a hobby within a hobby. Such has been my case with photography. For the past few years my course has taken me drifting idly down Pyro river, stopping occasionally at Metol Island, finally landing me against the tall, stately cliffs of the Portraiture of Men.

There is something fascinating to me about making a portrait (not just a *picture*) of my men friends; possibly I am growing sentimental, but at any rate there is great satisfaction in seeing the faces of my associates in my chosen profession, and my college friends, indelibly portrayed by the action of light, upon my study walls. I can there sit and without a great stretch of the imagination talk to "Bill" or "Teddy" or "Tom," going over the past or anticipating the future.

It is alright to dwell upon the various lightings of the face bringing out the character of the man, but I believe the best portraits in photography are those taken of a person and by a person who have known each other a long time. Let me try to make a portrait of an old friend and another of a new acquaintance, and the one of the old friend is the better one every time; therefore, if you intend to make good, lifelike portraits, *know your sitter*. The three appended prints (Figures 1, 2 and 3) are selected at random as showing what may be done with an 18 inch soft focus lens, an 8 x 10 plate, and ordinary daylight.

Let us say that you have decided to make a photographic portrait of one of your men friends, how should you go about it? My rule is to first get the fellow interested in having his portrait made. Show him a portrait of somebody whom he knows and usually he says, "Say, if you can take a picture that looks as much like Jim as that does, you can get a good one of me." At once he feels that *he* will not have to *do* any-



Figure 2.

PORTRAIT OF B. W. STIEFEL, M.D.

*Illustrating article "The Photographic Portraiture of Men," by T. W. Kilmer.*



thing to get a good picture of himself; *you* will do everything. As soon as a sitter feels that he is obliged to *help* you take his picture you will never get a good one; it is that feeling of relaxation that gives the best expression.

I am strongly in favor of the soft focus lens for portraiture, and never use one of less than 18 inches for an 8 x 10 plate. The extension of the usual 8 x 10 view camera is not sufficient for an 18 inch lens, so I have been obliged to employ a 11 x 14 camera with a back for 8 x 10 holders. All of the appended portraits (Figures 1, 2 and 3) were taken with this outfit with daylight as an illuminant, although I am extremely fond of the mercury-vapor light, as it is even and always the same.

My plates are a cheap grade of ordinary dry-plate, and are tank developed with metol or Pyro. There is no paper to my mind that surpasses Artura (especially grade E, rough) for portrait work. In using either daylight, or artificial light, it is quite necessary to employ some sort of a diffuser; personally I use various thicknesses of black tulle.

Do not have your sitter in a low chair; use a high one, bench or table. Do not try to incorporate a whole lot of so-called artistic lighting, expression, individuality, etc., into your portrait. Remember that there are no two persons who can take *exactly the same* photograph of anything, so that your portrait is bound to have individuality.

Also remember that it is a *likeness* of the sitter for which you are striving, and any print however so well-lighted and artistic, if it does not *look* like the sitter, is fit for nought but the scrap-heap. Make your sitter comfortable, and happy, let him sit down anyway he chooses, and then make a portrait of him, that above all else, *looks like him*.

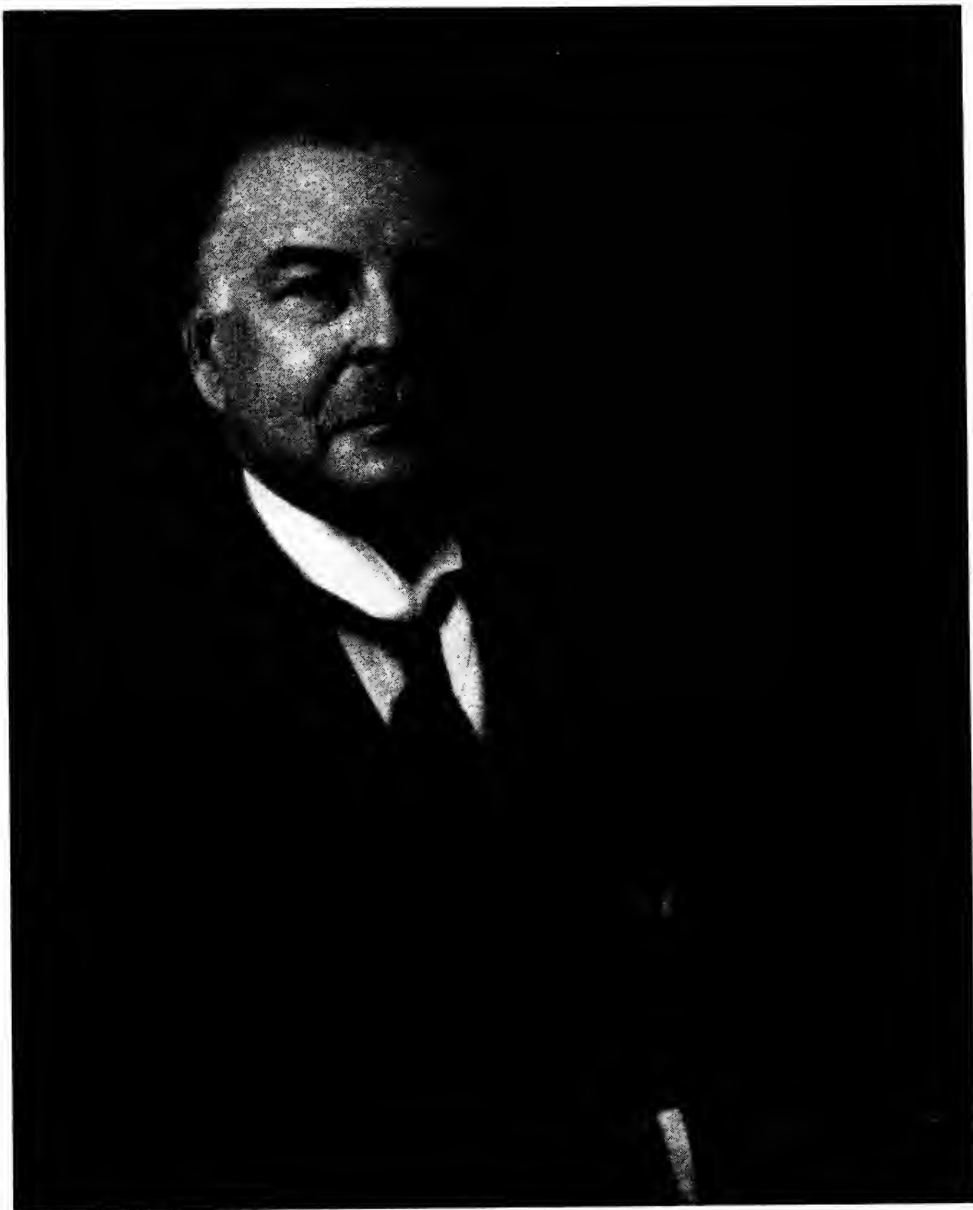

Figure 3.

PORTRAIT OF E. L'H. MCGINNIS, M. D.

*Illustrating article "The Photographic Portraiture of Men," by T. W. Kilmer.*

## COLOR-PHOTOGRAPHY

By WAYNE MORRIS



AS the photographer—amateur or professional—ever lived who has not dreamed of reproducing on the sensitive plate the colors of nature as they appear on the ground glass focusing screen? Such conservatives, if they exist at all, are few and far between. And now since practical processes of color-photography have been discovered, it is amazing that the art is not more extensively practiced. The so-called “screen-plate” processes have been developed to such an extent that they can easily be mastered by any amateur and are almost as simple as ordinary photography.

Of the two leading screen-plates, the Autochrom and the Paget, I prefer the latter. Each has its advantages, however. The Paget plate is the more transparent, and any number of duplicates can be made from the original negative as well as black and white transparencies and prints of wonderful tone and correct color value rendering. All this is impossible with the Autochrom. Besides this the manipulation of the Paget plate is very much like black and white photography, and is therefore more easily mastered by one familiar with this process.

The disadvantage of the Paget plate as compared with the Autochrom lies in the fact that the negative plate must be exposed through a “taking screen” which must be held in perfect contact with the plate, and the positive made from this negative must be viewed through a similar “viewing screen” registering in the exact position that the taking screen occupied in relation to the negative. Both of these disadvantages, however, can be overcome entirely, or reduced to a minimum, by the exercise of a little skill.

The manufacturer of the plates advises the use of a specially constructed plate-holder for holding the taking screen in perfect contact with the negative plate, but such equipment is

generally too expensive for the beginner in color work who at the onset is usually just experimenting. It is entirely unnecessary too for I have been able invariably to obtain perfect results with no other equipment than that which is used in ordinary black and white work, and with which almost every photographer is supplied. The only condition is that a camera taking a larger size picture than the intended color picture shall be used.

Suppose you wish to take a 4 x 5 color picture. A 5 x 7 or larger size camera is necessary. Get a kit taking a 4 x 5 plate to fit the regular plate-holder. Now, provide yourself with a number of pieces of paper and thin cardboard about 3 inches wide by 4 inches long. Insert the negative plate and the taking screen into the kit, placing the taking screen in first so that its corners rest on the metal strips that hold the corners of the kit together. Place some of the pieces of paper and cardboard in the center of the plate-holder so that the plate, but not the kit, will rest on it when the kit is fitted into its place. The next step is to place the kit *upside down* in the plate-holder so that the metal strips across the corners of the kit will press down on the four corners of the taking screen which will be on top. If a sufficient amount of paper and cardboard has been placed in the plate-holder first, the negative plate will be pressed up against the taking screen and perfect contact will be secured.

A little experimenting will determine the proper amount of backing to use in the plate-holder. Care must be taken not to use too much, as too great pressure will break the negative plate or the taking screen. With a little practice the whole operation can be performed very quickly and easily. As one side of a kit is usually beveled in order to make it fit in the plate-holder it may be necessary to bevel the other side with a sharp knife in order to make it fit upside down. I have loaded plate-holders in this manner in daylight by using an ordinary black loading bag. Great care had to be exercised, however, in order to be sure to get the film side of the negative plate next to the film side of the taking screen.

Another difficulty that many encounter in manipulating the Paget process is to get the positive plate and the viewing screen



EDGE OF THE ROAD.

Theodore Eitel.



glued together in perfect register. This can be done very easily by the following method: After one has succeeded in getting the two plates in perfect register by following the printed directions found in every box of plates, catch the two plates which form the picture in the center between the thumb and fingers of one hand. Have a pointed match stick and an open bottle of glue handy. With the free hand dip the point of the match stick into the glue and touch the edges of the plates in a number of places with the glue on all four sides. Now, carefully lay the transparency down on a flat surface and allow it to dry. After a half hour or so it may be examined. If the registry is perfect, it can be allowed to dry thoroughly and bound as a lantern slide. If the registry is not perfect, the glue will still be soft enough so that the plates can still be moved just enough to throw them into perfect registry.

Color work is so much more fascinating than black and white that one does not mind the extra pains required. And besides it has many advantages. Little attention need be paid to composition. The colors have a way of their own of balancing a picture that is surprising. Besides this black and white prints made from negatives taken by the Paget color process show a color value rendering that it is simply impossible to get in any other way. Anyone who has not made a print in this way has never done perfect black and white work.



WASHINGTON BRIDGE, HARLEM RIVER.

HASWELL C. JEFFERY.



Figure 1.

THE AFTERGLOW.

*Illustrating article "Sunset Photography," by A. Brooker Klugh.*

## SUNSET PHOTOGRAPHY

By A. BROOKER KLUGH

**T**HERE is nothing more effective pictorially than a good sunset, yet we see comparatively few sunset photographs. There are probably three reasons for this; firstly it is not every locality that is capable of providing such pictures; secondly, the subject is a fleeting one, one which must be watched and waited for and caught at the psychological moment; and thirdly, a good many photographers seem to regard the subject as an extremely difficult one.

A sunset to make a good picture must be viewed with a body of calm water as a foreground (Figures 1 and 2). I am inclined to lay this down as an axiom, as it has been my experience that the best sunset with a land foreground is decidedly disappointing. For one thing a sunset picture depends





FROST AND MIST.

J. R. PETERSON.



MORNING MIST.

A. L. HITCHIN.

very largely for its effectiveness upon the reflection of the clouds in the water, and another point is that it is absolutely impossible to adequately expose for a land foreground with light of such low actinic value as prevails at this time of day and not greatly over-expose for the sky. Thus it is only in locations from which we can view the western sky over water that we can make good sunset photographs.

If one happens to live right on the spot from which such a view may be obtained it is not of such great importance that the glories of the sunset are so evanescent, but if to reach such a location means a walk of a mile or two then, towards evening, one must watch such parts of the sky as may be seen for cloud-forms which will give an effective sunset picture, and when indications are good set off at once for the view-point.

While water is the best foreground for a sunset picture a mere expanse of water and sky does not make a satisfactory picture. There should be something in the mid-distance to relieve the bareness. Islands, a range of hills on a shore a



PORTRAIT.

KNAFFL & BRO.

mile or two away, or coniferous trees a quarter of a mile or so distant contribute much towards such pictures.

It is perhaps hardly necessary to say that successful pictures cannot be obtained as long as one can see the sun. It must be either behind a cloud, behind some object in the mid-distance or below the horizon. Of these alternatives the two latter are better than the first, as if the sun is behind a cloud it is likely to give a very contrasty effect that has more the appearance of moonlight than of sunset, or to give a stormy look to the sky.

As far as the technique of sunset photography is concerned the main points are the use of a ray filter and orthochromatic, backed, plates. The filter should be fairly deep, about a five-times filter being my preference. In developing such negatives they should be kept thin, as otherwise the delicate cloud details are lost and the pictures are too contrasty. They should be printed on glossy or semi-glossy paper, and if contact prints are made they are more effective on P.O.P. than on the developing papers.



Figure 2.

SUNSET ON THE STRAITS OF GEORGIA, BRITISH COLUMBIA.

*Illustrating article "Sunset Photography," by A. Brooker Klugh.*

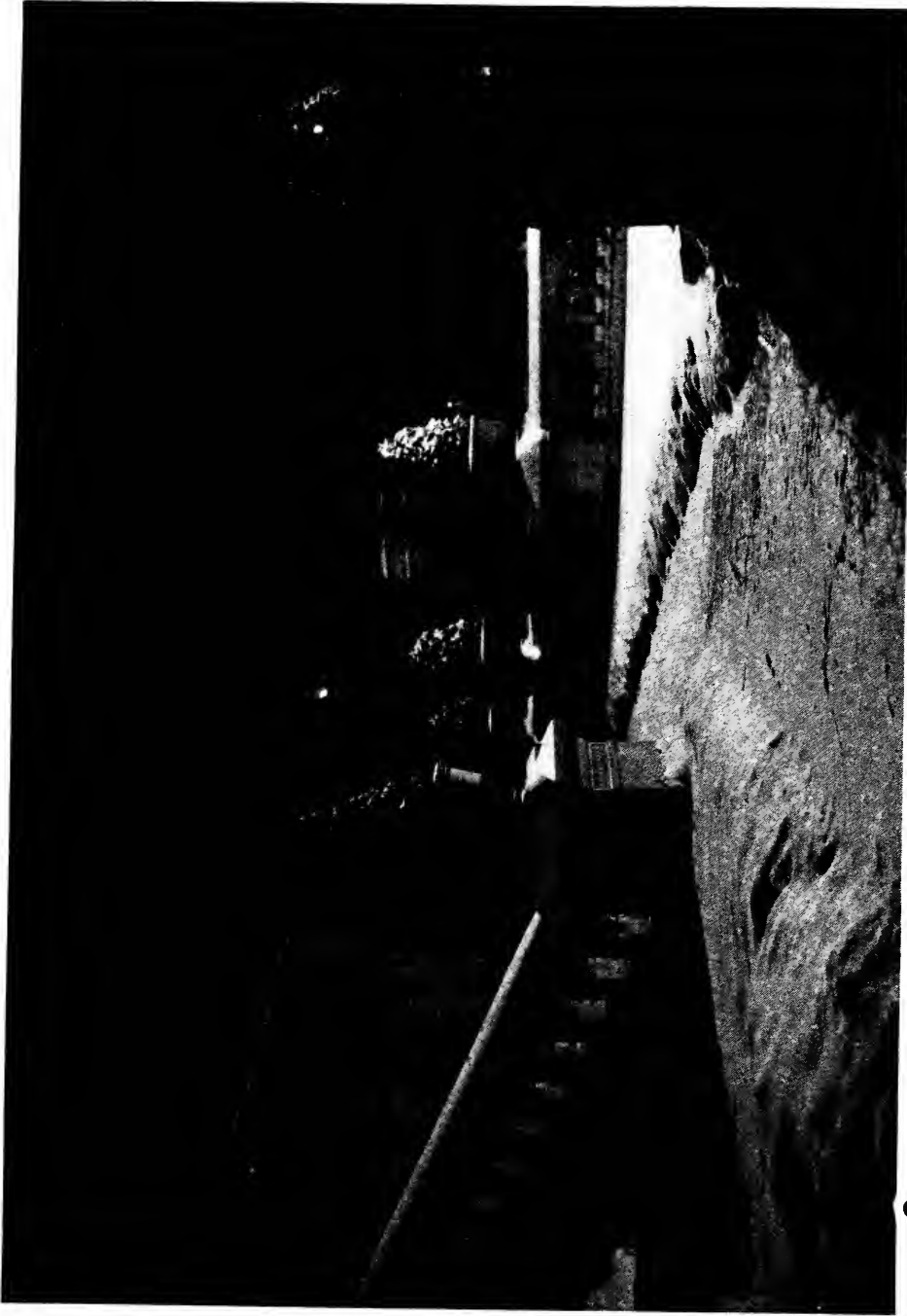

NIGHT—WEST TERRACE, UNITED STATES CAPITOL.

E. L. CRANDALL.

## PRACTICAL POINTS ON THE VEST-POCKET CAMERA

By A. W. H. WESTON



IN theory the little camera is ideal. It is only in practice that we see little difficulties, which, although slight in themselves nevertheless interfere with the full efficiency of the system.

The claims of the little camera have been elaborated many times, but it may be as well to briefly enumerate them here before proceeding to more practical points. First then the miniature size of the camera enables it to be carried on all occasions so that it is always to hand even for the unexpected. It can be used unobtrusively, and when noticed few people take such a little thing seriously—an advantage in securing natural figure studies, etc.—while the low cost of plates does not cause us to hesitate in its use—even in war time.

The optical advantage of a short focus lens enables us to secure great depth at a large aperture, while small shutters are more efficient and can be used at a higher speed. All these are real substantial advantages which make the little camera ideal.

Tiny negatives are of very little use unless they are enlarged and enlarged many times, and for this reason the little negative must be very near perfection or the result will be very indifferent. There must be no pinholes or scratches whatever. The image must be critically sharp, and the class of negative must be such that from the highest light to the deepest shadow there must be printable detail. A negative that will only give a very good contact print will not do if we are to get the best out of the little camera. It is for this reason that throughout we must exercise far greater care than in making negatives for contact printing or slight enlargement. Every negative must bear critical examination with a good focusing glass before it will serve its purpose, and it is interesting to see how few of our larger negatives will bear this test, although they serve



PORTRAIT.

Belle Johnson.





their purpose. Much greater care must be observed in handling the plates so that they reach the washing tank absolutely free from dust and finger marks. If single slides are used a short bone knitting-needle filed flat and with the point off is in some ways better than the finger-nail for removing the plate, as with the nail it is difficult to avoid touching the film with the finger. Tank development is an advantage too as it does away with a lot of handling of the plate. In any case the plate should always be held by the edges. Even when washed and dried the negative must be treated with care as a slight scratch on the surface will show badly in enlarging.

Another cause of trouble in enlarging is the grain of the plate, and if the exposure has been short so that the image has been forced up in development the grain will show. Sufficient exposure should be given to enable development to be carried out with a slightly restrained and diluted developer and this will minimize the grain. The slow action of tank development will also tend to produce fine grain, in fact it will help matters if all the operations of developing, fixing and drying are carried out slowly.

The small negative must be critically sharp so that accurate focusing is an important matter. It is true that the depth of focus is very great but with a large aperture such as F/4.5 focusing is necessary for anything fairly near *simply because we are not making negatives to print by contact, but to enlarge many times*. When we realize that a misplacement of the camera front by 1/50 of an inch will cause noticeable unsharpness in an enlargement we see how important it is that there should be absolutely no play in the focusing arrangement. On some of the highest class cameras now on the market the focusing indicator soon develops a certain play which quite spoils the efficiency of otherwise beautifully constructed instruments.

When circumstances permit the image may be focused on the screen with the aid of a focusing glass, but it is not wise to attempt it with the naked eye, far better to rely on one's judgment of the distance and focus by a trustworthy scale.

Another cause of trouble is movement of the camera during exposure, and this is more frequent than might at first be

supposed. To keep a tiny camera still for an exposure of  $1/10$  to  $1/50$  of a second is more difficult than with a camera of heavier build, and the slightest movement shows *simply because we are not making negatives to print by contact but to enlarge many times*. Some sort of support should be used for the camera whenever possible and as a larger aperture may be used than for a camera of larger and consequently heavier build it seems poetic justice that a quicker exposure is more often possible.

But if the little camera is weak in the slower instantaneous speeds (and of course if a firm support is provided for the

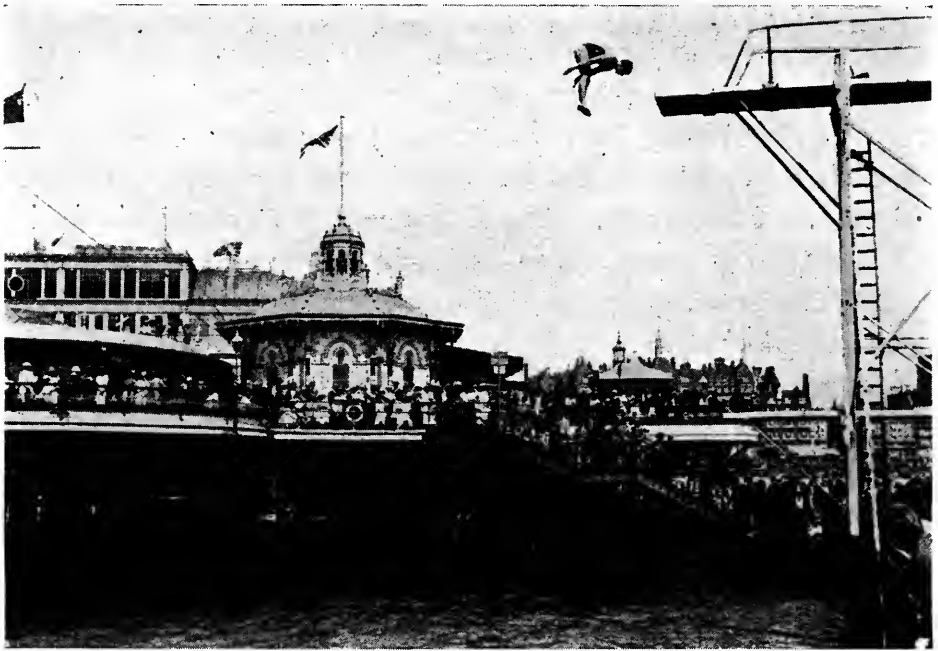

Figure 1.  
HIGH DIVING FROM THE WEST PIER, BRIGHTON.  
*Taken with a vest pocket camera at  $1/300$  part of a second.*

camera any length of exposure may be given and for portraits it is very useful to have a shutter giving exposures from one second) it is particularly successful with the faster exposures for not only is there then no fear of movement, but the shutter works more efficiently than with a larger camera which means that more light reaches the plate in a given period. To have a shutter working up to  $1/300$  of a second is useful on occasions (Figure 1), and there is something particularly satisfactory about using these higher speeds when permissible.



DANISH MOTHER AND CHILD.

HELEN W. COOKE.

It is unfortunate that the various features that seem to be most desirable in a vest-pocket camera do not appear to be embodied in any one particular camera on the market.

Most of the best cameras open on the lazy tongs principle which gives admirable rigidity to the front. When closed the lens and camera front should be protected and should have no projections. This enables it to be slipped in the pocket without a case and without risks. The ground glass too should be protected by a collapsible focusing hood. The lens should be of the highest possible grade, preferably working at F/4.5 and of 3 inch focus. The shutter should be a compound working from 1 sec. to 1/300 part T. and B. with the release in a position to be worked with the least jar. The view finder should be a wire frame giving a full size image and finally the focusing indicator should be on a system that will not develop the least play. A camera constructed with these features should leave little to be desired.

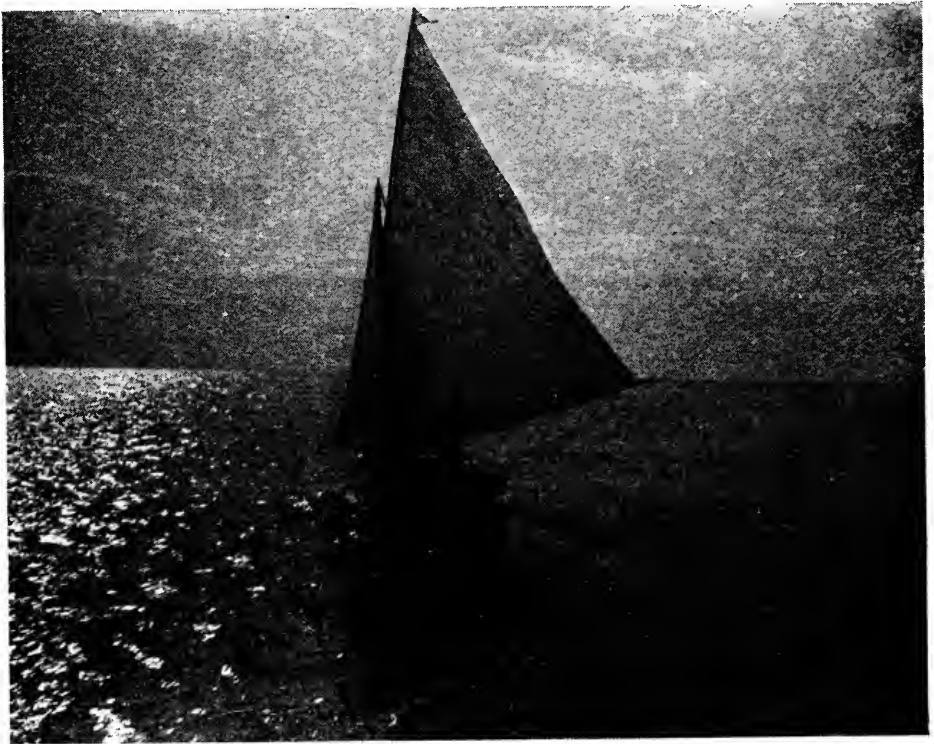

MAURICE THOMPSON.



LADY AND THE FAN.

HARRY D. WILLIAR.

## STUDIO COUPONS—WHAT SHALL WE DO WITH THEM?

By JESSIE ROBINSON BISBEE



THE popularity of the fallacy "something for nothing" is probably as old as humanity. No doubt primitive man in some way or other tried to prove its glittering promises real. The world is still trying the theory out. Pick up any daily paper and you will find the "something for nothing" idea elaborated upon in all sorts of sparkling appeals. How many times have you seen advertisements offering everything from a pin to a piano "at less than cost"?

The average American consumer is eager indeed for anything that looks like a bargain—something for nothing, or something for less than it ought to be worth. It is not strange that this national tendency should have an influence upon the photographic profession. Perhaps its result is most pronounced in the widespread coupon system. From the Atlantic to the Pacific, from Canada to Mexico, city studios and small town studios alike have used the coupon or ticket plan for stimulating business.

Coupon selling is a profession in itself and the forms of coupons are many and varied. But all meet on the common ground of a reduced price; for instance, by purchasing the magical ticket or coupon, the buyer may receive two photographs worth \$25. a dozen for "50c to the salesman and 50c at the studio." Sometimes the salesman collects a dollar with the same amount payable at the studio; sometimes he collects a dollar with the understanding that nothing is to be paid at the studio. But it matters little about these differences in coupon plans for the principle is the same: the customer is getting the pictures at a greatly reduced price, sometimes at less than half-price, sometimes at about twenty per cent of the average price for the same work in this same studio, and sometimes he gets the pictures for nothing—merely for the walking away with them!

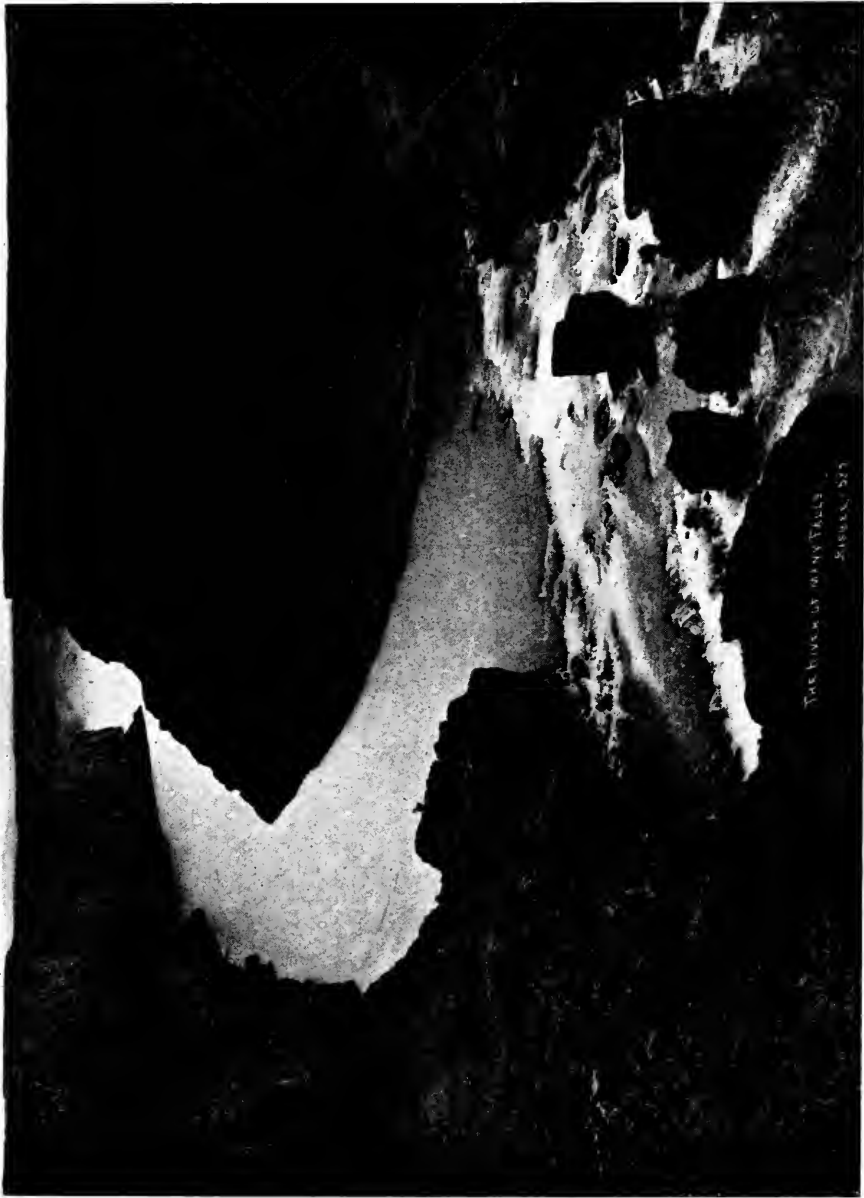

THE RIVER OF MANY FALLS.

CLARENCE E. BISBEE.

Such a proposition is fundamentally unreasonable and it is economically unsound. One price or the other must be wrong. No photographer who is justified in asking \$25 a dozen for portraits can possibly afford to sell two for \$2 which is the reading of a very popular coupon ticket. In reality, he sells two for \$1, for the agent, of course, keeps the first payment.

A photograph should mean something more than mere finished material. It is not merely an exposed plate, a finished and mounted print. It should mean thought, skill, ability; it should mean the careful interpretation of each sitter's best characteristics. The product of brains is high-priced in these days in any line. Why should a photographer not charge for knowing how?

Knowing how is the open sesame to success; why should a photographer overlook it? A master mechanic was once called to a certain factory to find a break in the machinery. Many laborers were idle while the machinists had searched in vain for the trouble. The master mechanic came and found the cause in about ten minutes; he repaired it in even a shorter time. He presented his bill—\$50:50. The superintendent of the company was puzzled. "We are willing to pay you what you ask," he said, "and we consider this charge reasonable, but I would like to know how you happened to add the 50c to your bill." "Why that is for turning the bolt that adjusted the trouble," the mechanic answered. "Then what is the \$50 for?" "That," replied the mechanic, "is my charge for knowing how." Sometimes I think that photographers are the only people who entirely neglect to charge for the knowing how part of their business.

Then there is the item of over-head expense. The coupon photographer reasons this way: the plates cost 15c, the paper 10c, the mounts 15c; charge a dollar and the profit is 60c. He forgets rent, equipment, heat, light, telephone, service, and time, and that precious element that life itself is made of—he forgets all but the mere profit on material.

Of course the coupon photographer and the coupon salesman will present their argument at this point; it is always this—the profit comes on the sale of duplicate prints. So it does. But what is charged for the duplicate prints? Photography, like printing, like anything else requiring individual treatment,





SKETCHING.

G. W. Harting.



presupposes the heaviest expense and the most work must be expended in getting ready to make the first copy. The making of the negatives, the submitting of the proofs, the retouching, all must be correctly done even though but one print is ordered. It is because of this that the average studio charges about a two-thirds rate for the first half-dozen. This is reasonable and is accepted as just by the public.

But the coupon studio reverses this. The coupon studio delivers the two 8 by 10's mounted for \$2 and for the duplicates often quotes the price at \$1:50 or \$2 each. This is inconsistent and the average purchaser of photographs knows it. She knows well that photographs should cost more in small quantities than in larger numbers. She presumes that the photographer is making a profit on the first transaction—why should she not think this, for she is paying the price he set for himself—and she resents the paying of the advanced price for duplicate prints.

Generally speaking, there are two kinds of regular coupon studios; the one, usually located permanently in a city and putting on one coupon whirl after another, and the travelling coupon studio, going from town to town with aggressive ticket campaigns and leaving as soon as the deadly business reaction begins. I admit that both of these studios, as a rule, are successful in the sale of duplicates; they have to sell them; it is their fight for existence; they must practically force the duplicate orders upon their customers or close their doors. The receptionists in these studios must book high orders by any means at their command or their usefulness is over to the studio which employs them. It is a commonly understood fact in some of the larger coupon studios that the order must be placed before the negatives are made; he who hesitates gets a blank plate in the posing-room. Often it is hard to get early appointments for coupon sittings until mention is made of wanting extras or smaller pictures finished.

These methods are unethical and unworthy of the photographic profession. Any photographer should be ashamed to secure business in this way. Many photographers who hate such a system and the rather questionable standing it gives a studio feel they are forced into it by competition. Don't do it—don't do it. And I am not speaking idly here for in our own

studio we know what it is to fight coupon business, both the coupon campaigns of resident and permanent competition and those of travelling coupon concerns. But we have never put out a coupon and we never will—not if every other photographer in the state does it, not if they all do it at the same time. If the time ever comes when we can not maintain our business by good workmanship, courteous service and legitimate advertising, we will certainly close our doors.

Of course the coupon salesman will maintain that coupons are a channel for legitimate advertising. "A man has a right to make two 8 by 10's for a dollar if he wants to do it." Time and again professional coupon salesmen have impressed this fact upon my mind in exceedingly ruffled tones. Certainly he has a right to do it. A man has a right to go out to our thousand-foot canyon and jump over into it if he wants to do it. The state would interfere if it knew it in time, but usually the state knows nothing about such cases until the thing is done. However, when we read of the person who took the river route, or the canyon jump, or the blowing-out-the-gas way to destruction, we do not say, "Here is a man who used his liberty, who did what he had a perfect right to do." We are more likely to say "Poor fellow, his mind was unbalanced when he committed suicide." Most assuredly it is within the rights of any photographer to imbibe the coupon idea, but it is pretty likely to be fatal both to reputation and finances sooner or later. You will find very few coupon photographers listed in Dun's or Bradstreet's. Many of them are not gilt-edge risks in a financial way; ask their dealers.

The coupon man places strong emphasis upon the crowds coupons bring into the studio. Coupons do attract a crowd, indeed, but every department store in the land knows it is far easier to draw a crowd than it is to make a profit upon it. The business that coupons bring a studio is abnormal; abnormally crowded as to sittings, usually abnormally poor as to workmanship, abnormally ridiculous as to price. And abnormal things and times of any kind are of doubtful benefit.

The believers in coupons make full use of the argument that all stores have cut-rate sales. Stores do have sales, and with a good reason, for a merchant must deal with rapidly changing styles, with seasonable materials and with perishable goods.



CHILD PORTRAIT.

O. C. CONKLING.

The photographer has not one good excuse for making photographs more cheaply in one month than in another. Though it is a fact that in his strange way of reasoning, many a photographer puts on a holiday offer or discount for the month of December when every reputable studio should be more than busy with regular work at regular prices. And even though most stores do have special sales, no store ever sold a can of corn at 13c one day and at 1c the next. Every woman in the town would be fearing ptomaine poisoning if it did. And yet this is parallel with the average coupon offer and with about as much logic.

Would a theater manager put on the best play of the winter at half-rate? Would he open the doors to the people and say, "Come and sit without money and without price"? No, indeed. But a photographer will give his largest and best work away for a song and will insult and degrade it by tying a coupon to it. The theater manager now-a-days makes his house pay a fair percentage of interest on dramatic plays or he sets up a screen and runs a picture show. Does not the studio that issues coupons acknowledge by this very act that it can not maintain itself at regular prices? Is not the coupon scheme a sure road not to the \$2-a-seat patronage but to the 5c movie class of business of the photographic profession?

Think well, you who are urged to enter the coupon race. The solicitor says "*My work—85% of it will bring you orders.*" Do not forget that it is your negative, your prints and your salesmanship that must bring the orders if there are orders; the coupon salesman will be miles away at this time unloading grief upon another photographer. He will tell you that he will fill your studio with "the best people of the town"—always and only the best people, you know. Bear in mind this fact: he will sell to anyone who will buy; it means 50c or \$1 to him; it means his livelihood. And many, many times he will promise to the purchaser all sorts of extra concessions. I've known coupon salesmen to promise to include a framed 16 by 20 for good measure. Don't blame him too harshly; the photographer who thought so little of his work and his business as to send out such a man on such a basis more than half invited such treatment from the agent. Another enterprising coupon salesman showed me bluing paddles that he sold as

a side-line! Oh, what have we meant, we who have seriously chosen photography as our life-work, to sit idly by until such practise has become common!

As I write this, letters have come from the resident photographers of the state capital telling of the unequal struggle they are having with a travelling coupon photographer. The daily papers published a part of the speech of the coupon man, made before the city council, in which he makes eloquent comments as to what he will do with the capital city of this great state in the event of its interference with his coupon sales. The council took the matter under advisement and, while they are considering, coupons in great numbers are being sold and redeemed by this coupon studio.

The condition is serious. Shall photographs be regarded as art or as merchandise? If you want them considered as art, keep out of all coupon and cut-price plans. Keep your prices high and your ideals higher. Or shall photographs be tossed about as a piece of goods on the counter? Shall they be exchanged for a ridiculous printed slip sold here and there by any one to any one? Even some studios resort to the trading stamp or premium plan.

If we do not respect our own work, it is hardly likely the public will value it. If we say our work is worth only a dollar a dozen, the public will estimate that probably that valuation is quite high enough. If we want to make photographs at less than cost, there will always be numbers of bargain-hunters to fill our studios. But do we? We need not do it, you know, unless we choose. It is for us, the photographers, to say whether the next generation will hold our profession and our work in high esteem or in cheap repute. And if photography is to be considered as a real art, as really worth while, tomorrow is a day too late to begin discouraging coupon arrangements. Let us all help—and today is the time.

## SOME CINEMATOGRAPH HINTS

By A. LOCKETT



MATEUR operators, both of the cinematograph camera and the projector, continue to increase in number, and home displays are becoming fairly common. The inexperienced usually meet with certain difficulties, which in many cases give rise to bewilderment or disappointment. As such troubles can mostly be classified under about half a dozen well-defined headings, a few words on the subject may not be without interest, both to the amateur and to those who live by taking or showing motion pictures.

Some non-professional workers are very successful in selling motion picture films taken by themselves, but others, after a short trial, give up the attempt as an expensive failure. This is largely owing to their having omitted to grasp those essentials in which a good cinematograph film differs from an ordinary still photograph. The former should effectively depict movement, or it has missed its purpose. Yet many people seem to forget this, and select subjects in which there is but little motion, or at least none that is interesting. That is as bad a mistake as it would be to take stereographs of subjects showing no relief, or to copy black and white drawings on color plates.

Others, again, while getting plenty of animation in their films, manage to choose incidents of a purely local and ephemeral interest. These, of course, lose attraction in a few days at most, and are not worth the serious attention of film buyers. The sort of film really worth reproducing and capable of enduring a long run will always find ready purchasers.

The remaining secrets of successful motion picture photography are a rock-steady tripod, a first-class lens, a good intermittent movement, meter-timed exposures, and a well-chosen lighting, full of roundness and relief. Also, whatever the expert may do, the amateur is advised to select bright, spark-





TOXOPHILUS.  
A DECORATIVE STUDY.

EDWARD HENRY WESTON.

ling subjects, rather than those including many heavy or subdived parts.

There are numerous occasions, as when filming state processions or other events that draw large crowds, where it is impossible to find a suitable place at which the usual tripod can be set up. At such times, the simple accessory illustrated by Figure 1 will be found invaluable. It consists of a bracket formed by two stout boards A and B, screwed firmly together and strengthened by angle pieces. A third narrower piece of board C is held behind the bracket by two long winged nuts D and E, as shown, while at F is a hole for the camera screw. This appliance can readily be clamped by means of the

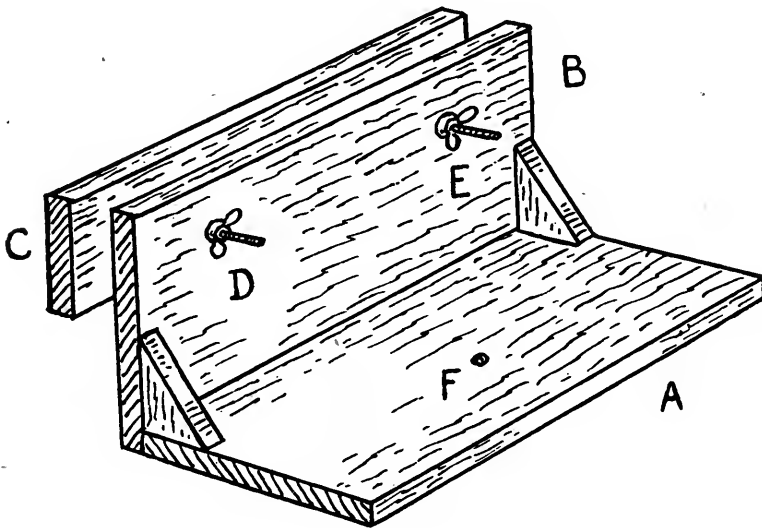

Figure 1.

back piece and nuts to railings or posts, projecting parts of grand stands, and similar vantage points. Figure 2, for instance, shows it secured by permission to some railings surmounting a conveniently placed wall, on which there is just room for the operator to stand. Needless to say, the bracket must be so strongly made as to be free from all shake or vibration, and the nuts must be screwed up tightly. The selected support should also be tested for solidity and firmness.

As might be expected, it is much more difficult to print a satisfactory positive film than to make a decent negative, and those who find it troublesome will be wise to entrust the printing to a trade firm.

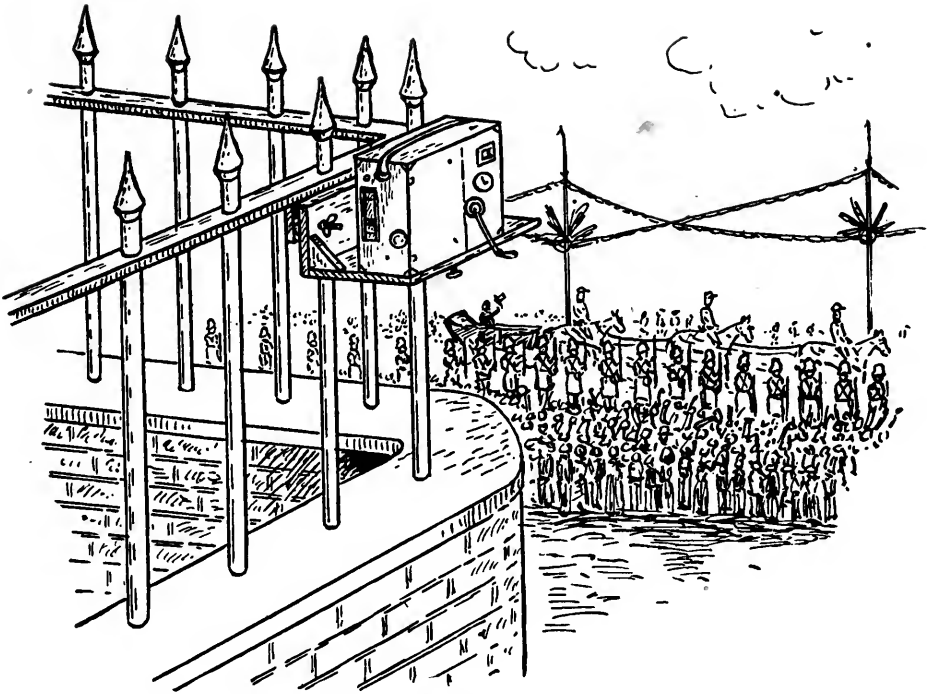

Figure 2.

From a commercial point of view there is little gained by producing the positive oneself, for purchasers of any standing very naturally prefer to have sole possession of the negative film, from which they are quite capable of judging the ultimate effect, and are not much interested in offers of positives. The latter, however, are sometimes saleable to managers of cinema halls when of special local attraction, as in the case of fire scenes, fêtes, election incidents, important weddings, etc.

With regard to exhibiting, undoubtedly the most common complaint is that of inadequately lighted pictures on the screen, and it is one by no means confined to the amateur, as those who have strained their eyes in some of the cheaper cinema theatres can testify. The most general cause is an ambitious attempt to get a larger projected image than is practicable with the illuminant used.

It is but little realized how very much greater is the degree of enlargement of a film picture as compared with a lantern slide enlarged to a similar diameter. Figure 3 will help to make this clearer. Suppose the optical lantern A is employed to project a slide having a mask  $2\frac{1}{4}$  in. by 3 in. on to the

screen B, the enlarged picture C measuring 2 ft. 3 in. by 3 ft., a magnification of twelve diameters. If, side by side with the lantern, we were to place a cinematograph D, with an objective of the same focus and having a gate aperture the full  $\frac{3}{4}$  in. by 1 in., the projected motion picture E, though also enlarged twelve diameters, would only measure 9 in. by 1 ft., or one-ninth the area of the lantern picture. It is, therefore, evident that, to get them both the same size on the screen, the film image will have to be enlarged nine times as much, which is commonly done by using a cinematograph objective of about one-third, or two-sevenths, the focal length of the lantern lens.

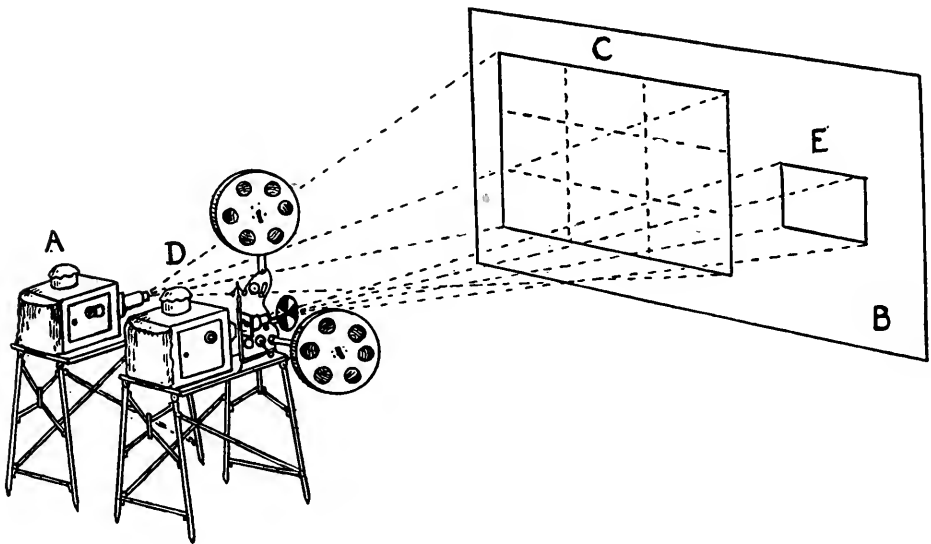

Figure 3

This means, as a little reflection will show, that to get as good an illumination with the cinema film as with the lantern slide nine times as much light will be needed, because the same light has to be spread over a space nine times the area. With a smaller film mask the difference is greater still. It must be remembered, also, that the whole of the light is available for the lantern, whereas in the ordinary type of cinematograph a portion is lost through the intermittent interposition of the shutter.

Yet the amateur cinematographer is perpetually ventilating his grievance, in very much the following style: "I have a lantern with a four-burner acetylene jet, and it gives a well-lit



THE ANCIENT PINE.

*Copyright by ANNE BRIGMAN.*

picture about six ft. diameter. I have lately bought a cinematograph attachment with lens, for use with the lantern, but cannot get a properly illuminated film picture more than two ft. wide. Why is this?" Should the last two paragraphs meet the eye of anyone thus perplexed, they will doubtless supply the solution of the mystery.

Obviously, a perfect screen surface is more indispensable for cinema projection than with the ordinary lantern. The happy-go-lucky pinned-up sheet, which lets half the light pass through, is of little use. A pure white, perfectly opaque screen is needed, or else one of the new silver-surfaced kind. A smooth well-whitewashed wall is very near perfection. Even in cinema halls, we far too often see a screen which is more of a dubious grey than a white, to the manifest detriment of the pictures, as well as probable waste of current, or of oxygen, in a vain endeavour to better matters.

A familiar law is much overlooked both by amateur and professional cinematographers—the law of inverse squares. According to this, light decreases as the square of the distance increases. Suppose we get a well-lit picture five ft. diameter, and that we want one ten ft. diameter, with equally good illumination. Many operators fancy they will merely need twice as much light, but are soon disillusioned. As demonstrated in Figure 4, if the distance is doubled to get a picture of twice the diameter, the same amount of light has to be spread over four times the former area, that is to say, an illuminant four times as powerful will be needed to get an equivalent lighting on the screen. A picture three times the diameter would require nine times as much light; one four times the diameter would call for sixteen times the illumination, and so on. This law applies also when a lens of shorter focus is used to obtain a bigger picture without taking the projector farther back.

Cinema operators often involuntarily cover a larger screen than their light justifies; simply because the hall or room is long and their objective is of short focus. The remedy, of course, is to obtain a longer focus objective, and thus get a smaller and better-lit picture in spite of the extra distance. There is no necessity to have such an enormous screen as one



WESTWARD HO!

THOMAS CARLYLE.

sometimes comes across. We do not see gigantic players on the real stage; why, then, turn them into sons and daughters of Anak on the simulated one?

Yet another cause of poorly-lit cinema pictures is the use of a cheap small-aperture objective. Economy in this direction is always bad policy, for the larger aperture of the better-grade objective will not only allow more light to pass, but the higher quality of the lens is sure to signify improved definition. Some of the less expensive home cinematographs and attachments will be found to give surprisingly better results with a change of objective.

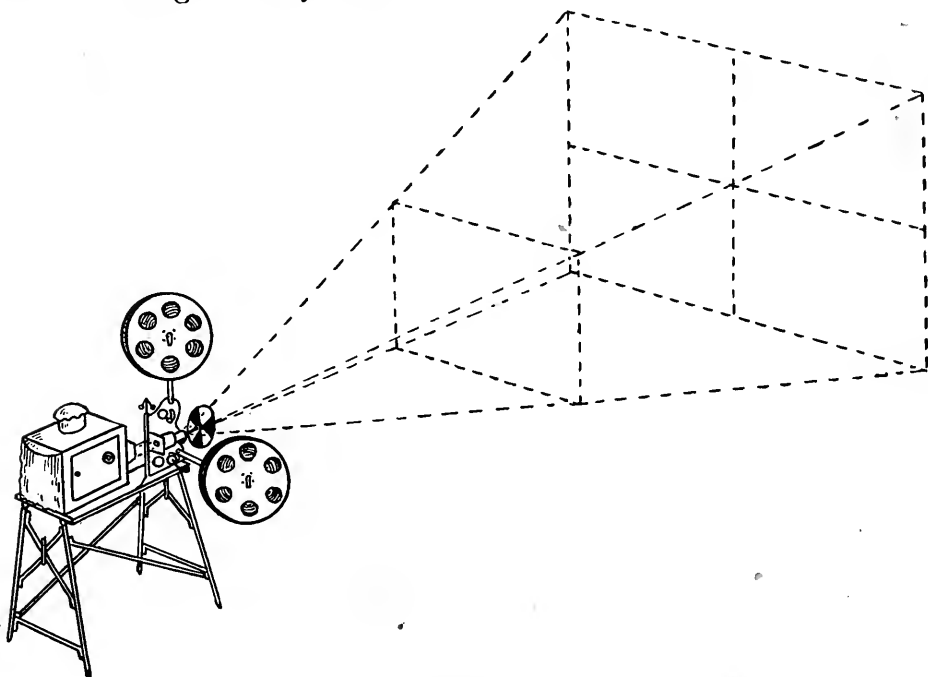

Figure 4.

A question frequently asked is, what candle-power will be needed for a cinema picture of a certain size? There seems to be a good deal of confusion on this point, and yet it depends on quite a simple rule. This is: for any two projected pictures of different diameter to be equally well lit, the respective candle-powers used should be proportional to the squares of the two diameters.

Thus it is only necessary to have a fixed standard, in order to obtain the candle-power needed in any given case. Suppose, as our standard, we say that a six ft. diameter picture at fifteen ft. distance calls for a light of 1,500 c.p., what amount





MOTHER AND SON.

BESSIE W. THOMAS.

of light will be needed for a picture nine ft. diameter at the same distance? The square of 6 is 36 and the square of 9 is 81, so the light required will be  $1500 \times 81 \div 36 = 3,375$  c.p., or, in round figures, 3,400 c.p. Since, roughly speaking, 10 amperes of continuous current give a light of from 1,000 to 1,200 c.p., a 30-ampere arc lamp will here be required. With alternating current one-fifth more amperage is needed, or 36 amperes.

Or, to give another example, suitable for the home cinematograph. Again taking 1,500 c.p. for a six ft. picture with a "throw" of fifteen ft. as our standard, what will be needed for a three-ft. picture? The square of 3 is 9 and the square of 6 is 36, so the light required will be  $1,500 \times 9 \div 36 = 375$  c.p., which is readily obtainable with a blow-through limelight jet.

The proposed standard of 1,500 c.p. for a six-ft. picture at fifteen ft. distance is certainly on the liberal side, and some operators would be well content with 1,000 c. p. Since, however, films differ in density, it is as well to err by excess rather than in deficiency.

It is sometimes stated that a longer "throw" does not affect the illumination provided the picture is kept the same size, but this is not correct, as light is lost by diffusion, and by obstruction where smoking is allowed. It is impossible to give an exact rule dealing with this point, but it will not be far wrong, for distances exceeding fifteen ft. and for pictures up to twelve ft. diameter, to allow 100 c.p. extra for each yard of increased distance.

"Flicker" is a defect of projected motion pictures which is still too frequent, even in theatres of some pretensions. It is a common mistake to confuse flicker with unsteadiness or jerkiness, an entirely different thing. Thus, the writer recollects an operator remarking, "Yes, this is a very tolerable machine, but it has too much flicker about it"; when, in fact, the projector was practically free from flicker and suffered solely from jerkiness of the intermittent mechanism.

Curiously enough, some of the very cheapest toy cinematographs show an entire absence of flicker; while some expensive theatre projectors exhibit the fault conspicuously. The



MARIE LEONHARD.

Wm. Shewell Ellis.



reason is simple. Flicker is entirely due to the shutter used to obscure the objective during the rapid change from one film picture to another, and in the cheapest grade of toy apparatus the shutter is omitted altogether. Thus, the juvenile exhibitor of lithographed motion films in a continuous band may have plenty of jerkiness and some "raininess," but he escapes the uneven alternations of light and darkness which give rise to flickering.

Projectors showing a disagreeable flicker will nearly always prove to be fitted with the old type of single-bladed shutter, forming a sector of from one-sixth to one-quarter of a circle. When using the latter, the period of light is obviously three times as long as the period of darkness, as shown at A in Figure 5. If we were deliberately trying to produce flicker it would scarcely be possible to find a more certain means than is provided by such inequality and abruptness.

The remedy is to equalize the intervals of light and darkness and also to shorten them, so that the increased speed renders their alternation imperceptible. The best way of doing this depends on the projector's ratio of change, or the time occupied in changing from one picture to another as compared with that during which the film is at rest in the gate. This can usually be arrived at by turning the handle of the unlighted projector very slowly, meanwhile holding, or getting someone else to hold, a visiting card steadily against one of the larger gear wheels. The film is then watched carefully in the gate, and, by listening to the clicks, the number of teeth is counted which pass during the period of change and also during that of rest. The second number divided by the first gives the ratio.

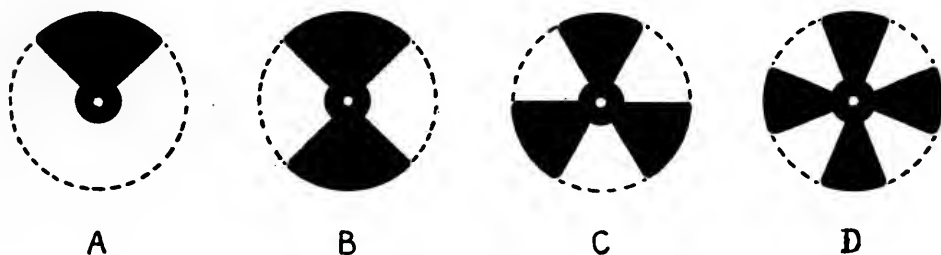

Figure 5.

Thus if, say, twenty-four clicks are heard between the end of one stoppage of the film and the beginning of another, but only eight clicks while the film is shifting, the ratio of change is as one to three. With this ratio, a shutter blade of one-quarter of a circle is used, therefore to balance light and darkness, and so to obviate flicker, two such blades may be employed, as at B (Figure 5). For a ratio of one to five the popular three-bladed shutter C is best, while for a ratio of one to seven a two-bladed shutter driven at twice the usual speed, or sometimes a four-bladed one D, may be used. In each of these cases, the extra blades necessarily reduce the light, but a virtually flickerless picture results.

It may be remarked, in conclusion, that, where the shutter is removable, it is quite easy to exchange an old-fashioned one, giving rise to flicker, for another of more up-to-date type. A worker of an experimental turn will find it very interesting to cut a shutter to suit his own requirements, in thin blackened metal, and much useful information will probably be gained thereby.



OUR CAPITOL.

CHAS. W. DOUTT.



ROWENA BLINCOE.

LOUIS FLECKENSTEIN.

## HALATION CORRECTED IN DEVELOPMENT

By GEORGE D. JOPSON

**D**O you remember that hurry call you had to photograph an interior and not a single double coated or non-halation plate in stock? Do you remember how you went to the job with misgivings, made the exposure, returned to your dark-room and developed out a beautiful lot of halation?

Since the editor has requested my annual contribution I have been searching for a subject, but each and every one that suggested itself has been rejected as too trite. At the eleventh hour, however, fate has favored me.

To commence with, I am not claiming originality for what follows, but I do claim that I used a grain of common-sense and put to use what I had at hand securing results beyond my expectation.

I received a hurried call from an architect to make eight interiors. Ill luck! Not one non-halation plate in stock. To save time and incidentally the job I "loaded up" with Stanley plates, intending to have the non-halation on hand in a day or two to repeat with. On my way a thought occurred to me. Two or three years ago a demonstrator told me of a metol hydro. formula for the correction of halation. There were only two things that I could remember about that formula. One was to double the time of the exposure, and the other, there was no carbonate of soda used. Here was an opportunity for an experiment. Surely I could not be any worse off so I took a chance. As I am wedded to both pyro and tank I decided to use those two expedients—my faithful standbys.

My regular developing stock solutions are as follows:

A—Water .....	16 ozs.
Meta-bisulphite of Potassium.....	70 grs.
Pyro .....	1 oz.
Bromide of Potassium.....	8 grs.



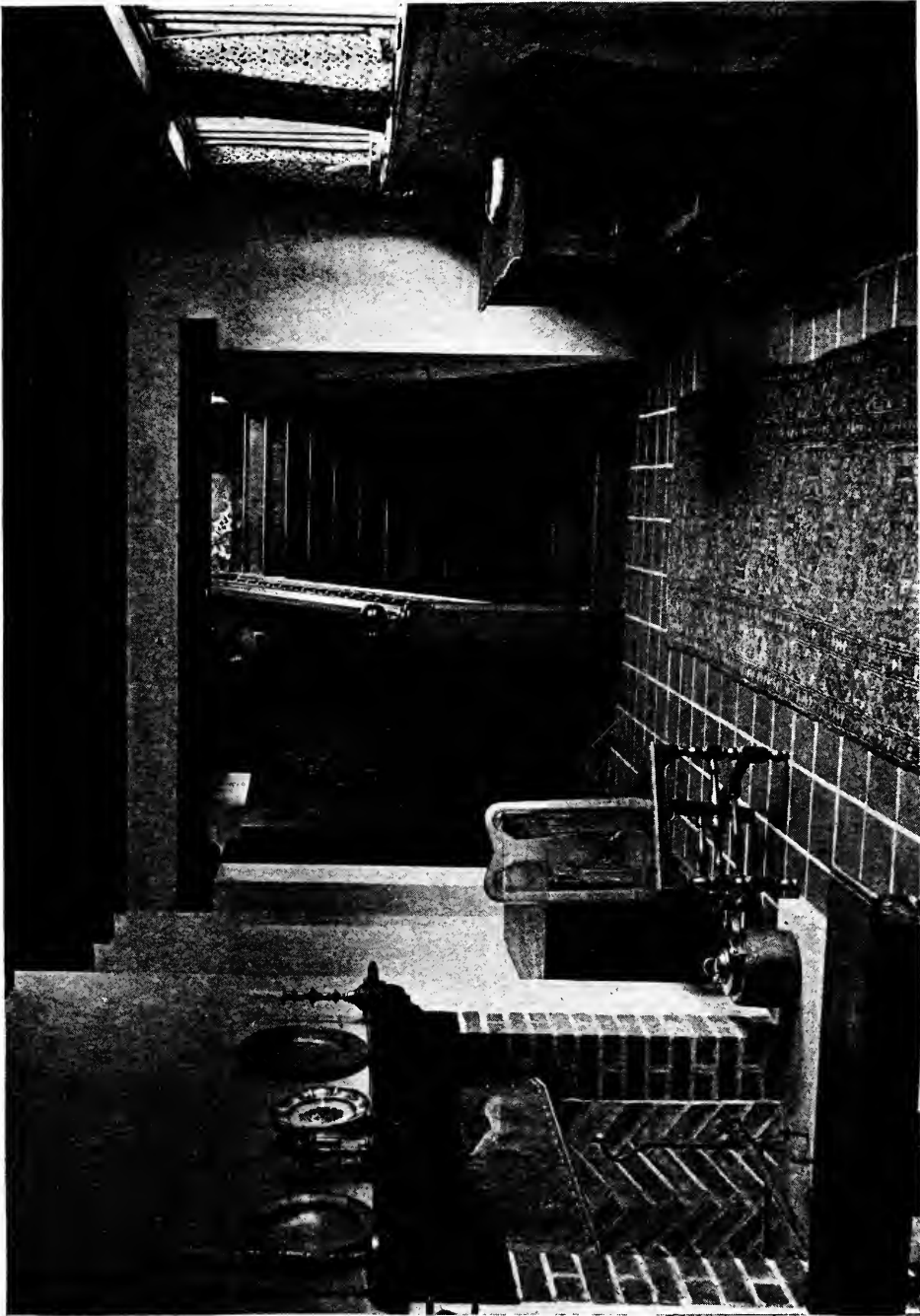

Figure 1.  
*Illustrating article "Halation corrected in development," by George D. Jopson.*

Mixed in order given.

B—Sulphite of Soda, 60° hydrometer test.

C—Carbonate of Soda, 40° hydrometer test.

To use, I mix 2½ ozs. of each, A, B & C in rotation and add 57 ozs. of water for 5 x 7 Eastman plate tank, and develop 20 minutes at 65°.

To obtain the non-halation result I modified the above to 2½ ozs. of A, 3 ozs. of B and only ½ oz. of C., mixed with 58 ozs. of water, temperature 60° and developed for 1½ hours in the tank. The tank was reversed every five minutes during the first half hour and every ten minutes during the remaining hour. When I opened the tank at the expiration of the hour and a half my surprise was only exceeded by my pleasure.

Look at Figure 1, a hard and trying subject. No halation around the windows, and in the darkest corners perfect detail—an even balance throughout the picture.

The exposure in this hall was fifteen minutes with a Bausch & Lomb Universal lens, at 32.

The living room, (Figure 2), the sun was just “hitting” the window. Data same as Figure 1, except exposure which was ten minutes.

If you are called out to make an interior and have no non-halation plates—why! just take your ordinary plates—double the exposure, modify your developer by increasing the sulphite, for the pyro will require it on account of the long development, and by cutting down the carbonate to almost nothing. Exercise patience. You will not care whether you have non-halation plates or not, for you can successfully correct halation in the development.



NATHAN R. GRAVES.



Figure 2.  
*Illustrating article "Halation corrected in development," by George D. Jopson.*

## EXPOSURE METERS

By J. W. EARLY



GENERAL motto for making an exposure is, "If in doubt, over-expose," which is a very good one, but the efficacy of a longer exposure than that indicated by a reliable exposure table or meter is doubtful. These tables and meters are calculated to give full shadow detail, and a longer exposure is useful only in exceptional cases. Some articles dealing with snap-shot work state that it is useless to make an exposure when the meter calls for anything less than  $1/25$  of a second, and recommend giving just a little more than it calls for. The experience of the writer is that the best results are usually obtained with an exposure of not more, and sometimes less, than that called for by the meter, and the negatives developed as will be explained a little later.

There are exceptions, however, when it is advisable to give more. One must use his judgment, for there are a number of conditions that tend to increase or decrease the exposure indicated by the meter. The photographic film or plate is more sensitive to some colors than others; a close view requires a longer exposure than a distant one; and the density of the shadows is of utmost importance, but as stated before, meters and tables allow for full shadow detail, and can be relied on to do so except where the shadows are unusually dark.

Too much exposure tends to give a flat negative, while too little gives a contrasty, and in many cases, worthless one. The instruction book coming with the Premo C Camera recommends an exposure of  $1/100$  of a second at U.S. 8 in bright sunlight. If a meter is used, such an exposure will never be indicated, in fact the meter will never show less than  $1/100$  at 4 at mid-day in summer, and usually more than this. On the other hand, exposure tables given in Photo Era and other photographic magazines give a still greater exposure than that shown by meters, and one using these tables can rely on ex-



THE COMING RACE.

Rudolf Eickemeyer.



cellent results, but care must be taken not to carry development too far.

In the case of the writer, developing has been done in a tank, but instead of using a whole powder as per directions, the powder has been divided into equal parts (by estimation), and only one part used at a time, the development being carried on for the same time as for the whole powder. One might think that the negatives would come out thin and under-developed, but instead they possess good density, perfect shadow detail, and make as good prints as could be desired. This might be partly attributable to the fact the temperature was taken before putting the film cage into the tank, and that the increase of temperature would reduce the correct time for development. In some cases, this raises the temperature as much as five degrees in hot weather, but it does not have much effect in winter.

In recent experiments made for the purpose of comparing this method of developing with the ordinary, for different exposures, two pictures of the same view were taken; one with the exposure as called for by the meter, which was developed for 20 minutes at 70 degrees (65 before putting in the cage and 70 after) with a half powder; the other underexposed three times by the meter, was developed for 19 minutes at 66 degrees with a whole powder. The main difference in looks between the two negatives was that the latter had the best looking clouds, but when printed, the former made the best print. The shadows in the under-exposed negative printed too dark and the print was too contrasty (except possibly for people liking contrasty pictures).

Other tests showed that to obtain a negative without undue contrast and with good sky tones, at least as much exposure as called for by the meter should be given, for development with a whole powder for the usual time, but if a half powder is used, excellent results are obtained by giving even a certain amount of under-exposure, and it is very seldom that the sky comes out white paper. However, the whole powder development is very useful in cases where a considerable amount of under-exposure is necessary as in the case of taking snapshots of persons in the shade (when one does not possess an anastigmat). This eliminates the "sun grins" which are very

objectionable, and if a point of view is taken so that the sky does not appear in the picture, and the majority of the picture is in the shade, a good soft picture is obtained. A place should be selected where the shade is very light.

While it is a good idea to give sufficient exposure, it is also well to know to what extent one can go beyond the meter in under-exposure and still expect good results. There are cases in which a picture may be wanted badly, and it may be better to get it at the expense of contrast and even possibly black or nearly black shadows, if not too numerous, than to let it go untaken. The shadows in the immediate foreground are the ruling factors that determine the extent to which one can under-expose. With no close shadows considerable under-exposure may be given and good results obtained by developing with a half powder, and when the light is uniform (all sunlight or all shadow) still further under-exposure may be given and the negatives developed with a whole powder.



ON THE SAVANNA RIVER.

F. W. HILL.





RUDOLF DÜHRKOOP.

## RIVER SCENERY—"CAPTURING" RUNNING WATER

By WILLIAM FINDLAY



ANY admirable photographs representing river scenes have, like the rich young man in the New Testament, one thing lacking. The pictures may be entitled "Scene on the River Merrimac" or "A View on the Mississippi," but, were they not so entitled, one might imagine the photograph represented a vista on some placid inland lake.

What does the picture lack, then? Simply that the idea of running water is not carried to the mind—it is not suggested. The latter word is considered the most important in photographic art.

It is quite understood, however, that in this particular branch difficulties are to be encountered, and the purpose of these words, and the photographs which they are written around, are to point them out and suggest remedies.

Many of the most beautiful river scenes are where the stream flows 'mid wooded banks. To "catch" the movement of the water a very short exposure is essential. The result is that the woodland portion of the composition is much under-exposed, and, if development is forced to get detail in this element, a negative that produces a "soot and whitewash" print is the result. The liquidity of the water is lost. Some semblance of the scene may be secured, but pictorially it is an absolute failure.

"What, then, am I to do?" asks the interested party.

This—Don't be too ambitious. Cut down the view. Concentrate on a relatively small spot, and make the most of it.

In "Foam-Flecked" (Figure 1) it was possible by ascending the bank of the river to secure a wide expanse, but it was thought that by concentrating attention on a small spot at the brink of the stream that a possible picture might be secured. A little further westward was a weir over which the water rushed majestically. Here it was more placid, though the



Figure 1.

FOAM FLECKED.

*Illustrating article "River Scenery—'Capturing' Running Water," by William Findlay.*

froth caused by the water's rapid journey was not entirely dissipated. Particular attention was paid to the beautiful curve along the bank, while the other accessories—the boat and the overhanging tree—were also considered. The first attempt was unsatisfactory. In fact before a picture to please was secured several six-mile runs on the cycle had to be made, and quite a number of plates exposed. But from each attempt a lesson was learned. It was found that a time exposure in a dull light gave a satisfactory rendering of the trees, but the suggestion of running water was lost. A bright light at noon was also unsatisfactory, but an attempt made five hours later with a "slanting" light (the sun was low in the heavens) with an exposure of  $1/50$ th of a second with the lens at F/8, gave the result here depicted.

The water in the middle distance may not convey strikingly to the mind the idea of movement, but the foam-flecked portion to the left does so to some extent and "controls" the whole expanse.

"Nature's Archway" (Figure 2) was secured near the same spot, the boat and the overhanging tree in "Foam-Flecked" (Figure 1) being incorporated in the composition. This is a river scene, but from its nature it might have been a lake scene. Running water had not in this case necessarily to be suggested. In fact, by the comparatively long exposure under the trees it was not possible to do so, though there is towards the right of the picture a faint semblance of movement on the water.

There is a charm in walking along the banks of a stream on the outlook for pictures. Likely ones are abundant on many of them and many a river unheralded as a beauty spot may yield fruit on a photographic pilgrimage. Get away from the beaten path, and on your journey keep continually looking for a "bonnie bittie," as the Scotch have it. Having found it, make an exposure or two. If unsatisfactory, try again, and persevere until success comes. You will strike the right note in time, and perhaps may be able to lay the flattering unction to your soul that you have discovered a new beauty spot in your neighborhood. Don't be a copyist. The pictorial photographer must be original.

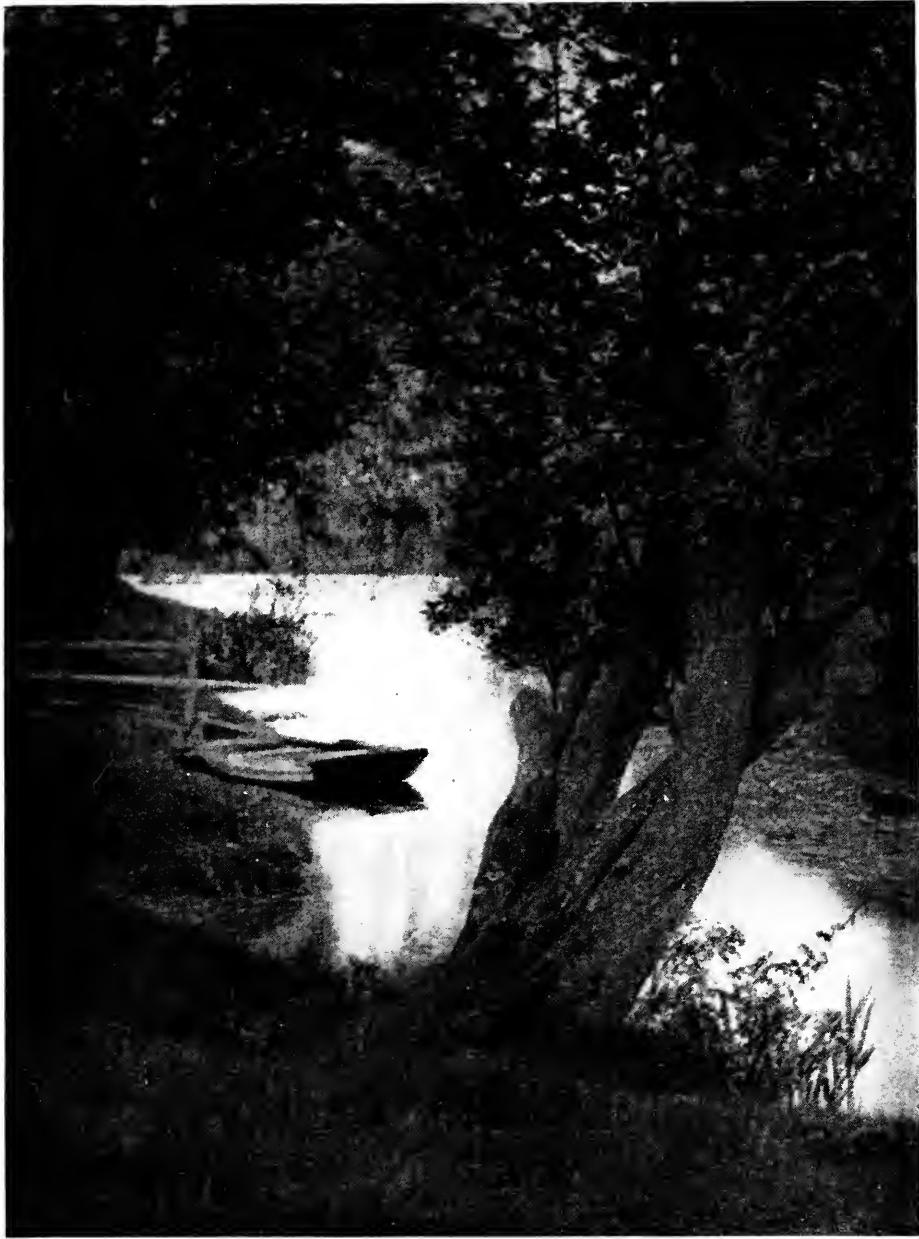

Figure 2.

NATURE'S ARCHWAY.

*Illustrating article "River Scenery—'Capturing' Running Water," by William Findlay.*

## A FEW WORDS ABOUT AUTOCHROMS

By DAVID J. SHEAHAN



SO much has already been written about autochroms, it would seem that there should be no more to say on the subject, yet from the number of questions that I have been asked of late, I am convinced that a few more hints about the manipulation of the screen plate, will not be out of place.

As the greatest trouble seems to be about exposure, it would be well to point out that infinitely more plates are destroyed by over-development than by over-exposure. Almost any plate that is not grossly over-exposed can be saved by sensible development if we will only understand that the longer the exposure the correspondingly shorter will be the development. In my own case, my best plates are those which have received from two to four times the exposure that the meter called for, but the time of development rarely exceeded two minutes.

In last year's "*Annual*" I recommended generous exposure and the use of a developer highly restrained with bromide, but since that time numerous experiments have convinced me that the same results can be obtained without the excessive use of bromide, by simply reducing the time of development. Now as to development, it is not absolutely necessary to start developing in the dark if one uses a good safe light, say three sheets of green and three of yellow "Virida" paper. The plate can be placed in the tray and development proceeded with so that the whole process can be watched closely, in fact after the first minute it is absolutely essential to examine the plate constantly so it will not be over-developed. The plate should be examined by holding it up to the light and looking through it. At first it will appear opaque but will gradually become opalescent. When it reaches this stage, just before becoming transparent, the plate is quickly rinsed in water and quickly transferred to the reversing bath. As stated before, great care must be taken to see that the plate is not developed too

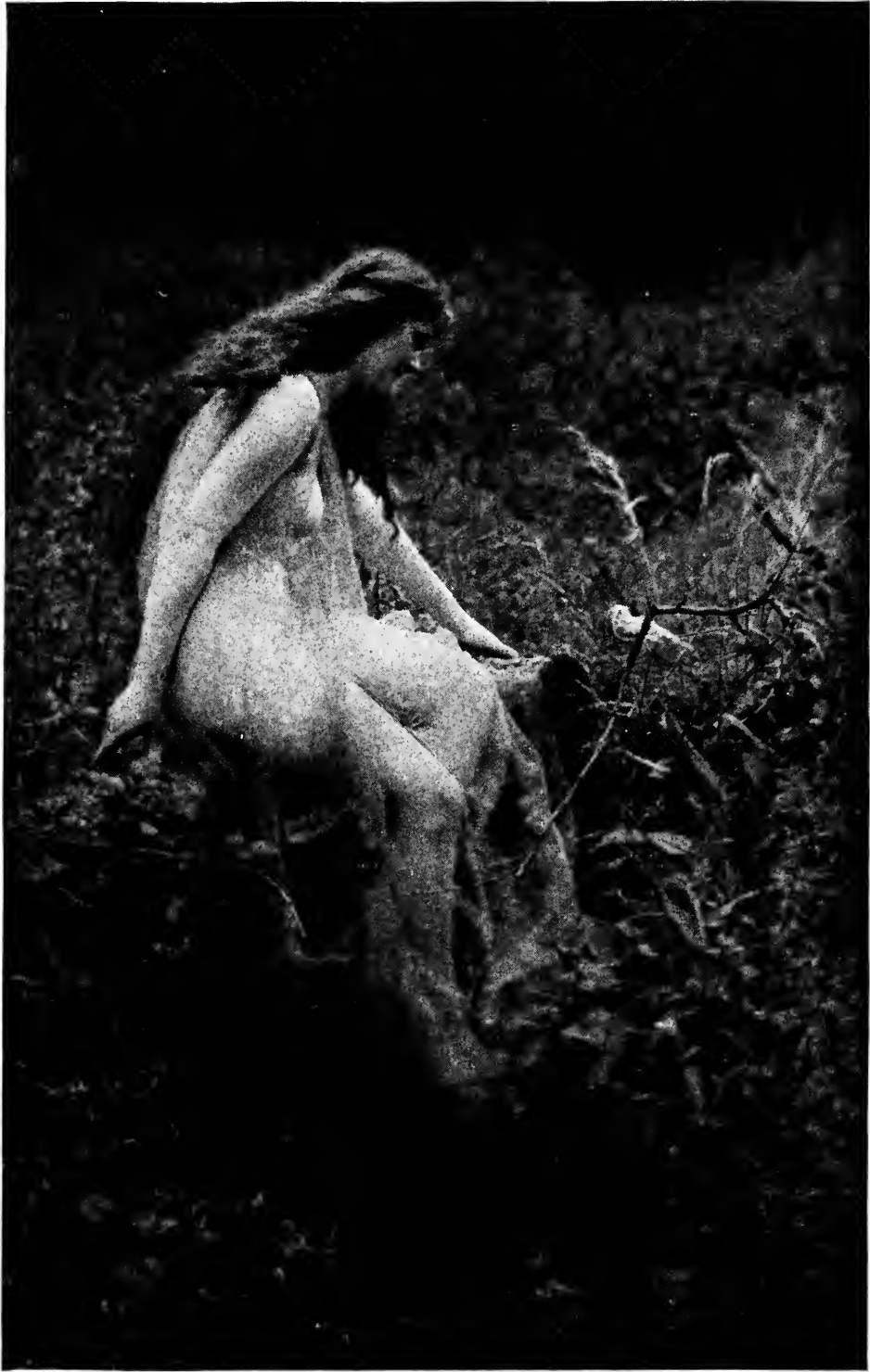

Kate Smith.





far. A few trials will show the point at which development must be stopped.

Of late, in fact since the war, scratches and green spots have noticeably increased on the autochrom, so consequently heroic methods must be taken to prevent their becoming too pronounced. Of course we cannot entirely obliterate them. It will be noticed that the slower the plate dries, the larger the green spots and scratches will become, so it stands to reason that the quicker the plate is dried the smaller the scratches and spots will be. Now, the remedy is obvious and unless handled carefully may prove disastrous. Wave the plate to and fro rather rapidly over a gas flame, and hold it at a distance of two or three feet from the same. Care must be taken that the autochrom does not become too warm. If it does the starch grains will melt and produce some of the most wonderful "Cubist Art" that one would wish to see. In this manner we may dry the plate in about five minutes, and the green spots will be no larger than when they came out of the developer.

When making sea views or snow scenes, it is an advantage to use a two time filter in addition to the autochrom filter. Of course this means doubling the exposure, but the extra filter helps considerably in cutting down the excessive blue.

There has been a good deal of comment on the pink skies which we often notice on over-exposed autochroms. Most of us seem to look on this as something detrimental, but our brothers of the brush seem to take a different view. It is rather a surprise to the autochrom worker when he first hears the artist rave over those wonderful pink skies and the beautiful blues in the shadows.

Another point that I would like to make strong is the use of the soft focus lens for pictorial effects on the autochrom. By use of this lens the most wonderful blendings of color can be obtained. Pictures can be made which resemble Corots or Turners, and the colors instead of being sharp look more as if they had been laid on with a painter's brush. It is this class of picture which appeals most to artists and go a long way towards showing them that the camera is just as legitimate a means of making pictures as is the painter's brush.

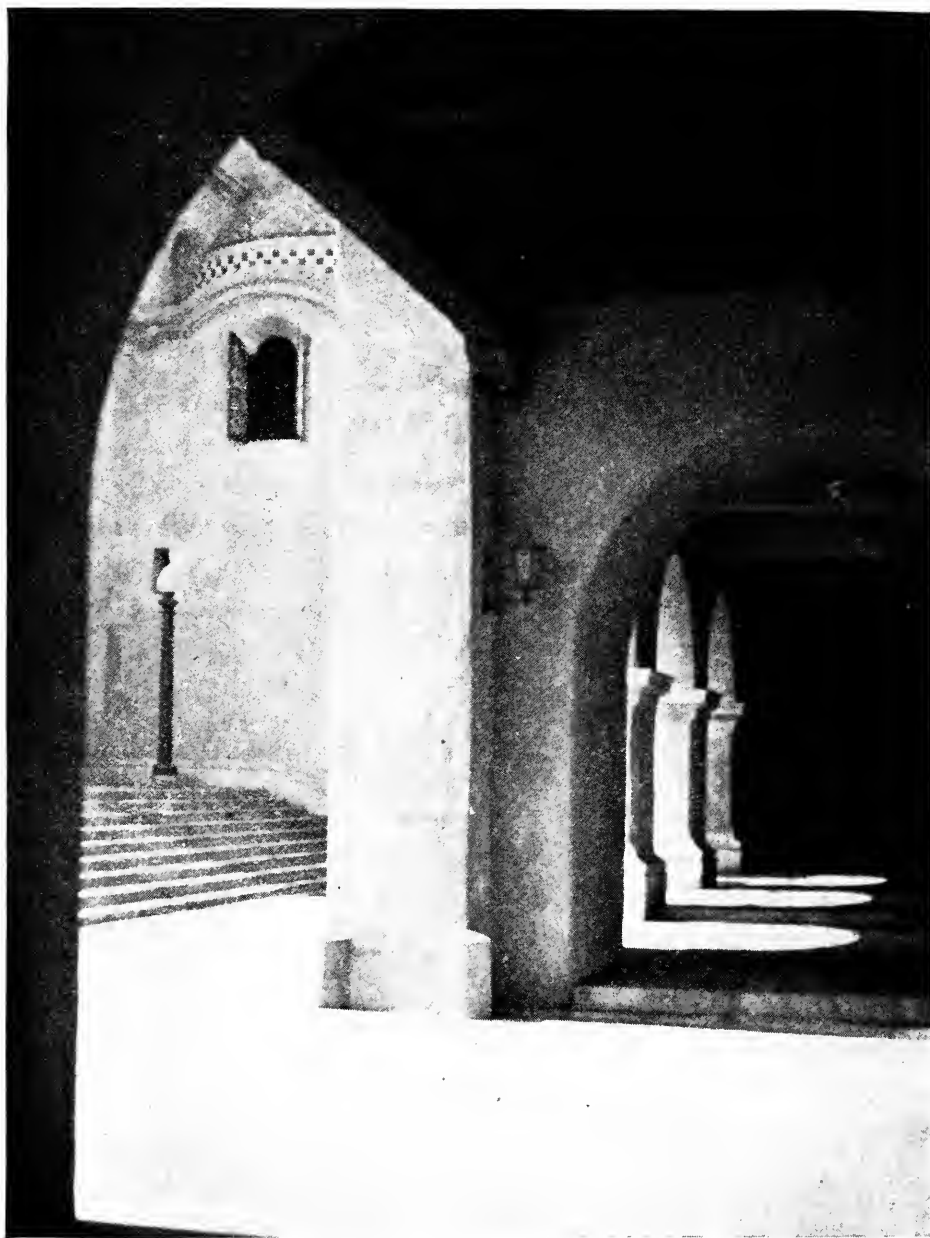

SAN DIEGO EXPOSITION.

*Print from enlarged negative from autochrome. Illustrating article "A Few Words About Autochroms," by David J. Sheahan. (Page 104.)*

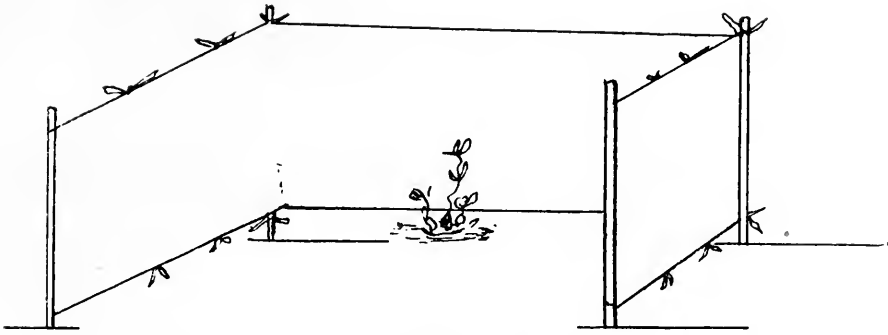

Figure 1.

*Illustrating article "Photographing Flowers In the Fields," by Stillman Taylor*

## PHOTOGRAPHING FLOWERS IN THE FIELDS

By STILLMAN TAYLOR



IN photographing flowers in the open the question of apparatus is of first importance. The camera need not be a very expensive one, but it should be of the plate type and provided with a bellows extension at least twice the focal length of the lens used with it. A three-fold extension camera will prove of great assistance, since it enables one to alter the size of the image on the screen without being continually obliged to shift the tripod about.

A reasonably short-focus lens is preferable. A moderate priced R.R. lens working at  $F/8$  is capable of doing fine work, but the flat field of a good modern anastigmat lens possesses certain advantages.

Orthochromatic, or color corrected plates, are really essential, and they should, of course, be used with a suitable color filter. For the average run of work a light yellow filter which increases the exposure not more than three times normal will prove the most satisfactory. The dark filters are less useful inasmuch as they over-correct, and the result is likely to prove less desirable and more untrue to the correct color values, than that of a good straight exposure. When photographing yellow and green colors as good, if not better, results are obtained by using the orthochromatic plates without the filter.

Exposure should be ample, and the best negatives are made by using a diluted developer. A negative of medium density also yields the most satisfactory print, hence the usual practice



Figure 2.

PIPSISSEWA TAKEN AGAINST WHITE BACKGROUND.

of making under-exposed and over-developed negatives must be avoided. A good flower negative should resemble a good portrait negative, rather than the average contrasty landscape negative. Softness of image is essential, and exposure should always be timed for the dark, and development must be stopped before the delicate gradations are lost and buried in the high lights. The usual rule is to secure detail in the shadows and let the high lights come out as they will. This will not do in flower work, for the high lights are of the most importance. Therefore aim to secure all possible gradation of detail in the high lights.

For many subjects a natural background may be chosen, but for the majority of subjects, a light background is needed to



Figure 3.

WILD AZALEA TAKEN AGAINST NATURAL BACKGROUND.

separate the specimen from its surroundings. As wind usually must be considered, a background which partially encloses the subject will be found very useful. A good portable background of this kind is shown in the sketch. (Figure 1.) Common unbleached cotton cloth makes a very satisfactory material. This is tacked on each end to a length of bamboo. Tapes are sewn at intervals along the top and bottom edges, so that the background may be smoothly and securely tied to the two loose bamboos at the back. This ground is easily and cheaply made, is very light in weight and conveniently rolled into a compact package and carried under the arm. It may be made in any desired size, and it is quickly set up by sticking the ends of the bamboo sticks in the ground.

## A SIMPLE MEANS OF PRODUCING PLATE MARKS ON MOUNTS

By JAMES N. DOOLITTLE



MOUNT to properly fulfill its functions as such should enhance the attractiveness of the print displayed upon it without being conspicuous in itself.

A painting surrounded by a heavy, elaborately carved frame, resplendent in karats of gold leaf, confuses the observer in wonder as to whether the artist is exhibiting the canvas or the frame.

Most of us either do or have resorted to the use of layers of paper of various shades beneath a print with the thought that an effect was produced complimentary to the picture, but have succeeded only in exhibiting our skill with the paste brush and leaving the original center of attraction marooned in a sea of cardboard.

I maintain that the mount of suitable weight which most closely matches the tone of the stock upon which the emulsion is coated is the most pleasing, and will be found to properly balance the print irrespective of the tone of the print or the process employed.

We will recall that engravers and etchers employ a sheet several inches wider on all sides than the impression, and this light margin with the plate mark is all the embellishment such work seems to need. Of course, it was no part of the original scheme with engravers that the plate mark should be noticeable but it is, nevertheless, attractive.

We do not recall having seen an etching surrounded by grey, brown, black or intermediate shades unless the impression was "pulled" upon that particular kind of paper.

This idea has its application to photographs and I have no more attractive means of preparing my pictures for exhibition than by printing upon a piece of paper considerably larger than the picture, or by mounting the print upon a card like-

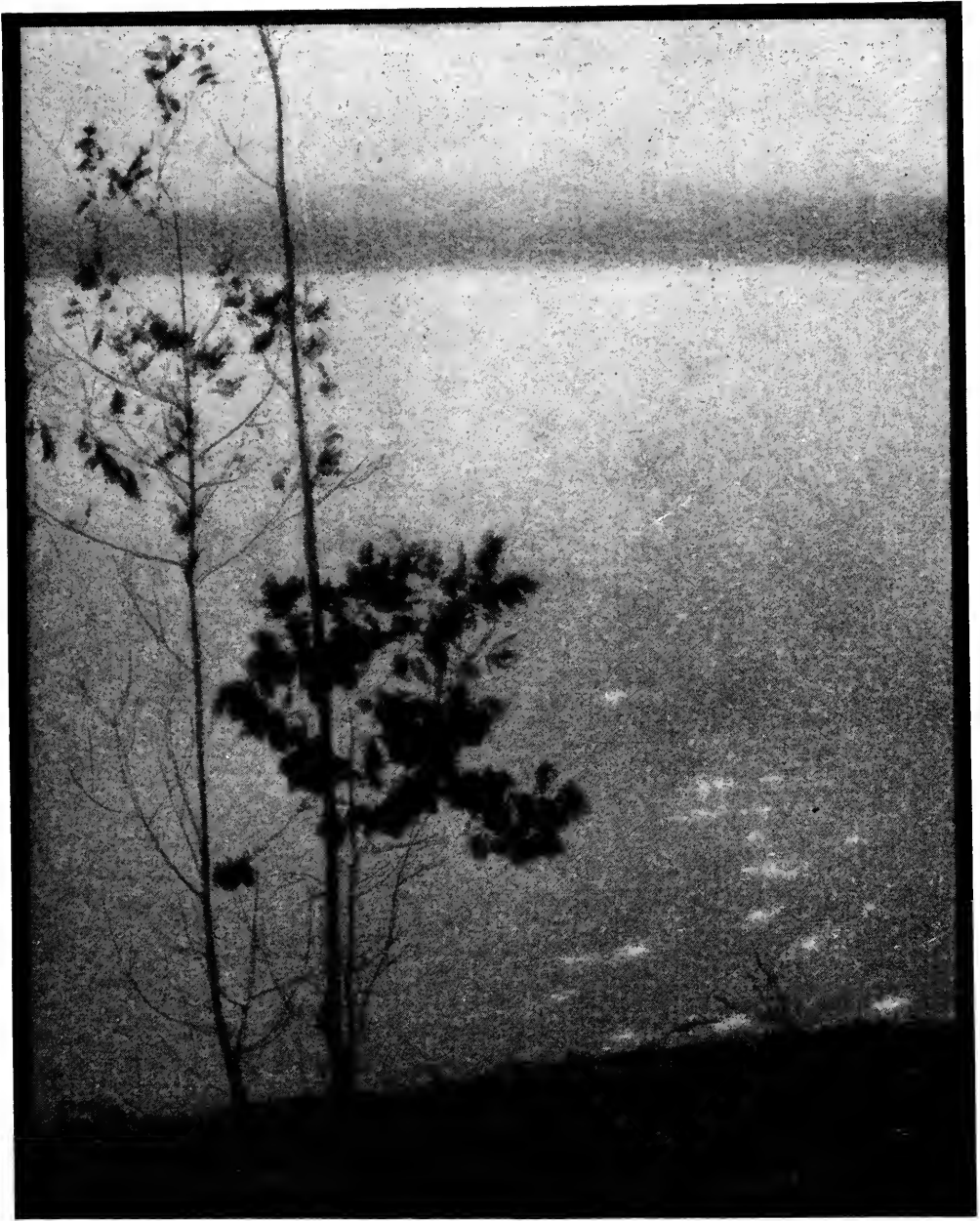

WHERE NATURE SMILES.

JAMES N. DOOLITTLE.

wise larger and as nearly as possible matching the stock of the print itself and then, by the means which I shall describe, plate mark the centre of the mount.

The necessary materials are few:

A sheet of about 10 ply cardboard the same size as the mount. Paste. An embossing tool such as the "Ingento." (This is a handle in the end of which is a  $\frac{1}{2}$  inch steel ball which revolves freely) or a short piece of hardwood with a perfectly rounded end.

The procedure is simple: Take the sheet of 10 ply cardboard, the same size as your mount, and paste upon it about  $\frac{1}{2}$  inch above the center, a piece of 4 ply card slightly larger than the print. This constitutes a form upon which the embossing is done.

With the face of the mount in contact with this form lay them together upon a smooth surface and pass the embossing tool over the back of the mount, with slight pressure, following the outline of the raised portion of the form.

Turn over the mount and observe the plate-sunk effect.

Attach the print in the centre of the depression thus formed and the operation is complete.

I have found 4 ply stock works most successfully and is of sufficient weight to properly support the print.



O. K. VOLKMAN.



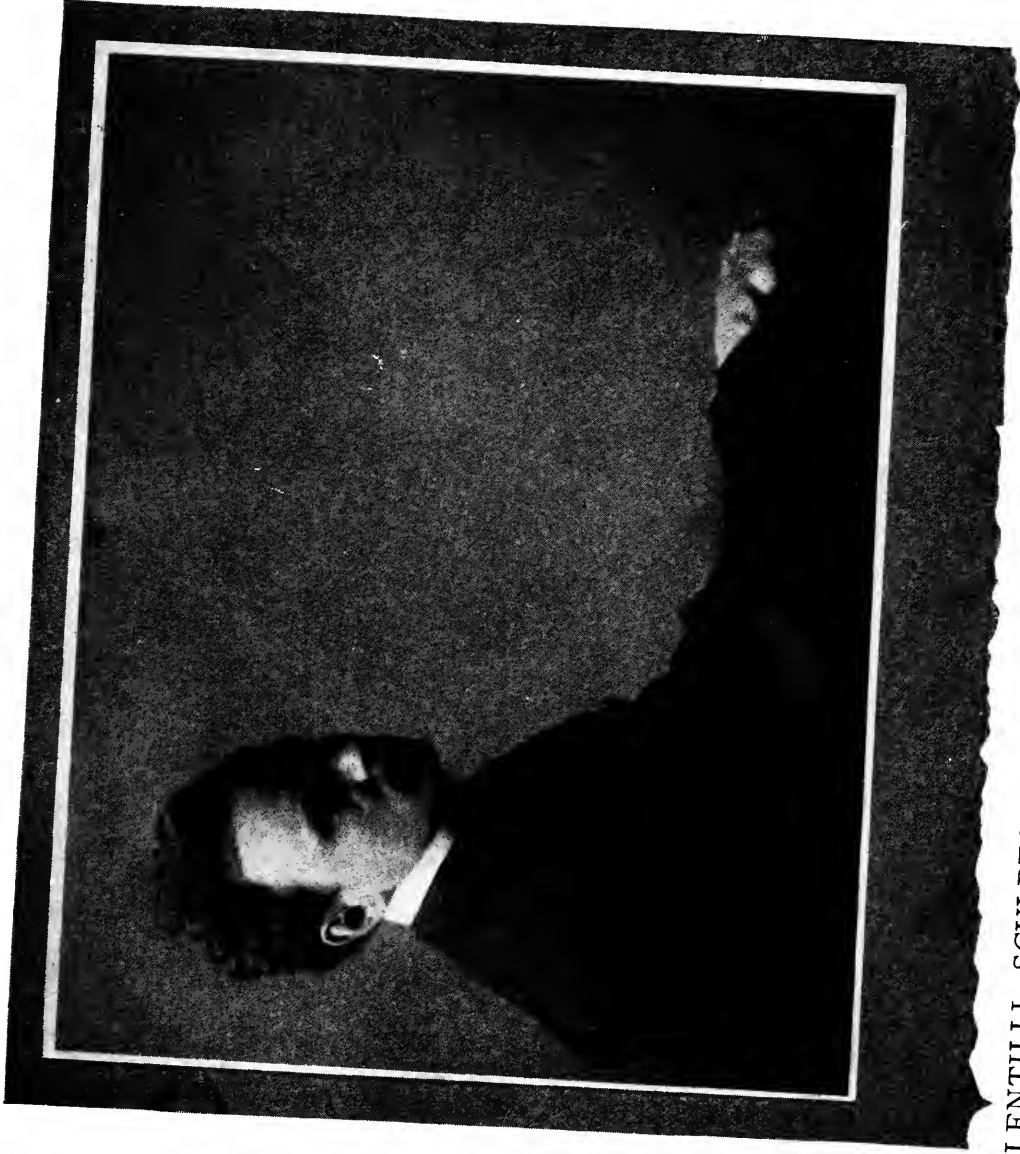

LENTILLI—SCULPTOR.

G. W. HARTING.

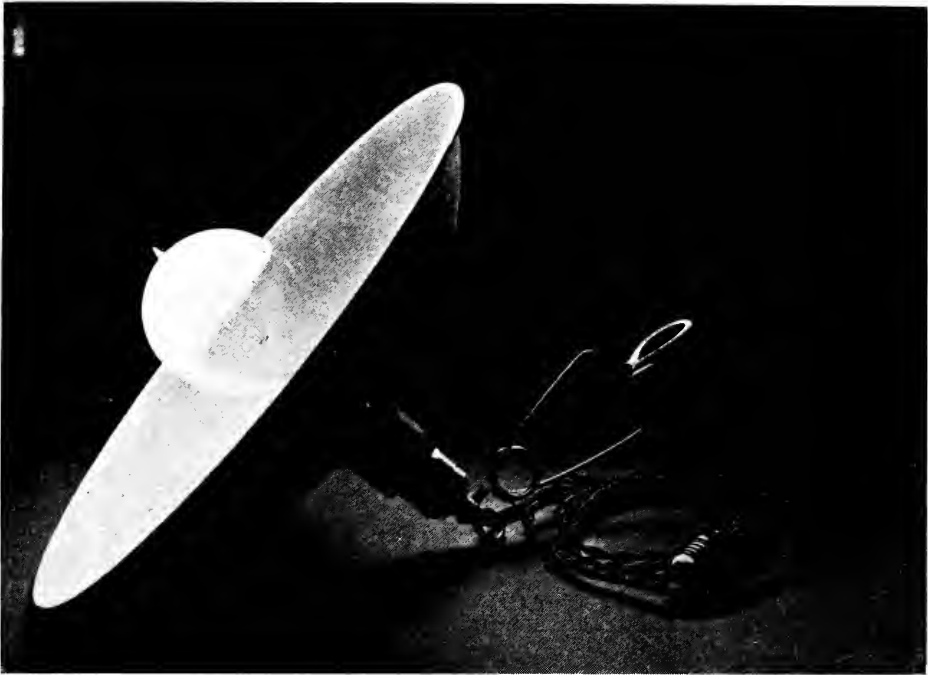

Figure 1.

*Illustrating article "Home Portraiture with Nitrogen Mazda Lamp and Reflector,"  
by W. W. Morey.*

## HOME PORTRAITURE WITH NITROGEN MAZDA LAMP AND REFLECTOR

By W. W. MOREY



AN article published in the 1916 American Annual of Photography on the Nitrogen Mazda light, contributed by Mr. E. J. Wall, F. R. P. S., led me to experiment with this light in connection with amateur photography, resulting in the assembling of the apparatus herewith illustrated (Figure 1).

Many times I have desired to take photographs at night, and on dark days, or in dark parts of the house where the background was suitable but the light was not, and these are some of the limitations all amateurs are at times compelled to meet. A suitable artificial light has been designed for professionals costing from \$18.00 upward, but that is more than the average amateur cares to pay.



Enlargement from  $6\frac{1}{2} \times 9$  cm. negative.

Figure 2.

*Illustrating article "Home Portraiture with Nitrogen Mazda Lamp and Reflector,"  
by W. W. Morey.*

The parts necessary to make up the light illustrated, and their cost, are as follows:

15 inch Porcelain Enameled Shade.....	\$ .75
200 watt Nitrogen Mazda Lamp (half frosted)	2.07
Keyless Socket .....	.10
Eye to fit Socket.....	.05
Spring Clamp .....	.10
12 feet Wire Cord .....	.18
Plug Connection .....	.10
	<hr/>
	\$3.35

There are many different ways of making this up, and a more powerful lamp could be used, or a cluster of three 75-watt lamps could be used with a still larger shade. The shade should be as light as possible, as I find the clamp holds more securely when attached to the back of a chair or shelf. The eye which screws into socket holding on the clamp is very useful when desired to suspend light from ceiling by means of a hook.

The portrait (Figure 2) was taken with one second exposure and with light five feet from subject. An exposure of from one to five seconds is correct, depending on distance of light from subject.

Panchromatic plates are highly satisfactory for photography by artificial light and are better suited than a high speed plate, I believe.

Pyro-metol works very well for development of artificial light exposures, bringing out all details which are sometimes lost in the shadows when using other less energetic formulæ.

The ideas herein presented can be improved upon in many respects, and very artistic lighting effects may be secured by anyone experimenting with this method of lighting, either by itself or as an aid to daylight, permitting the arrangement of the source of light from any angle or point one may choose.

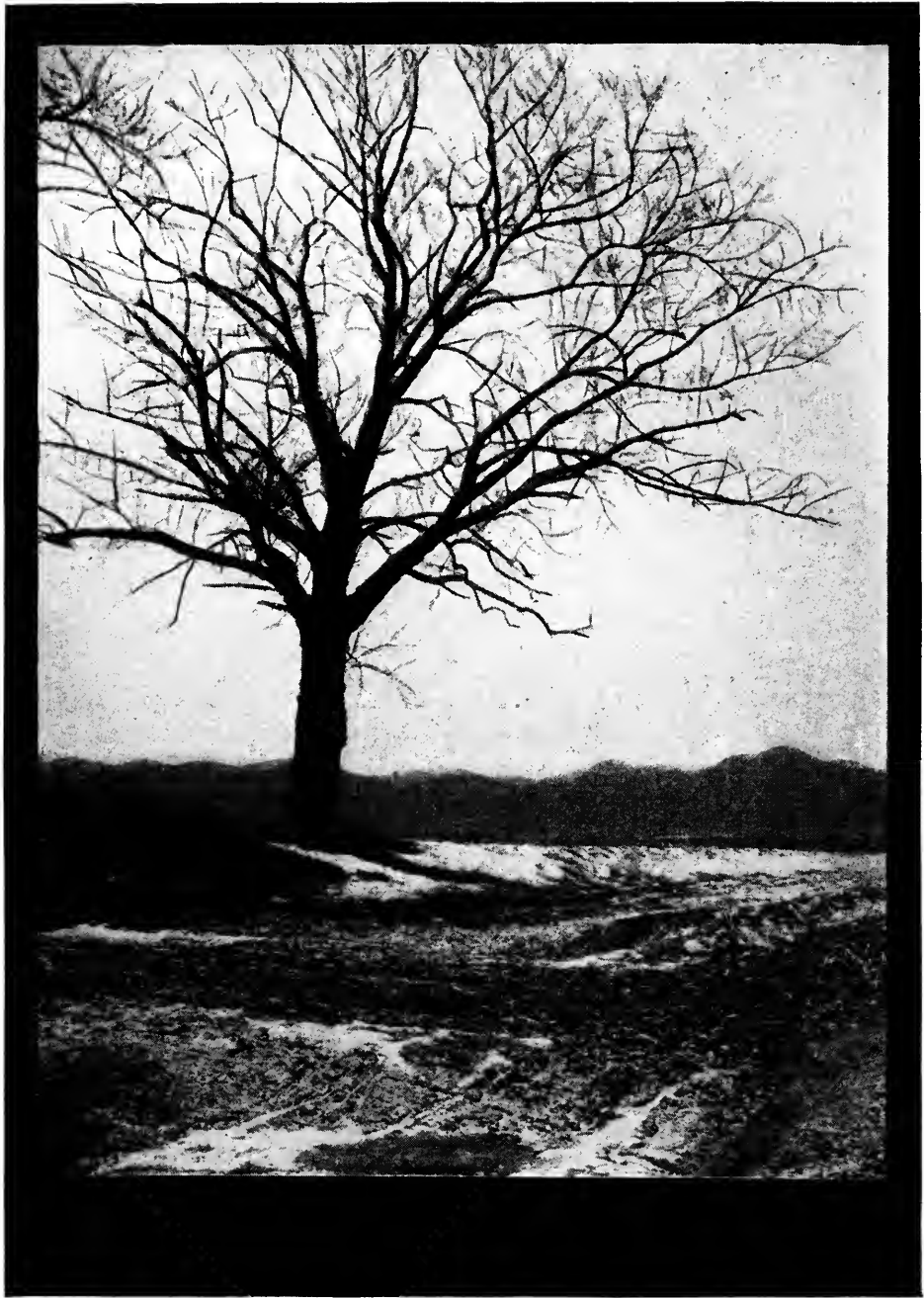

BEGINNING OF SPRING.

G. W. HARTING.

## THE SELECTION OF A NEW CAMERA

By BAYARD BREESE SNOWDEN



PROBABLY a large proportion of the cameras used by amateur photographers do not fit the persons to whom they belong. It is the easiest thing in the world for the inexperienced to buy something other than what he wants. A few points on camera selection may therefore be of interest.

One broad principle, now generally recognized, is this: The expensive camera, with special lens and shutter equipment, is for the person with technical knowledge, who can appreciate and utilize the fine points of a high-grade tool. A novice will have better success with a simpler and cheaper equipment. I know a man who bought a special 3A film camera a couple of years ago, paying for it about sixty dollars. Yesterday he returned from the beach with a lot of exposed film. He said he had given all the pictures  $1/100$ th with the diaphragm closed to the smallest possible opening— $F/32$ . He had stopped 'way down, he said, because the lens was a very fast one! This is a fair example of the misplaced camera. Such a person will get far better results with a three-dollar Brownie.

How about the person who knows very little about photography but means to learn? Supposing he has the money in his pocket, should he buy as high-priced a camera as he can afford?

The general answer to this question is yes, but I believe that in most cases it should be no. If a person knows little about photography, he is not likely to know what type of high-priced instrument will best meet his needs when he has become more or less expert. When he reaches that stage he may want a reflecting camera, or a view camera, or a high-grade post-card camera, or a miniature camera, or any one of several other types, and it will be small comfort to him to have a fine post-

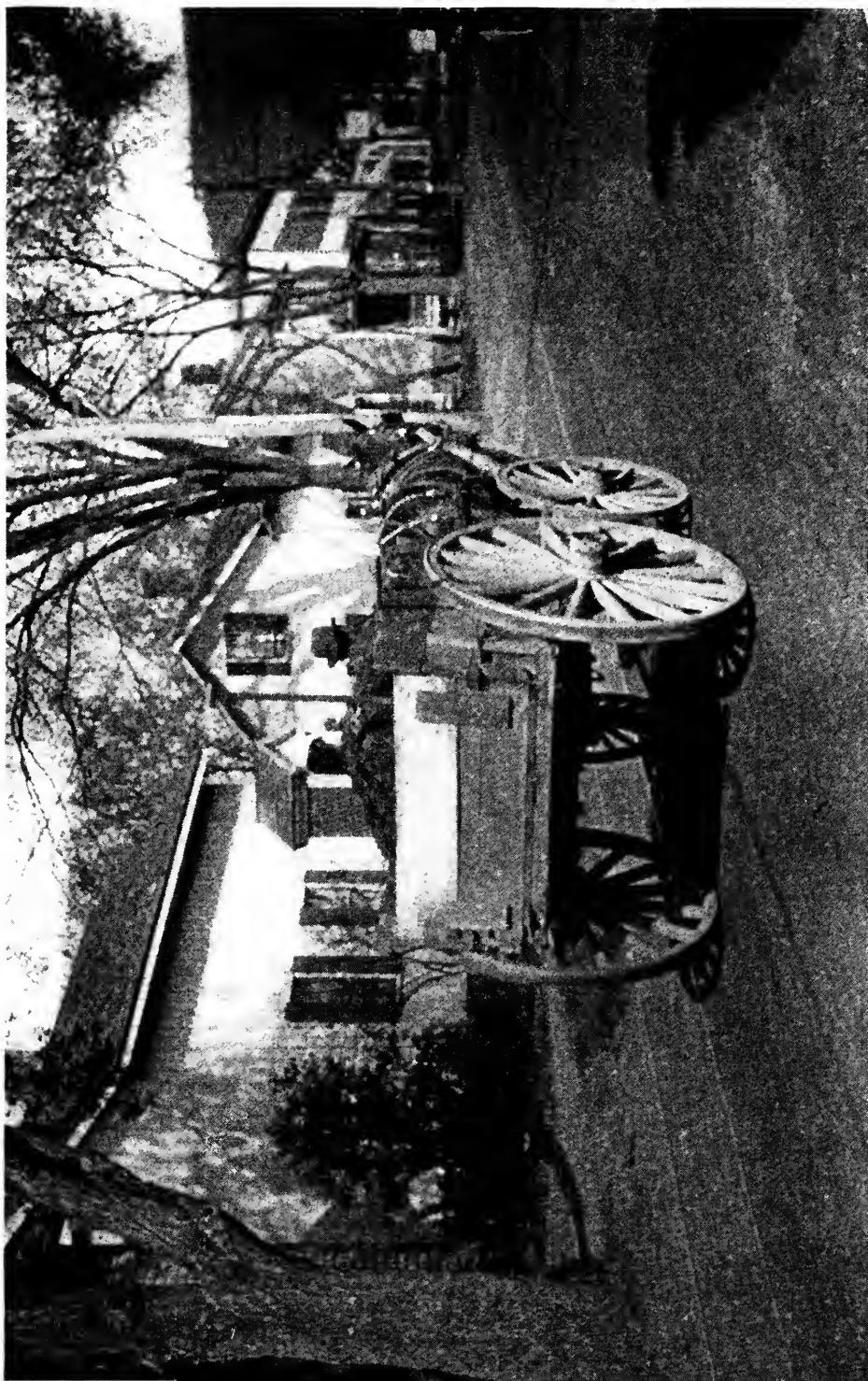

SPRING SUNSHINE.

Figure 2.

*Illustrating article "The Selection of a New Camera," by Bayard Breese Snornden.*

card camera if what he really wants is a first-class five by seven view. The purchase of new equipment should not be made by the inexperienced without this thought in mind.

Assuming, however, that a person is fairly well qualified to pass judgment on the virtues of a good instrument, what considerations should he have chiefly in mind?

The first consideration should be that of practical utility. If he fancies a reflecting camera he should ask himself to what extent he will wish to make speed pictures or indoor snapshots of the children, and whether, when the first enthusiasm has worn off, he will feel very much like carting around a big and somewhat heavy instrument of this type. If he fancies a view camera, because with it he can make fine large pictures, he should ask himself whether his way of life is going to be such that he will find it convenient to use. If he fancies a miniature camera which he can carry around in his pocket constantly, he should consider that the use of a miniature camera makes enlarging a necessity, and that enlarging, though not especially difficult, requires more time and energy than contact printing. And so on. A camera should be purchased not because admirable work may be produced with it, but because it is going to fit in with the amateur's natural habits and way of life.

There is still another consideration which should weigh with the prospective purchaser. If one expects his interest in photography to increase as time goes on, he should not try to combine too many virtues in the camera which he buys, but rather to look at it as one of several instruments which he will ultimately own. For example, suppose one fancies a 5 x 7 view camera and a  $3\frac{1}{4} \times 4\frac{1}{4}$  film camera. It would be very poor policy to split the difference and purchase a folding camera of the 4 x 5 size. In a very short time the 4 x 5 would be too small for one purpose and too big for the other. A much better plan in this case would be to choose between the small film camera and the view, getting the one which best suits present needs and leaving the other for purchase later as means permit. As a matter of fact, an advanced worker owns





AFTER THE BATTLE WITH THE STORM KING.

Edgar A. Cohen.



not one camera but a string of cameras, and if his purchases have been judicious each exactly fills the bill for a certain class of work.

The final suggestion seems so obvious that it is made with some hesitation, but it may be of assistance to a beginner here and there. Pictures as they appear in the various magazines are seldom a safe guide for determining what size camera is to be preferred. The two pictures accompanying this article (Figures 1 and 2), for example, might seem to indicate the value of working in the larger sizes, but they don't indicate anything of the sort. The reproductions in both cases are from enlargements, the original negatives being small and only parts of them used. On the other hand, the uninitiated will find in the magazines and indeed in this book many small pictures reproduced from contact prints as large as 8 x 10.



Figure 1.

AUTUMN.

*Illustrating article "The Selection of a New Camera," by Bayard Breeze Snowden.*

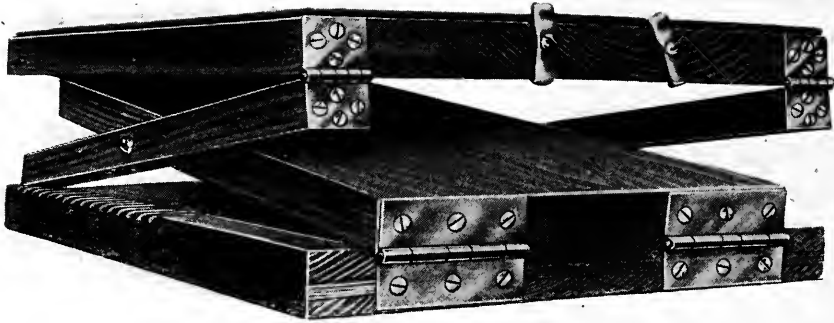

Figure 1.

*Illustrating article "An Adjustable Copying Stand," by Henry F. Raess.*

## AN ADJUSTABLE COPYING STAND

By HENRY F. RAESS



ONE of the most useful pieces of apparatus in the possession of the photographic department of the New York Herald is a copying stand designed by Russell T. Phillips, a member of the staff, and constructed in the carpenter shop. As several dozen pictures have to be copied every day its convenience is greatly appreciated. It was mainly intended to hold a 5 x 7 camera but, of course, it will also hold larger as well as smaller cameras.

The size given here need not be adhered to and may be changed to suit conditions, but after two years of constant use we have found this quite satisfactory. When closed it measures 10 inches wide, 14½ inches long and 2¾ inches high, but when fully extended the height is 15 inches; the other dimensions do not change. The stand consists of three boards and two legs. (Figure 1.) The boards are white pine 7⁄8 inch thick, the upper and lower boards are 10 x 14½ inches and the middle board is 8 x 14½ inches. In order to prevent warping as far as possible the ends of the boards have been grooved and a cleat put in. The legs are made of ash (as a



RUDOLF DÜHRKOOP.

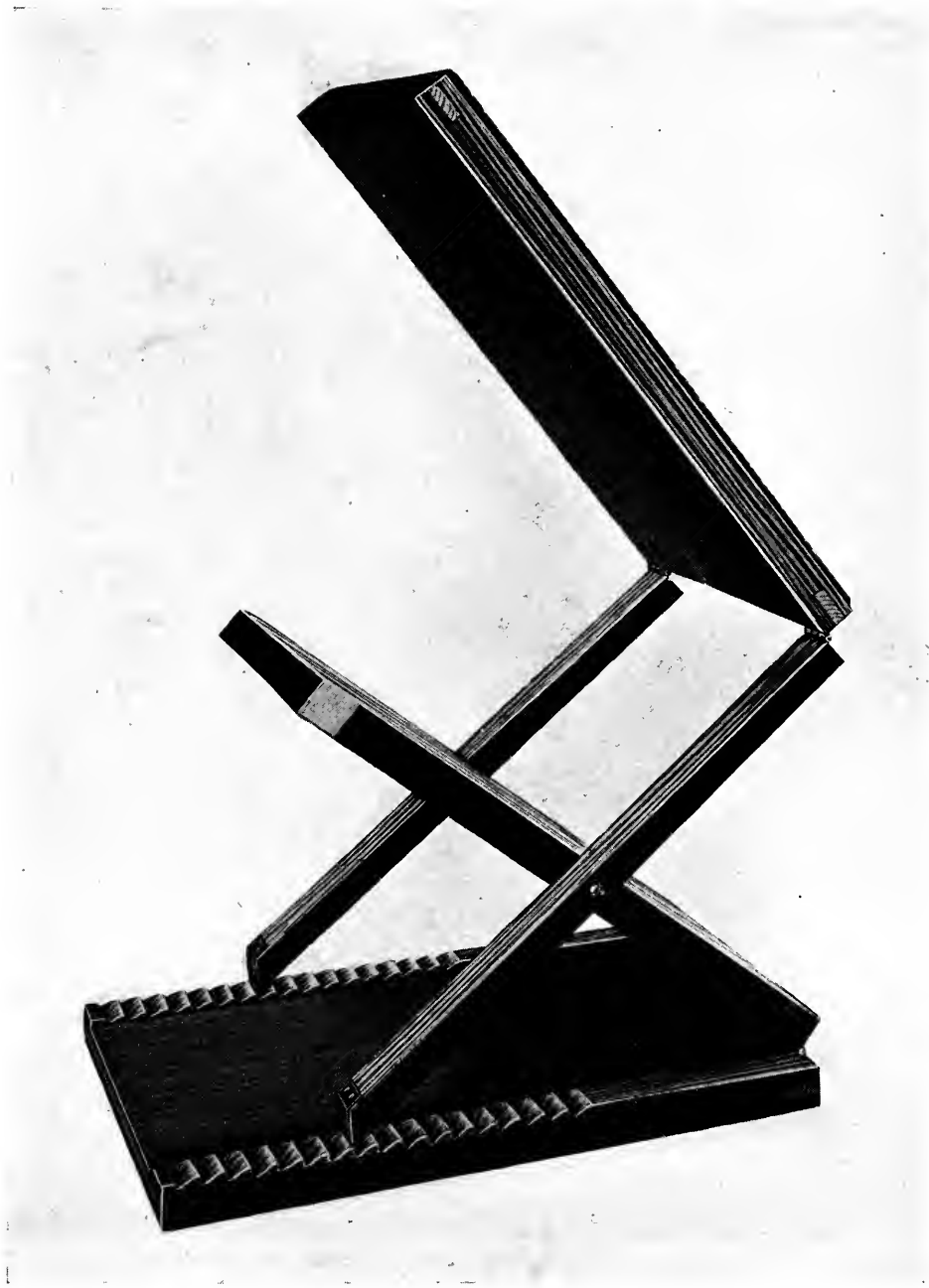

Figure 2.

*Illustrating article "An Adjustable Copying Stand," by Henry F. Raess.*

hard wood is preferable for this). They measure  $1 \times \frac{3}{4} \times 14$  inches. The lower ends of the two legs are cut at a bevel, the sharp edges catching between the teeth of the rack and holding the platform for the camera at the desired height. (Figure 2.) The upper ends of the legs are fastened at the front to the top board with hinges and the center board is also fastened with hinges, but to the lower board in front.

The particular advantage possessed by this stand is that the top board and the base board are always parallel, that is, the camera is always level if the stand is on a level surface. (Figure 3.)



Figure 3.

*Illustrating article "An Adjustable Copying Stand," by Henry F. Raess.*

## LABORATORY NOTES

By MARCUS G. LOVELACE

Lovelace Research Laboratory



IN preparing an article for the *Annual* this year the most natural thing to do would seem to be to prepare an article on the various substitutes for the old familiar things that we used to be able to purchase without neglecting our family by so doing. There has been enough to go around in the chemical line and that is about all, but the prospects seem brighter for the next year, and it may be that the undersea liners will solve the problem and that we will have metol—or at least monomethyl-para-amidophenol sulphate—at a price where we can use it as of yore.

Many photographers labor under the impression that metol cannot be made in this country. Metol can be made, and is made, but not on a sufficiently large basis or at such a price that it solves the problem by any means. To establish a chemical works that would supply any quantity of metol means the outlay of a good deal of money—the ending of the war would mean competition with the European manufacturer and the American manufacturer naturally is not taking any chances. We have been informed, however, that one of the largest works in this country expects to be able to supply metol under another name in a few months so that the supply is not likely to vanish from the market.

Working to find a cheap and satisfactory substitute for metol in the form of some altered developer which was at hand, the possibility of the use of some of the caustic alkalies, instead of the alkaline carbonates, was tried, as being of greater activity. These hydrates, sodium, lithium and potassium, respectively, have never been used to any great extent partly on account of the action on the skin—and partly because of a certain softening of the film, as well as a prejudice against strong alkalies. They are generally regarded by the non-chemist as simply stronger carbonates (that is stronger alkalies





THE END OF THE VOYAGE.

C. E. WAKEFORD.

than the carbonates) while in their action they bear no resemblance to the carbonates.

Dr. Andresen first discovered their peculiar action, and the well known developer Rodinal is the best known application of the hydroxides to developers. Von Hubl in "Die Entwicklung der photographischen Bromsilber Gelatinplatte bei zwiefelhaft richtiger Exposition" has given the true explanation of this action in the developer at some length. The hydrogen in the hydroxyl groups of the phenol or naphthol developers can be replaced by potassium, sodium or lithium, whereas the alkaline carbonates simply make the solution alkaline without changing the nature of the developer. In other words, the hydrates or hydroxides form saltlike compounds which will develop even when nearly neutral, although they work better when they are slightly alkaline, while the carbonates form developers which must be alkaline in order to develop in an ordinary lifetime. These developers from the caustic alkalies are energetic, do not fog and can be diluted *ad libitum* without changing anything except time of development. Also they keep splendidly. I have worked out some formulæ which will probably be of interest, one of which, I think, is exceedingly valuable—i.e. the hydrochinon.

But to begin with—buy your chemicals of a supply house, but get them to get known brands. Eastman is as good as any—possibly a little cheaper for the same grade—and see that your chemicals are C.P. It is an outrage to have anything else, anyway. When one walks ten miles to get a picture and then has it spoiled by some of the terrible messes that are sold as photographic chemicals,—well, we've all done or will do it, and the state of mind is too well understood to make it necessary for me to say anything about it. Get Kodak chemicals and you'll not go wrong.

#### HYDROCHINON

Add 1 gram of Sodium bisulphite (dry) to 90 cc of water (distilled if you can get it). When dissolved add 2 grams hydrochinon. Now add 90 cc more of water, dissolve 4 grams anhydrous sodium sulphite and 2 grams potassium hydrate (in sticks purified with alcohol) or 1.5 gms. of sodium hydrate (in sticks as above). When dissolved add to the first



PEGGY WOOD.

John Wallace Gillies.



solution containing the hydrochinon and filter. The water is better hot than cold and better distilled than tap. When it is cold bottle with rubber stoppers, and have the bottles full. It will keep well and is a most satisfactory developer. It may need a little bromide when used with velox or cyko and sometimes does with bromide papers. When used with papers, it is best used about 1 part developer to 1 of water. For plates or films it may be diluted as necessary, but bear in mind that the image will appear very quickly and probably will require some little time to build up.

The following formula will be found very good for Hydrochinon without metol,

Water .....	850 cc
Hydrochinon .....	6.5 grams
Sodium Sulphite .....	30 grams
Sodium Carbonate .....	100 grams
Potassium Bromide (saturated solution)	
	20 to 30 drops

The image comes up immediately but time of development should be about one minute.

#### PYROCATECHIN

On the chance that some one may be in touch with a small stock of this excellent developer, I have worked out a formula for it. To 100 cc of hot water add 1 gm of sodium bisulphite, and when dissolved add 10 gms of pyrocatechin. In another beaker add 25 grams of sodium sulphite (anhydrous) and 10.5 gms potassium hydrate, to 100 cc of water, and when dissolved add to solution containing pyrocatechin—filter and bottle. This does not keep so well, but is the most energetic developer of all, the entire image appearing as soon as the developer sweeps over the plate or film. This should be used about 1 part to 2 of water for paper—for plates, films or bromide paper it may be diluted as seen fit. It is probably the best lantern slide developer known—in spite of the wearying repetition of the well-known statement re hydrochinon. Photographers tell themselves fairy tales like this until they believe them themselves.

#### PARA-AMIDOPHENOL.

I will give two formulæ for this—one in line with the others

and one which will give Rodinal: 100 cc of water as hot as the hand will bear or say 80 deg. C.—add 30 grams potassium metabisulphite C.P. When dissolved add 10 grams para-amidophenol. Stir well. In 50 cc of water dissolve 19 grams of potassium hydrate. Now add the solution of potassium hydrate to the solution of para-amidophenol very slowly, with constant stirring. A heavy precipitate will form, and the solution of potassium hydrate must be added until this just dissolves and disappears. Should it be found that the whole of the hydrate is added and there still remains a precipitate very small pieces of potassium hydrate should be added until it dissolves. Should it not be necessary to add the whole of the 50 cc of hydrate solution, the completed developer should be brought up to 150 cc with water. This can be used about the same as rodinal, although there is a slight difference.

The next formula gives a solution which can be used exactly as rodinal, and it may be substituted for it in any way. It is of the same strength and dilutions for rodinal or temperature tables will serve for the developer about to be given.

Water 1000 cc—para-amidophenol 20 grams—sodium sulphite (anhydrous) 150 grams—lithium hydrate 8 grams. Dissolve the sodium sulphite in about 800 cc of hot water, when dissolved add the para-amidophenol. Dissolve the lithium hydrate in about 100 cc of water and add to the first solution with constant stirring. A heavy precipitate will form, and the lithium solution should be added until this precipitate just dissolves. The bulk of the solution should be made up to 1000 cc and bottled. This is to all intents and purposes—Rodinal.

Should the given amount of lithium hydrate refuse to dissolve the precipitate first formed do not allow the bulk to go above 1000 cc, but add tiny pieces of lithium hydrate until solution takes place. Should the precipitate be dissolved when only part of this hydrate solution has been added, do not add the rest—but make up to 1000 cc with water.

#### PYRO.

Our old friend pyro if used with an excess of sodium sulphite and a little potassium *ferro-cyanide* (not ferri) will give excellent prints.



JOY.

*Copyright by Albert B. Street.*

The following formula will be found to give good results and is based on one given by the Ansco Co.

No. 1—Pyro .....	12 gms
Sodium Sulphite .....	80 grams
Potassium Ferrocyanide (not ferri).....	2 grams
Water .....	500 cc
No. 2—Sodium Hydrate .....	4 grams
Water .....	500 cc

Use one part No. 1 and one part No. 2 with water 2 parts, and 3 drops of saturated solution of Potassium Bromide to every 400 cc of developer. The potassium ferrocyanide takes up all the oxidation products and reduces staining to a minimum. The colour is very good and the developer may be used repeatedly without materially reducing its speed which is about one to one and a quarter minutes. This also gives very good prints for sepia toning. If diluted to half strength it gives softer results without changing the gradation too much.

#### FERROUS OXALATE.

Ferrous oxalate also makes a good developer for any paper and a formula may be welcome.

No. 1—Ferrous sulphate .....	250 gms
Sulphuric acid .....	3 cc
Warm water .....	1000 cc

Dissolve the salt in the water and add the acid *slowly*.

No. 2—Potassium oxalate (neutral—C.P.)	250 gms
Potassium bromide .....	1 gm
Warm water to make.....	1000 cc

Add 1 part of No. 1 to 4 parts of No. 2 *not* vice versa. After development and without washing rinse well in acetic acid; stop bath before placing in hypo. Should this give greenish tones decrease the amount of bromide. This has long been the great standby for bromide papers in England, next to amidol, and is a very good developer. Should there be a yellow stain the following will probably remove it.

Alum (saturated solution).....	1000 cc
Hydrochloric acid .....	40 cc

Wash well after this bath.

#### PUTTING SKY, OR FIGURES, IN LANDSCAPES.

Some new ideas in enlargements have been worked out in the last year, and it is possible that the readers of the *Annual*



may be interested in the reading of a simple direct method of putting in skies or figures in landscapes. The accepted method according to the "books" has been to make an exposure for the landscape and then an exposure for the sky and then develop them together. Most of us have tried that—we put a negative in the lantern and threw it up on a piece of bromide paper, and then drew a light pencil line where the sky line came, made our exposure, and then put our cloud negative in the lantern and tried to fit those clouds to the sky line. Then the exposure was made for the clouds and the print was slid into the developer. Then one of two things happened. Either the sky came sailing up as black as ink with an anæmic looking foreground or else the foreground came briskly into view leaving a sky which was a weak disappointment, or else white paper. Oh, yes, the exposure was tested but in these days of high prices it finally dawned upon me that to make a dozen enlargements and put a sky in each, from twelve different negatives each week, would require just thirteen weeks, to ensure my name appearing in the petitions in bankruptcy. Hence, the following method.

Make your enlargement of your landscape negative giving such exposure that it will develop to the point where it is as dark as desired. If your exposure is right it will go to that point and stop. If your exposure is in excess, the print when left in the developer until it stops will be too dark—if the exposure is insufficient the bromide will be too light no matter how long it is developed, and here let me say, that a bromide print, or a gaslight print will not develop more than the exposure has determined.

Don't be afraid to leave your prints in long enough. Insufficient development caused by the effort to save an over-timed print, never gives as good a print as one which has had the exposure so timed that when the print has developed as much as it will go, it is just dark enough. Herein lies the cause of poor sepias, in almost every case. When your prints are done developing they will stop—dead. If they're not dark enough, give more exposure. If they are too dark—less.

We make then, an exposure of our landscape negative so that it will develop until it is dark enough and then stop. Now place it for a minute or so in a weak acetic acid stop bath, and

then wash for three or four minutes in the dark. In the meantime, while it is washing, put your cloud negative in the lantern, put on an orange cap on the lense and after your enlargement has been wiped off with a clean piece of cheesecloth, pin it up on the easel. Now adjust your clouds in the sky and give fifty per cent more exposure than you would on dry bromide, as the washing and rinsing will slow your paper about that much. Take your paper from the easel, and place back in the developer, and develop your sky until it suits you—rinse in a stop bath and fix.

The explanation of all this is, usually the sky in a landscape negative is so black that it will print as white paper in an enlargement. If it does not, help it out a little with Bildup and graphite, or some opaque on the glass side of the negative, or with shading. The landscape is developed as far as it will go, and then the developer neutralized and washed out to a great extent. The sky being dense in the negative does not print and consequently does not develop with the foreground. The cloud negative can only print where there is unchanged emulsion i.e. the sky, and as a matter of course will print wherever the sky is blank, but will not print across treetops, houses, hills, etc. The depth of tone of the sky is under perfect control—in fact it is better to overexpose rather than under, as it is under control. If the print is to be sepia, the sky must be developed as far as it will go, but this is usually easy to do. Sounds complicated, but just try it.

Next placing figures in landscapes, or interiors. Suppose that we have a landscape, which could be considerably improved by the insertion of a figure. Determine the size of enlargement desired by making one of that size. Now with a pair of compasses, measure from objects in the enlargement, the height of figure necessary and photograph your desired figure in that size. Make contact print of this figure-negative preferably on glossy paper, so that it can be ferrotyped. Cut out the figure with a sharp pair of scissors, saving the part from which it was cut. Take your landscape or interior, place it in the lantern and (with orange cap on lense) tack your cut-out figure on the surface of the bromide paper with a dab of library paste. This will leave (when the exposure is made for the landscape) a masked spot undeveloped and after the



BOY AND PUPPY.

ALICE BOUGHTON.

first exposure has been made, and developed, we have the landscape, or what not, with the space occupied by the figure, unexposed and undeveloped. Now remove the little cut-out figure—it may remove itself in the developer, and sponge the face of the print to remove all traces of paste, rinse in acetic acid stop bath, and wash for two or three minutes. The piece of paper from which this figure was cut, which we saved, is pasted on the back of the negative of the figure to form a mask. After our enlargement has been well washed in the dark, we dab it off with cheese cloth and put it up on the easel. Our negative of the figure with its paper mask on the back goes in the lantern and we make an exposure, being careful to give about fifty per cent more than with dry paper. This is then developed and it will be found that it is very little trouble to fit the figure so closely this way that a very little spotting will take care of all edges. It is possible to put a figure from any size negative in any size enlargement, by similar means, which will be perfectly apparent after making one by this method.

#### PUTTING CLOUDS IN LANTERN SLIDES.

Again—clouds in lantern slides. I do not say that it is not possible to put clouds in lantern slides by double printing, any more than this is true of bromide paper. It has been done by patient men who are willing to spend hours of time, and dozens of sheets of paper or box after box of slides—I say it has been done. Personally I never knew anyone that could do it, had done it or had ever seen a slide made this way and my personal belief is that the only slide that was made this way was one of a white crow.

Cloud negatives can be had in many varieties, on film. The best ones I know of are sold by Butcher & Sons, of London. They may be had in all sizes, at a very small price, can be used either way around, and for the method I give here are the only ones that will do. Any dealer can get them. They are made on a very thin film stock, and are quite contrasty, and come in a large assortment.

Clouds are easiest to put in a lantern slide with a cloud negative of lantern slide size or quarter plate at most. After your lantern slide is made, fixed, washed and dried, adjust your



PORTRAIT.

Belle Johnson.



cloud negative on it so that the sky is to your taste, place a lantern slide plate on top of the cloud negative, and expose, being careful not to get the clouds too dark. The slide of the landscape acts as a mask, and when this slide we have just made is finished, it will be found that the clouds FIT the horizon no matter how the trees, buildings, etc., project into it, because the landscape slide was used as a mask and took care of all irregularities in the sky line. It works—I am using it daily—when I make lantern slides.

#### LANTERN SLIDES IN COLOR.

Lantern slides in color have been a favorite form of photography with me for years, and with the disappearance of supplies for the Paget plate, due to war conditions, the Autochrome has come into a little more prominence. There has been more twaddle written about these plates than any other one brand. Every user had a pet method of his own, and the majority of those who talked to conventions, and associations fell back on "the makers formula used as directions gives the best results, and you will find their little instruction sheet gives all that can be learned, except by experience." They used to say that, "He who is self taught has a fool for a teacher," and I often wonder whether this experience business is not the same. Practise—yes, but not experience. The autochrome has a plate speed—as do all plates. It also has a development speed in common with all other plates. Given these two factors it has been possible to work out a method for autochromes that will do more than the experience method in one way at least—it always works.

First, exposure—Watkins makes a special color plate meter, which takes into consideration the alteration in speed of the autochrome in different strengths of light. Any plate which is sensitive to the whole of the visible spectrum—or to the greater part of it, such as the color plates—the Wratten Panchromatic, and others, does not have the same speed in weak light that it does in strong. The stronger the light—other things being equal—the faster the plate. This is not a constant but varies on a law of its own which is embodied in the color plate meter. If we take the Autochrome as No. 2 on the Watkins Color Meter outdoors, on No. 1 indoors, it will be very close. This is for a slide intended for the lantern, and I

project my slides to a brilliant six or eight foot disc with a six ampere parallel arc lamp. If intended for hand viewing they may be a little denser. Dark objects, naturally take more exposure, but if you use the Watkins Meter you will find that the meter is built for objects of about the nature of an open landscape, and that there are factors given for 1—dark objects, old buildings, etc.; 2—sky and sea, distant view, etc., and if these are used with any judgment at all failure through exposure is impossible. I wish I could say as much for all the systems of estimating exposure. The unwary amateur can go into a supply-house and buy things which are enough to make a thoughtful man miserable for days when he thinks of what will happen when the amateur and the catchpenny trinket go out with a kodak.

Development of the autochrome is usually a matter of a table which you look at in the dark, and try to find where your graduate of developer is at the same time. Honourable men say that they have done this and gotten results by this method and I must believe them,—else where do we find ourselves with our confidence in the veracity of the human race undermined? There are two ways, by which we can develop with certainty. Using the Special Wratten Safe light for Panchromatic plates, and the Watkins Thermo Pyro Developer, with a dilution of 1 part A and 1 part B with 6 parts of water, we have a factor of 5. Now, it is possible to see the image, leaving out the sky lines, as soon as it appears if one will only wait a little after entering the dark room. Owing to what is known as the Purkinje phenomenon, the green light of the safe light while not strong enough to fog the panchromatic emulsion is more easily perceived by the eye than a red one of equal strength—i.e. the green light is safe because it is so weak—but the eye can see with it. A red one which was weak enough to be safe could only be seen by the eye with some difficulty.

Taking then, some prominent part of the image as a guide we develop factorially, giving five times the appearance time. The plate is then reversed in the bichromate reverser, exposed to strong light, washed about thirty seconds, and dried. After drying, it is re-developed in the same developer that was used





AT ROTHENBURG.

T. F. BROGDEN.

for first development, as far as it will go, washed for about sixty seconds in running water and dried.

The bichromate reverser tends to toughen the film and is much more convenient to use than permanganate as it has always been a pet theory of the writer's that 1 gram of potassium permanganate, properly used, would dye the universe a rich pink, from his experiences in getting it out of sinks, etc. The object of allowing the plates to dry after reversal is to toughen them so that there will be no danger of frilling. Should there be any trouble from this source, rinse the plates after reversal in the bichromate solution, and then place for two minutes in a solution of chrome-alum (which should be in dark purple crystals, without any grey powder on the surface,—and will be if it is good) of a strength of 1%—10 grams to the litre. Rinse, allow to dry, and re-develop, and frilling will vanish.

Now after your plate is done. If it is over-exposed it will be thin and weak. If it is under-exposed, it will be dense and have no detail. If you have plenty of detail and yet the slide is too dense, use a larger factor next time. If you have plenty of detail and the slide is all right but is too thin, use a smaller factor next time. Density of slides is like the length of a piece of string—two men look at the same slide and one says, "Thin," and the other says, "Dense." Put it in the lantern or in the diascope—and you will soon know. Autochromes can be made as thin as a Paget if desired,—full exposure and a factor a point or so larger.

The advantage of using the factor is that after your first slide it is easy to determine just how long to develop. With the other methods there is enough variation in the speed of the plates in development to throw one clear off the track.

The other variation that is possible in development, is to use a five per cent solution of potassium metabisulphite for about four minutes in complete darkness before first development. The plate is immersed in this solution for about four minutes in the dark, and then washed for a couple of minutes—also in the dark—and may then be developed by the ordinary ruby light. This method works excellently, although it is apt to vary the factor considerably, and not always to the same extent, as a varying amount of the acid salt is always

carried over into the developer. Altogether, I would advise the use of the special Wratten Safelight for Panchromatic plates, and straight factorial development. If a little care is used in varying the development factor, or if necessary the plate speed of the autochrome, it will be found easy to make these plates as transparent as may be desired. Give exposure enough so that there is plenty of detail, and develop with the factor given until you see what the first plate comes to and then change your development speed by making the factor larger if your finished plate is too dense, or smaller if it is too thin. But after you have determined the kind of autochrome you want, you will find that using a plate speed of Watkins 2 and the factor (normal or otherwise) given will give you as good autochromes as can be made.

One more point about autochromes and I must close. If for any reason you find blue Fog all over your slide—your camera or slide is leaking somewhere. Hunt up the leak and fix it but to save the slide try this. Fix out a lantern slide plate, and wash it and dry it and then with Japanese water colours, or Velox water colour stamps colour it a light yellow all over. Place this over your autochrome and you will find that a very small amount of yellow in this cover glass will counteract the blue and your slide will be useable at least. I have a birds-eye view of one of the eastern cities, which was a lovely blue cast when completed owing to a leak in my dark slide, at one end. A light yellow cover glass corrected this and it is almost as good as if it had been free from light fog in the beginning.

I find that I have neglected to give the formula for the Watkins Thermo Pyro so will append it here.

No. 1—Pyro .....	74 grams
Potassium Metabisulphite.....	37 grams
Sodium Sulphite, dry .....	400 grams
Water to .....	2000 cc
No. 2—Sodium Carbonate, dry .....	400 grams
Potassium bromide .....	18 grams
Water to .....	2000 cc

Use one part of each with six parts of water for autochromes. The factor is 5. This is the standard thermo developer and can be used with the dilutions given in "Science and Practise of Photography"—by Alfred Watkins.

## WATER PANORAMS

By C. H. CLAUDY



FROM his photographic infancy the amateur is taught that different cameras are suitable for different kinds of work. He is told that a view camera is good for views, a speed camera good for speed pictures, and that a speed camera is not good for views, nor a view camera good for speed work. He learns that a kodak is better suited to snapshots than it is for the making of copies, and that a telephoto instrument is not the most convenient for the making of portraits.

He also is told that while he can make panorama pictures with most any kind of a camera by making successive negatives and joining the prints, the easiest way to make a panoramic picture is by the use of a panoramic camera.

He learns that there are two different kinds of panorama cameras. In the one—which is expensive, heavy, elaborate and extremely efficient—the whole camera revolves, while a roll of film unrolls over a slit in the inside of the instrument. These Cirkut instruments, as they are called, will make pictures of impossibly large and expensive lengths. They are a delight to play with—if someone else buys the films and paper.

The amateur's very own panoramic instrument, however, he is taught to be that variety of kodak called panoram. In these the lens, not the instrument itself, makes a partial revolution, thus "wiping" the image on the film, in the way familiar to most beginners.

But so far as I am aware, no one has yet issued a set of instructions that no instrument is better for the making of water scenes than these same panorams. Not view instrument, not speed camera, not stand instrument nor pocket kodak, can really compete with the panoram as a maker of water-views.

There are half a dozen ways of proving it, but perhaps a glance at the accompanying little pictures—collected from



CHILD PORTRAIT.

SIDNEY V. WEBB.

everywhere and submitted entirely as attractive water pictures with no thought whatever that they are masterpieces, is the easiest.

However, there is more than visual proof. There is a reason why a panoramic picture of a water scene is the most attractive presentation it can have.

That reason is so simple it hardly needs telling. It is an ancient art principle that the shape of the view—the picture seen through its margins or its frame—must bear a definite relation to the view itself. For instance, no picture which demands any consideration as artistic can have an equal expanse above and below the horizon line. It can have two thirds or three fourths sky—if the sky is beautiful enough to need so much, as one third or fourth foreground. Or it can have the majority of its interest below the horizon line. But it cannot have an equal division. Take any of the several little pictures shown in connection with this story and add—in imagination—enough sky to make them square. Would the result have any interest? Of course not.

*But sea and water pictures seldom have much of interest for any distance below the horizon line.*

Their main interest is in their extent to east and west. On the seashore as we stand close to the waves we must look to right and left to gain an idea of the majesty of the sea, the beauty of its wide expanse, the wonder of its area.

Now if we have but little of interest *below* the horizon line and not much *above* it, there isn't any picture left—except we extend it to east and west—right and left.

And that is exactly why the panoramic picture lends itself so readily to the delineation of water scenes of all kinds.

Take any of the panorams published here and trim out any part of any one, to the familiar 4 x 5 proportions. The result—I care not which one you select for the experiment—will be but a commonplace picture, the kind of picture that is a drug on the market, the kind so often made by turning the lens on a water scene and trying to get a wide expanse to either side to look interesting in a contracted space.

Agreed, that out of several of these panorams one could chop several compositions, thus proving what the artist usually



WOODLAND STUDY.

P. J. SCHWEICKART.

contends against the panorama, that it is not really one picture but several, placed end to end.

But we are not bothering about the artist. He is all right, is the artist, and he knows his job and his book and his pictures beat anything we poor hit-or-miss snapshotters can do. But just the same when he tells us that a panoram isn't pretty because it isn't shaped according to the canons by which worked Mike of sainted memory, we put up a hand to warn him from our presences!

We find the panoram a mighty attractive shape, and when we come to look over the work we do with it, we find that it is the water scenes, with their wide expanse so satisfyingly portrayed in the long and narrow shape which please us most.

There is another reason, too. I wasn't going to speak of it, for it seems a shame to find any flaws in a thing you have just



Figure 1.

praised for full a thousand words! Nevertheless, it must be admitted that any sort of a panoram made with a revolving camera or lens, does distort the facts of nature. You can't get away from it—a panoram distorts straight lines and makes them into curves. If you want to see how much, make a vertical panoram picture of a tall building from a close viewpoint and you'll find that Pisa and her leaning tower are all out of class!

But—what you don't see cannot scare you and what you don't feel doesn't hurt you, as the Irishman said to the visitor who exclaimed in wonder at his allowing his wife to beat him with the feather duster. And so the straight lines made into curves in the panoram of a water scene don't bother our eyes—first because there are so few straight lines in the average





A. MC FARLIN.

water scene, and second, because they are just as pretty and attractive and natural when turned into a curve.

Proof? Look at the exhibits! I dare say the left hand edge of the path which is the edge of the lake in which the swans and ducks are about to disport themselves (Figure 1) is as straight in nature as the right hand edge of the path which is the edge of the hill. But does it appear any less attractive or natural that it is curved in the picture? It does not.

But a picture of a street, which we know is straight, is awkward when it comes out a curve, or a building which we know is square, if it comes out shaped like a plum! So the other reason water scenes are particularly good subjects for the panoram is that distortion—a necessary evil in the instrument which wipes the image on a curved film—fails to show.

So to my list—and your list too—let us add this. We will use Kodaks for snapshots, and portrait cameras for portraits. We will use speed cameras for speed work and telephoto cameras to make distant views. We will use Cirkuts, or panorams, to make panoramic pictures and we will also, from now on, use them for water scenes, as the instrument par excellence, best fitted to show a view which is beautiful only and principally because of its wide expanse and its feeling of uncramped distance and breadth of vision—a width and breadth, a distance and a spread which cannot be confined successfully within the limits of the angle of view of the average instrument we amateurs possess.



*Illustrating article "Water Pancrams," by C. H. Claudy.*

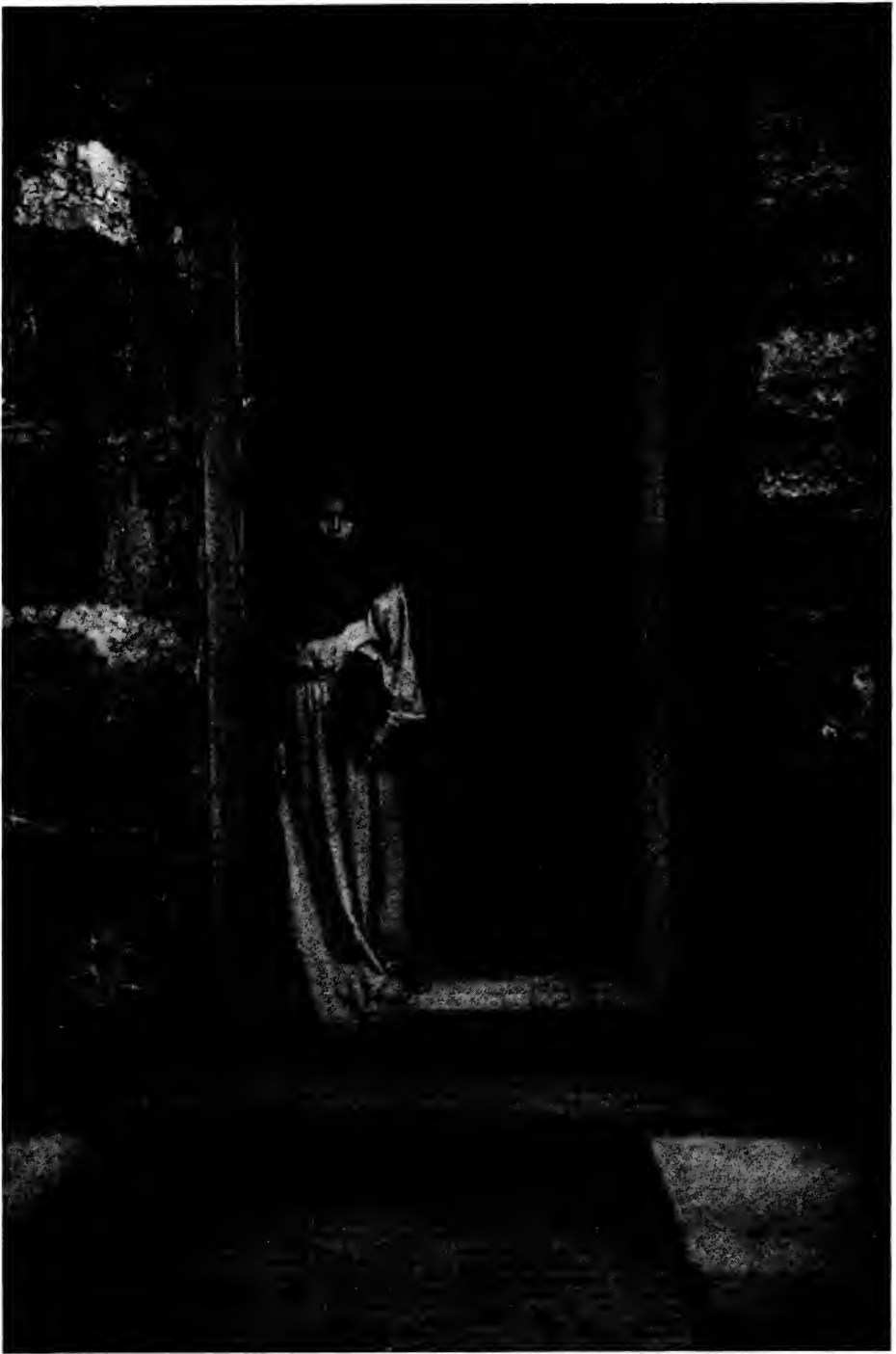

A THIRTEENTH CENTURY MISS.

WARREN R. LAITY.

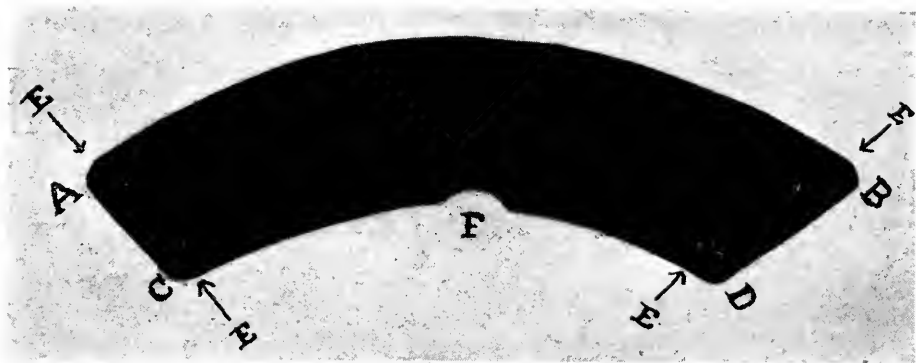

Figure 1.

Illustrating article "A Portable and Practical Lens Shade," by John Boyd.

## A PORTABLE AND PRACTICAL LENS SHADE

By JOHN BOYD



LENS shade is a necessity in every branch of photography. Its use adds brilliancy to every negative, and makes easy work of some of the difficult phases of the art. You can work directly against the sun at midday without getting haze or fog. Flashlights giving unusual effects are easy by its use. It is a wonder that its beneficial features are not more appreciated. I suppose it is because those devised to date are so bulky and unportable.

A few years ago I described in this *Annual* a shade made out of a pocket drinking cup. I have heard of its adoption from all parts of the country, and praised enough to warrant me publishing my latest wrinkle along the same lines.

The one I have now perfected is simpler than the former; more easily made; handier to carry, and costs—well—it shouldn't cost anything.

It is made of a piece of fairly stiff black leather, preferably sole leather and about 1/16 of an inch thick.

Its shape as finished and ready for the pocket is as per Figure I, while in Figure II the shade is seen in actual position on the camera.

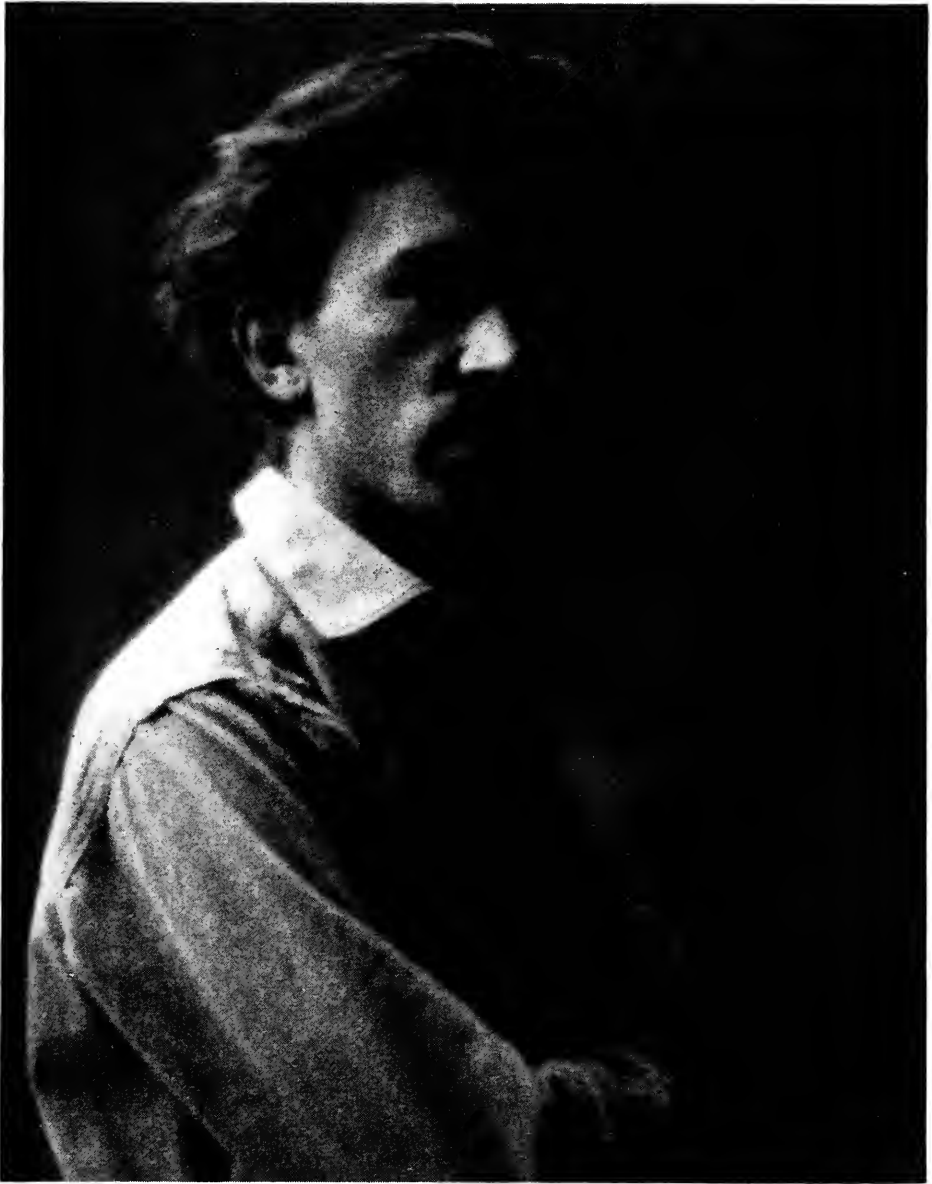

PORTRAIT OF AN ARTIST.

LOUIS FLECKENSTEIN.

A. B. C. D. is the shape of the piece; E. E. E. E. are two pairs of complete glove fasteners, while F. is a small section cut out to enable one to read the stop numbers on the lens when the shade is on.

The size of the piece will have to be determined by the diameter and angle of your lens. A good way to ascertain



Figure 2.

this, is to take a piece of paper and pass it around the barrel of your lens—this will give you the length from C. to D.

The flare of the shade, i.e. from A. to B. must be sufficient to clear the angle of view included by your lens, which on an ordinary rectilinear or anastigmat will make the length about



John M. Whitehead.

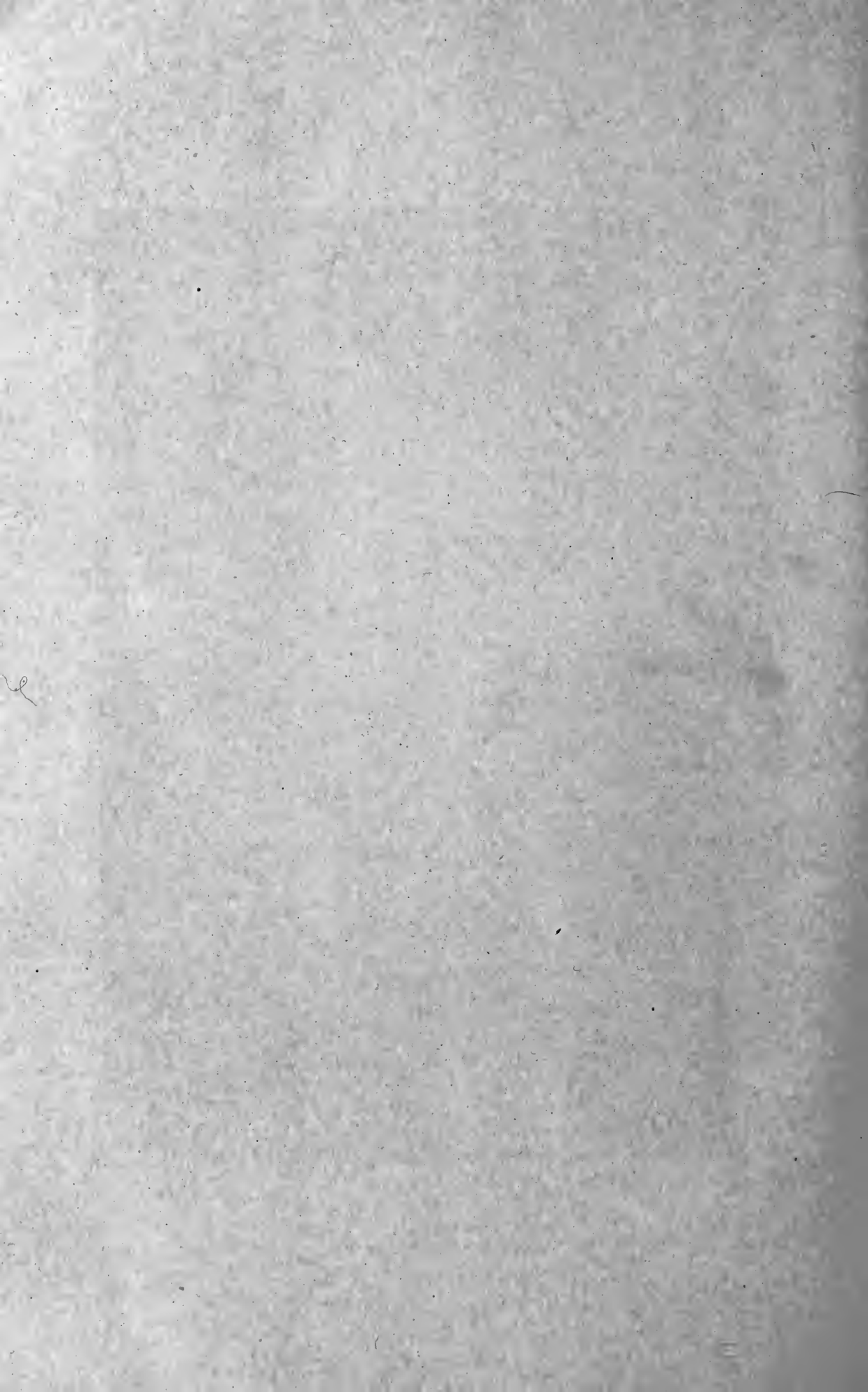



3 inches longer than that from C. to D. This however had better be determined by experiment.

The glove fasteners can be sewed on by hand, but your shoemaker or glove store will put them on by machine in a couple of seconds, and do it much neater.

The "cut out" at F. is only necessary when the diaphragm markings are engraved on the barrel of the lens, and this can be scooped out after the shade is finished.

The inside must be well blackened, so that no reflections can reach the lens—this is important.

You now have a shade that will go into your pocketbook, or coat pocket; lie flat; take up practically no space; and will last you your photographic lifetime.

It takes less time to make it than what I have consumed in describing it, and I stand ready to guarantee that your work will be improved many hundred per cent by its use, even when the sun is at your back.

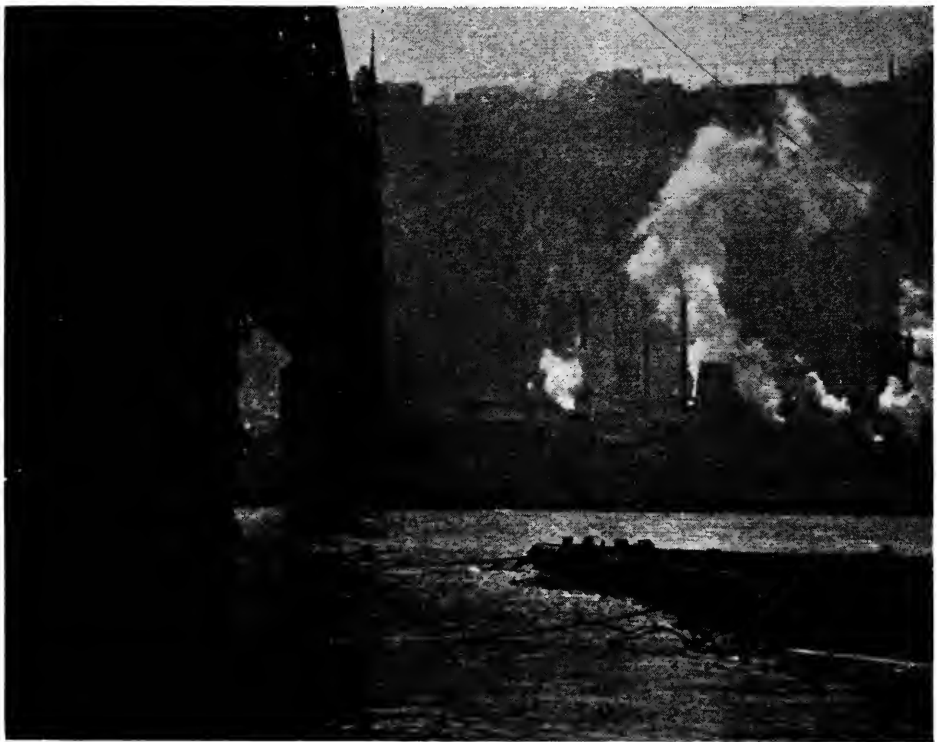

THE MILL ACROSS THE RIVER.

CHAS. W. DOUTT.

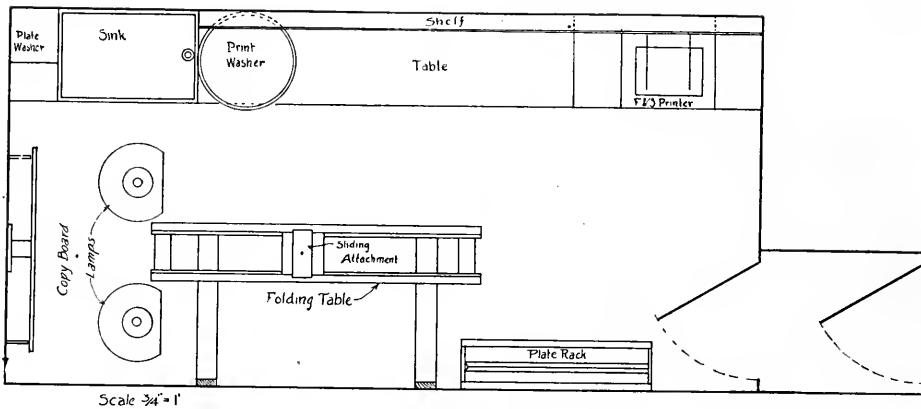

Figure 3.

Illustrating article "A Convenient Dark-Room," by C. E. Owen.

## A CONVENIENT DARK-ROOM

By C. E. OWEN



BELIEVING that a first class dark-room is one of the essentials of a successful photographic business, I have been tempted to write on this subject, and to describe one which, I think, has many good features I often find lacking in photographic establishments. The room which I am about to describe was intended for commercial work only, but I find that there is, after all, very little difference in the requirements. To be as brief as possible and to bridge over gaps in the description, I have supplied two pictures (Figures 1 and 2) and a diagram (Figure 3).

The room is about eight by sixteen feet as shown on the diagram, and is intended to be used for all photographic operations except possibly drying and mounting.

The equipment consists of the following, which you will note on the pictures and diagram. (Figure 1.) Beginning on the left you will note first the plate rack which is attached to the wall and has a draining trough under it, and is made to hold about four dozen plates at one time.

Next, you will note the folding table for copying and enlarging, with a camera in position on it and also one of the lamps in position. Two one thousand watt mazda nitrogen lamps are used for copying, and when not in use are hung on



Figure 1.  
*Illustrating article "A Convenient Dark-Room," by C. E. Owen.*

the wall while the table folds up against the wall also, as shown in Figure 2.

In front of the camera at the end of the room is the copy board 32 x 48 inches. It is hung on the wall by means of an axis at the center on which it may be revolved. It can also be raised or lowered so as to bring the center on a level with the lens which is being used. It is not necessary to shift it side-wise as that is taken care of by the fixed position of the table which is hinged to the wall. There is a folding shelf below the copy board, and in the corner at the left is a stand on which is kept two large blotter books for drying prints. In the right hand corner is the plate washer of the regular type, next is the large sink, and above this on the wall is a small cupboard or cabinet.

On the end of the large table is a print washer, which is constructed from a large galvanized tub with a hose and spray nozzle emptying completely and periodically by means of a siphon attachment.

On a swing bracket above the end of the table is the ruby lamp, which can be turned in any direction and is always out of the way. Note that the table is double, giving a handy place to store trays, tanks and other things when not in use.

Figure 2 shows the opposite end of the room and in the corner at the end of the table is the 11 x 14 Eastman printer with the timer above and a small shelf for negatives which are in use. Then comes the double doors and the plate rack in this view. The enlarging table is folded up out of the way. Under it is a small copy board which attaches to it and is used for close work with short focus lenses. There are two ventilators which are not very evident in the pictures as one is under the table, and the other is behind the large copy board which is about 7 inches from the wall. A large quantity and a great variety of work can be handled in this room, and if it were necessary all the work of an ordinary photo business could be done in a room not much larger than this, except that materials and apparatus would have to be stored outside of this space.

As the ideas embodied in this description have been of great benefit to the writer, he believes that they will justify a careful study by all those to whom economy of space and efficiency are essentials.

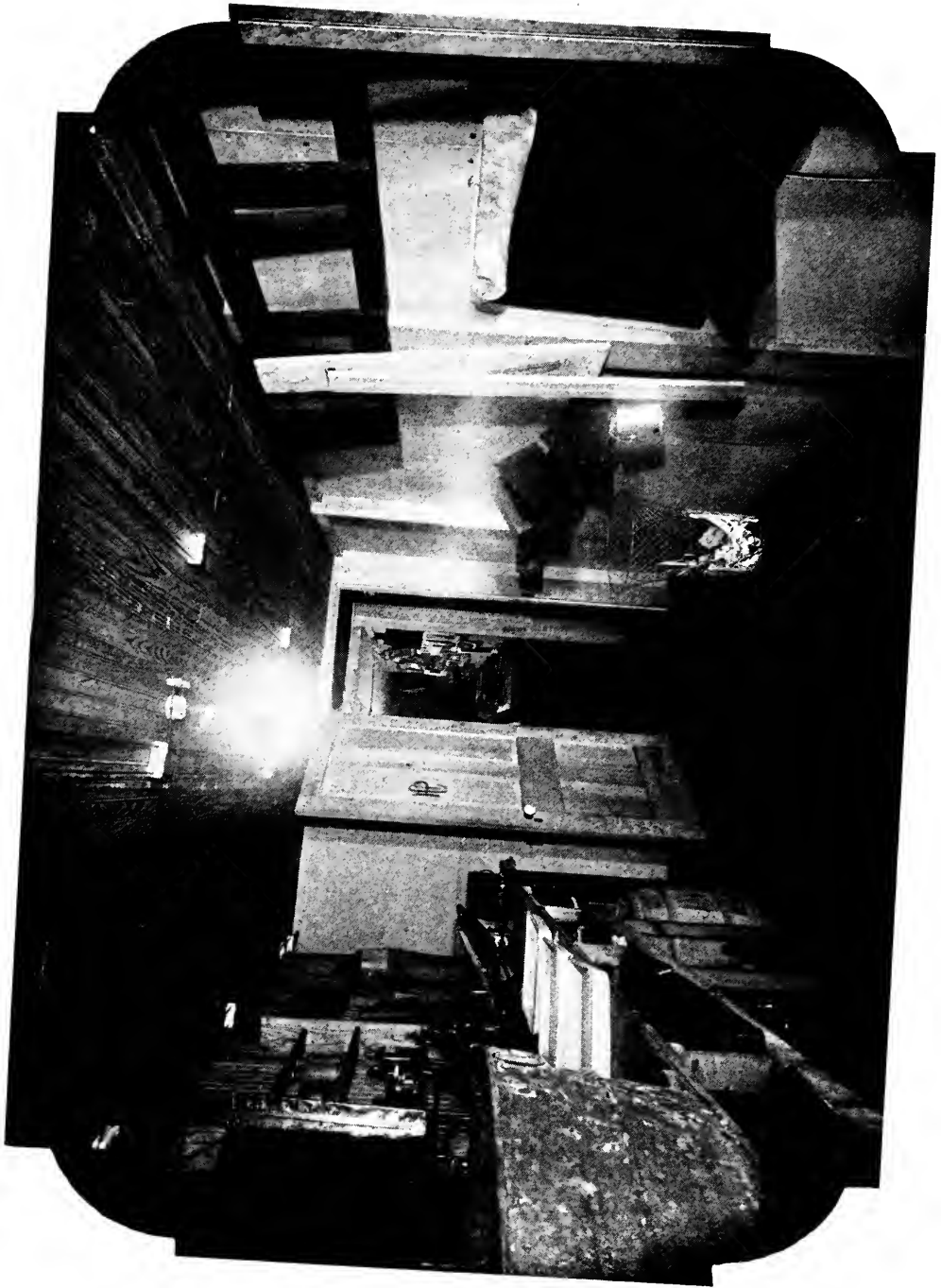

Figure 2.  
*Illustrating article "A Convenient Dark-Room," by C. E. Owen.*

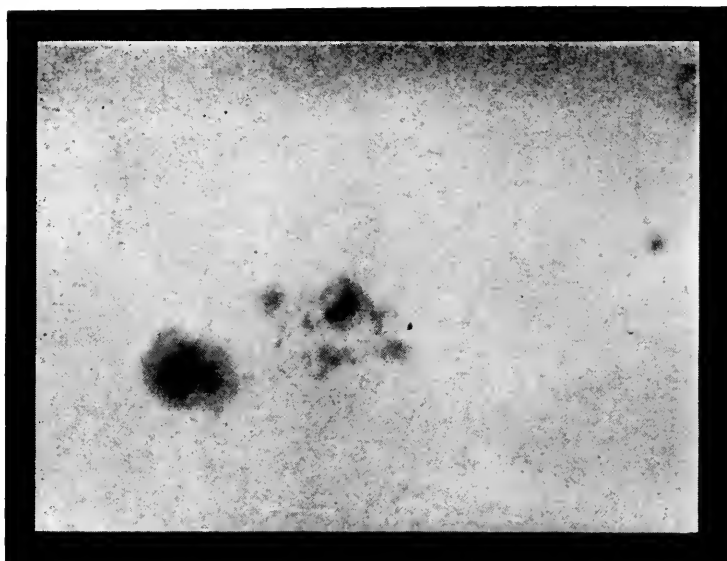

Figure 1.

A GROUP OF SUNSPOTS.

*Illustrating article "Photographing the Sun," by William Henry.*

## PHOTOGRAPHING THE SUN

By WILLIAM HENRY



HERE are several branches of photography which are seldom attempted by amateurs, either because they think them too difficult, or possibly because they never thought about them. Amongst these we may mention astronomical photography which very few—either amateurs or professionals—ever attempt.

No doubt astronomical photography is difficult as, especially in stellar work or photographing comets, it is absolutely essential that the cameras move by clockwork to counteract the motion of the earth, owing to the prolonged exposures necessary.

In solar photography, however, we meet conditions which are favorable to successful work by the amateur who possesses even a small telescope. This is due to the fact that in photographing the sun it is necessary to use very fast exposures, as the image is so excessively brilliant.

In photographing the sun I leave the eyepiece in the telescope, and in that way get an image of the sun about four



KINGS RIVER CANYON, CALIFORNIA.

S. H. WILLARD.



Figure 2.  
*Photograph of the Sun Showing Sunspots.*

inches in diameter, while using a telescope which has an object glass of three inches in diameter. This size of image enables us to photograph a great many details on the sun's surface—even if it is 93,000,000 miles away. Amongst the details we see on these photographs, the most prominent are the sunspots. (Figures 1 and 2.), then the faculæ or white clouds of metallic vapors floating above the surface of the photosphere, and also details of the photosphere itself. The faculæ are best shown when near the sun's limb; but the spots show at any stage of their journey around the sun when on the side turned towards us.

In solar photography I find it convenient to use a right-angle prism between the object-glass and the eyepiece, as in





IN THE BLUE MOUNTAINS, N. S. W.

Harold Cazneaux.



this way we can point the camera away from the direct rays of the sun. (Figure 3.) Anyone with a reflecting camera, by removing the lens and focusing the projected image from a telescope on to the ground glass, should be able to get good solar photos. It is necessary to use slow or process plates to secure the best results, and at the same time stop down the lens while using very quick exposures.

In developing these negatives, care should be taken not to over-develop, as it is very easy to get them too dense. In printing also great care is necessary to use a paper which is suitable to the negative, giving brilliancy and at the same time good detail.



Figure 3.

*Illustrating article "Photographing the Sun," by William Henry.*



Showing the worst distortions (wheels) that will happen with a good shutter. Nettel camera. 7" F. 4.5 Tessar. 1/560 second exposure. Trotter going full speed, distance about 6 yards.

*Illustrating article "The Focalplane Shutter and Its Aggressors," by A. L. Gareis.*

## THE FOCALPLANE SHUTTER AND ITS AGGRESSORS

By A. L. GAREIS

**I**N past issues of several of our periodicals and photographic textbooks the results obtained with the focalplane shutter have been attacked, the shutter itself condemned and the diaphragm shutter mounted upon vest pocket cameras declared to be "the" instrument for the modern amateur. After having read so much aggressive literature I could not refrain from writing a few words in defense of my old friend, the focalplane shutter, mounted upon cameras of medium size, viz.:  $\frac{1}{4}$  plate, 9x12 cm, 4x5", etc.

It is quite evident that most of the articles containing nothing but contempt for the focalplane shutter emanated from the pen of two classes of photographers: First, amateurs who used a cheap, unreliable instrument; second, those not knowing how to use a good instrument.

For fear to be misunderstood I want to state that I do not condemn the vest pocket camera which is just as valuable in some respects as its larger brothers, neither do I deny that an



Inside Snapshot, 1/10 second. Suter Aplanat—10" F. 6 Lechner Werner camera. Lumiere Violet Label Plate. Lechner 13:18 Focalplane shutter. (Room with one window.)

*Illustrating article "The Focalplane Shutter and Its Aggressors," by A. L. Gareis.*

accurate shutter working between the lens combinations is superior to the focalplane in some instances, especially when fitted to a high grade reflecting instrument (Newman Sinclair front shutter reflex camera, Newman & Guardia Front shutter reflex camera, Voigtlaender Stereoflectoscope, etc.), but I do emphatically contend that for super-speed photography under unfavorable light conditions the focalplane shutter is a necessity.

To prove my contention I will have to elucidate the effect produced by a photographic shutter. (To facilitate understanding metric measure is used in the following explanation.)

Supposing a subject moving at the speed of 1 meter per second is to be photographed with a quarter plate camera fitted with a lens of 15 centimeter focus, from a distance of 15 meters. The subject be a running child, height 1 meter. The child's legs will move at a speed of 2 meters per second if the 1m distance is covered with two steps. The image cast upon the ground glass will be 1/100 of the actual height of the child, viz 1 cm obtained as follows:

$$\frac{\text{focal length of lens} = 15 \text{ cm}}{\text{actual distance} = 1500 \text{ cm}}$$

and said image will move 1/100 the distance of original in a given time, for the same reason. Here it will be well to remember that in theory we cannot speak of a "stopped" motion, for no matter how slow the subject moves and how fast the shutter works, the relation can never become zero =  $\frac{m}{\infty}$  or  $\frac{0}{m}$

for the simple reason that the speed of the shutter cannot be infinitely fast, neither can the object move at a zero speed, because we cannot speak of movement in the latter case. If the subject moves, there will be some movement of the image equal to

$$\left( \frac{\text{focal length}}{\text{object distance}} \times \text{speed of object} \right)$$

This fraction cannot become naught unless the subject is at rest or infinitely far away. In practice, however, we consider the motion "stopped" if the movement upon the sensitive surface does not exceed 0.1mm, for the simple reason that the human eye cannot distinguish any blur beyond a higher limit than the above.



T. JACKSON.

THE STACKYARD.

Going back to the example: The distance covered in one second would be equal to 200 cm (legs), the movement upon the ground glass, or sensitive surface, will be 2 cm in one second and we need a shutter working at one two hundredth of a second to obtain a sharp image of the running child's legs ( $1/100$  of a second might suffice if no enlargement is required). These figures show that the best diaphragmatic shutters will be just about sufficient to "stop" a running child. (It is possible to obtain a clear picture of the legs even at a lower speed, if the moment is caught when one leg just reaches the ground whilst the other leg reaches the limit of its forward motion, ready to be lifted. Such "right moments" are often the reason why jumping animals are obtained sharp with a low speed and poor light.)

The above are certainly not very encouraging facts if one considers that only three shutters are made with a reliable speed marking, tested and certified upon by a scientific institution of Great Britain. (Adams Exacto shutter, Compound shutter, Newman & Guardia shutters of their boxform "Universal" cameras.) It is, of course, possible to construct shutters working between the lens-cells and giving speeds up to  $1/4000$  of a second and more (Multispeed shutter), but unfortunately our sensitive material is not adapted to such tremendous speeds. The fastest plates on the American market are the Marion Record plates with the Speed number F 128 on the Wynne meter.

A Wynne meter will show about  $1\frac{1}{2}$  to 2 seconds actinometer time in strong sunlight, midsummer, 11 a.m. to 1 p.m. so that with the fastest lenses made for ordinary cameras, the meter calls for an exposure of  $1/1000$  of a second, *if* the lens works at its full aperture *all* the time during exposure. In consequence, nothing but a focalplane shutter will yield a fully exposed image, as it is a mechanical impossibility to construct a diaphragm shutter which requires  $1/100$  of a second to open and  $1/100$  to close. No matter how the shutter is constructed, the blades will take some time to "get out of the way," and about the same time to completely close, whilst the "exposure" time must be calculated from the moment the blades begin to open to the moment when shutter



is completely closed; otherwise a blurred image would result, if fast-moving subjects are photographed.

In my own twenty years' experience I found it quite a difficult matter to obtain fully exposed negatives at  $1/1000$  part of a second, and I only used the very best, the "cream" of instruments. This is due to the above facts, and in addition to the proximity of subjects, to their dark color, etc. It would be easy, of course, to obtain a fully timed negative of distant land—or seascapes, but there is no need to give an exposure of  $1/1000$  part of a second if one takes such pictures. For horse races, auto races, flying birds, moving insects at very close range, etc., a good focalplane camera of the Goerz Anschuetz and reflecting type are the best and only really reliable instruments. I used every first-class camera on the market, but the best results I obtained were invariably those taken with a focalplane instrument, on medium-size cameras, fitted with long focus lenses.

The lack of depth never spoils such photos, in fact it often tends to make a real picture out of them, inasmuch as the secret of a good "picture" is founded upon the subduing of all unnecessary detail, thus making the principal subject "stand out" prominently from a diffused background. Although I am an enemy of the modern diffused portraits and landscapes, etc., for the same reason as I do not fancy a foggy day or smoky atmosphere, I do believe in subdued detail under certain circumstances.

The most striking injustice to the focalplane shutter was done in an issue of a photographic periodical some time ago. A boy was shown riding a bicycle; the wheels of the machine showed an ugly oblong shape due to the action of the focalplane shutter. For twenty years have I used focalplane shutters, but I never obtained anything like the pictures shown in said magazine. In fact there was never any perceptible distortion unless I wanted such a result: Let the shutter slit be  $1/32$  of an inch, let the curtain travel at slow speed, let the subject move at right angles to optical axis at a high speed and, provided the blind works vertically downward, the result will be a badly distorted picture. It is quite evident that the writer of the article referred to either used

a poorly made instrument, or else he just "fixed" matters up to suit his purpose.

A really first class focalplane "hand" camera cannot be had for less than about \$100—for the outfit, or, if a reflecting instrument is desired the amount must be doubled. (Quarter-plate size.) But such an instrument will be a constant source of enjoyment for its user and repay the original outlay by the



Enlargement of  $1\frac{3}{4} \times 1\frac{3}{4}$  negative taken in bright sunlight. Stere-flectoscope, W. 2 Heliars. 62 mm. focus. Compound shutter.  $1/250$  sec. Distance, 15 yards. Lumiere Violet Label Plate. Despite the favorable conditions negative is underexposed. (Note difference in this and the picture taken with Focalplane Shutter at four times the actual speed.)

pleasure experienced in handling and, of course, by the unapproachable results.

Like any scientific instrument, the photographic precision camera requires interested study before the best results can be obtained. How true this is only those photographers and artists (amateurs, who do the work for its own sake) can realize, who know how wonderfully complex and far reaching the modern science of the photographic art actually is. Artistic inclination, knowledge in chemistry, physics and phys. optics, etc., are qualities a successful amateur should possess if he wants to criticize an instrument, but first of all he must have used the *best* instruments of the various makers, otherwise he has no right to defame a reliable instru-



A COUNTRY ROAD.

James N. Doolittle.

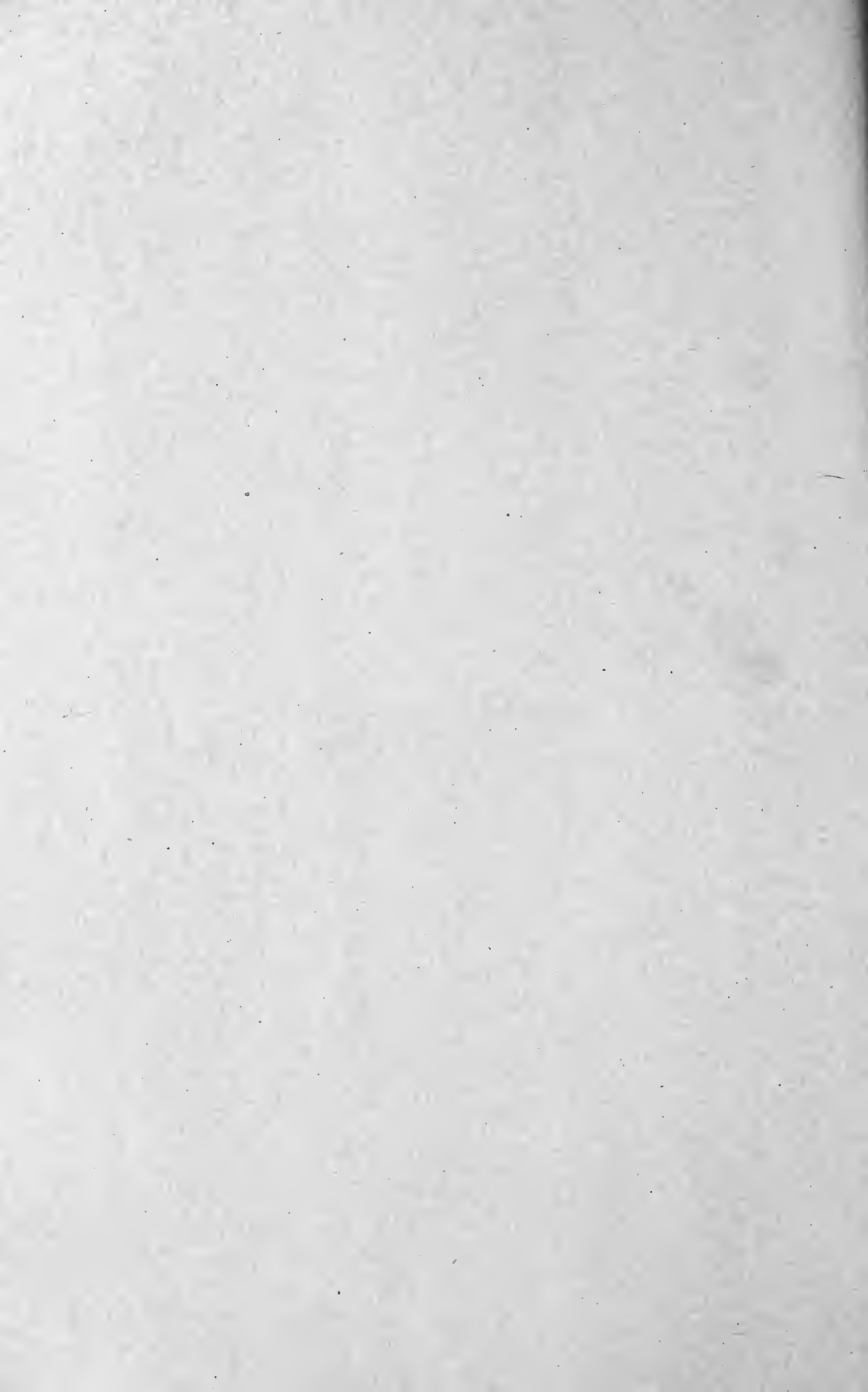

ment. What would a civil engineer say if a layman wrote an article condemning the theodolite, the plane table and the transit, boldly contending that a pocket transit or a pocket sextant in connection with a sketching board was all there is required for triangulation?

I personally value my small pocket instruments highly, especially the smallest stereo cameras, still I would much rather part with the Baby Sibyl, the Vest Pocket Vesta, the Zeiss Bébé, the Stereoflectoscope, etc., than to do without my Werner View Camera, my Minex, my Goerz Anschuetz, or Lechner 9:18 Stereo Reflex. I mention the above instruments just to show that I know what I am talking about. I could fill a volume just listing "cameras I have used," and I would not dare to condemn one class of instruments (except the soft focus lens, which is a perversity, as it shows "nature" as it appears "the day after"). They all have their individual right and if the amateur will only either go to a reliable dealer or ask an experienced photographer to advise him as to the instrument best suited for his purpose, results like the one reproduced in the said magazine would not appear.

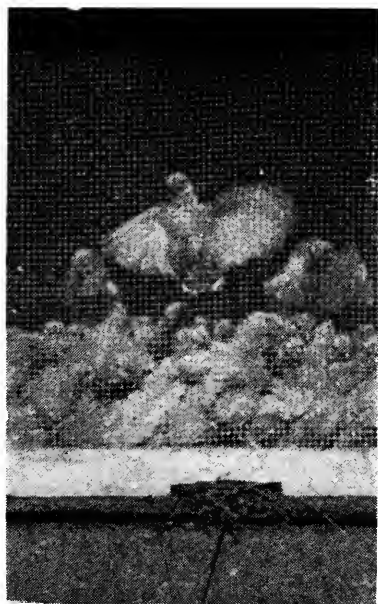

Distance of subject 2 yards. Heliar-Bijou-Reflex. 1/1000 second. Chickens In Flight. (4" Heliar.) This picture cannot be duplicated with a diaphragm shutter at 2 yards distance.  
*Illustrating article "The Focalplane Shutter and Its Aggressors," by A. L. Gareis.*

# TECHNICAL AND ARTISTIC BUTTERFLY PHOTOGRAPHY

By DR. R. W. SHUFELDT, C. M. Z. S.



SOMETIMES it is an extremely easy matter to make a good photograph of a living specimen of a butterfly, while again, upon the other hand, it may turn out to be one of the most difficult little tricks in the entire range of zoöphotography. As a rule, it is the rarest exception to secure useful and pleasing pictures of this kind when dead butterflies are selected as subjects; indeed, in many cases it proves to be more trying to pose a dead and limp specimen than it is to go properly to work and make an exposure upon a living one in one of its natural attitudes. Personally, except in very few instances, I shun such material for my purpose and use only good, vigorous, and absolutely perfect butterflies. As I say, there are exceptions to this, as when one receives a dead specimen of great rarity, and it is essential to preserve a photograph of it for scientific purposes or for preservation. Then I make the best possible negative of it, and this often requires all the skill the trained naturalist possesses, added to his knowledge of technical photography.

For museum and other collection purposes the preservation of butterflies is carried out along lines which have long been followed by the professional lepidopterist, the specimens being painlessly killed, prepared according to certain rules, and spread out to dry on drying-boards, made especially for such uses, being finally consigned in a classificatory way in trays or cases for reference. This, in brief, is the method of the butterfly collector, and one of his prepared specimens has much the appearance of the insect here shown in Figure 1. For illustrative purposes, either plain or in colors, the correct photography of such specimens is quite an art in itself. Sometimes they are classified and beautifully grouped, as many of them appearing upon a single plate as their size will admit.



Figure 1.

A CORRECT WAY TO POSE A BUTTERFLY.

These plates are generally very attractive, and extremely useful to the student of the subject as well as to the amateur collector. Admirable examples of these may be seen in the plates illustrating the famous work of Dr. W. J. Holland, "The Butterfly Book," now employed far and wide by butterfly collectors and experts. Here the aim has been not only to give accurate, colored reproductions of each species, natural size, but to arrange them on each plate, in a taxonomical way, so

as to have the whole attractive and at the same time present an absence of all crowding, thus saving as much as possible the expense of reproduction. Whether made plain or in color, there are certain procedures to be carefully followed here in order to obtain the best results.

In the first place, the condition of lighting must be absolutely perfect, or immaculate backgrounds cannot be secured. The specimens should be accurately placed in the horizontal plane, with the visual line of the lens perpendicular to it. Practically, the spread wings of all the specimens to be taken on the same plate should be in the same horizontal plane, and this plane parallel to the one to which they are fastened. Other parts, as the bodies and so on, should be as nearly in the plane with the wings as the mounting will allow. This is generally the case, and the stop used will bring all into due focus. Antennæ and other structures should be *perfect on every specimen* and properly arranged.

In such plates it is sometimes necessary to exhibit both lateral and inferior views of certain specimens, and this can be accomplished without much additional difficulty. Whatever the adopted arrangement may be, the spread of the wings should be uniform; the bodies in the same straight line; the angles of separation of the antennæ the same, and the whole made attractive to the eye. There are many examples exhibiting complete success in all this in Doctor Holland's work mentioned above, and Plate XX. in it will exemplify my description as well as any of them. In some of the forty-eight plates, all in color, there are occasional slips; but these may be expected where the illustrations are so numerous, and the technique of such a difficult character. In some of the plates it has been aimed to incorporate flowers and parts of plants as accessory features, and in most instances unusual success has been attained in such attempts.

Now, in the photography of living specimens of butterflies, we may be influenced by quite a number of factors that are sure to be met with in every operation. These may be more or fewer, owing to the nature of each individual case, and the character of the particular specimen of which the negative is desired. We are also influenced by the object we have in view.





Figure 2.  
MONARCH BUTTERFLIES ON CAT-TAILS.

*Illustrating article "Technical and Artistic Butterfly Photography."  
by Dr. R. W. Shufeldt, C.M.Z.S.*

Some photographs of butterflies are highly artistic and very pleasing in general effect, but at the same time they may be largely lacking in scientific value. If well taken, however, and of natural size, they will be pretty sure to exhibit something which will be useful and possibly valuable to the student and to the professional lepidopterist.

It is sometimes the best way to consult with critics in order to settle the question of the artistic merit of any particular photograph, of the kind now being discussed; or, better still, the average of several opinions of critics. In exemplification of this we may take Figure 2 illustrating the present article. It is a reproduction of one of my own photographs of two Monarch butterflies (*Anosia plexippus*), resting upon a cattail (*Typha latifolia*)—the so-called "tails" here being double, with one of the butterflies practically resting in the same position on each. Notwithstanding the fact that the top of the wings, or what is really the outer superior angles of the lowermost insect, are not in the picture, this composition has been much admired by several critics, some even contending that the lower insect, not being fully within the limits of the picture, is a bit of artistic license that is highly pleasing in its effect.

Now, I captured these two butterflies in one of the most glorious fields of Golden-rod (*Solidago*) in Maryland that I have ever seen in my life. Many "Monarchs" were resting here and there on the flower-tops of these elegant Golden-rods, to the number of three or four, in some instances, on each. Having, with my wife, enjoyed the sight for awhile, I caught a couple of the handsomest specimens with my fingers, placing each separately in envelopes I carried for the purpose. Next day, in my study, they were in exactly as perfect a condition as when taken, and fully as vigorous. Fastening a piece of the Golden-rod in front of a white sheet of blotting-paper, I focussed it on the ground-glass of a 5x8 camera, with a stop next to the full opening. Then, very gently and very adroitly I induced the two butterflies to rest upon it in such a way that the sides of their wings were practically parallel to the plane of the ground-glass. In a second or two they settled themselves in normal poses, and during that time a very small stop was inserted for the exposure. Side-reflection was obtained by



Figure 3.

MONARCH BUTTERFLIES ON GOLDEN-ROD.

*Illustrating article "Technical and Artistic Butterfly Photography," by  
Dr. R. W. Shufeldt, C.M.Z.S.*

another sheet of white blotting-paper. When satisfied as to the light, I made an exposure of fifteen seconds, using a blue-label Hammer instantaneous, and the result is reproduced in Figure 3,—a far more pleasing one to me than what we have in Figure 2.

For many years I have published butterfly pictures uncolored, having made no attempt to color them until the spring of 1915, when I commenced to do so, using for the purpose the now celebrated "Peerless Japanese Transparent Water Colors," which are self-blending, and in every way suitable for the work. They give a great range of colors and tints, and with a very little practice satisfactory results may be obtained in reproduction by means of the three- or four-colored process. At this time I am publishing in "*Blue-bird*" of Cleveland, a series of articles on the "Eggs of North American Water Birds." The plates which I make are from photographs of the actual specimens, and I color them with these Japanese transparent water colors. Reproduction is by the four-color process, and the last results have been remarkably satisfactory. Some of the reproductions are so perfect in the matter of color, form, and size, that they resemble the originals with great fidelity, and are really very beautiful and attractive objects, especially those possessing unusual ground colors as well as markings of bizarre designs and characters.

Not long ago I captured a fine male specimen of the sub-specific form of the Ajax Swallow-tail butterfly (*Papilio ajax marcellus*). It was taken on the Maryland side of the Potomac River, at Great Falls, and it was a most perfect specimen. Next day I made several negatives of it (5x8), and a photograph from one of the best of these is here reproduced in Figure 4. This, it will be seen, was so admirably adapted to coloring with the Japanese colors that I finished one up in that way not long afterwards. As this has been very well spoken of by a number of competent judges, I decided to use it in the present connection, and it is as Figure 4 here reproduced as much like the original as modern photographic art can make it. It will be noted that the specimen is in perfect condition and not mutilated in the slightest degree. This is unusual for an *Ajax*, for the pair of long "tails" to the inferior wings are easily broken off, either during capture or afterwards. It has

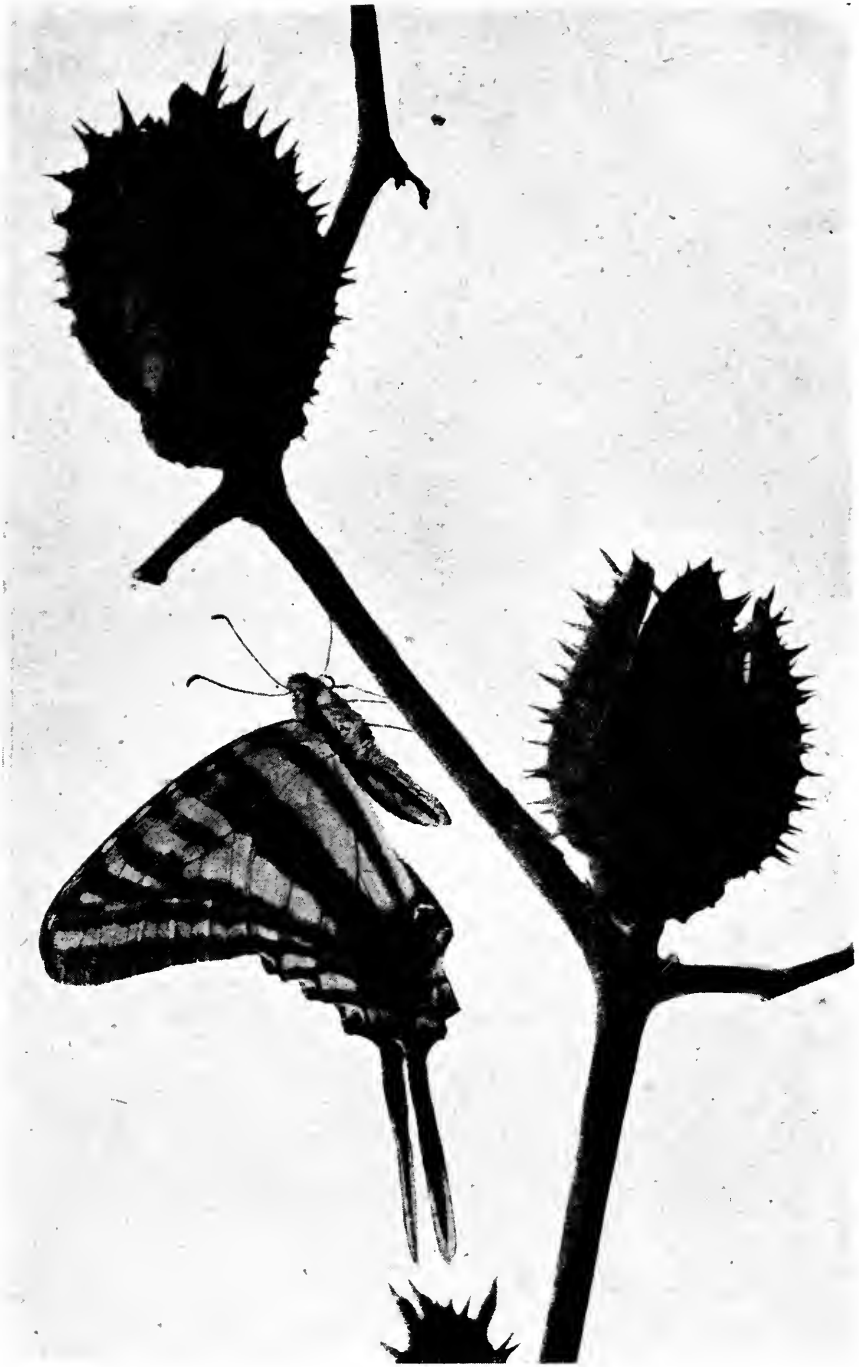

Figure 4..

THE AJAX SWALLOW-TAIL BUTTERFLY.

*Illustrating article "Technical and Artistic Butterfly Photography," by  
Dr. R. W. Shufeldt, C.M.Z.S.*

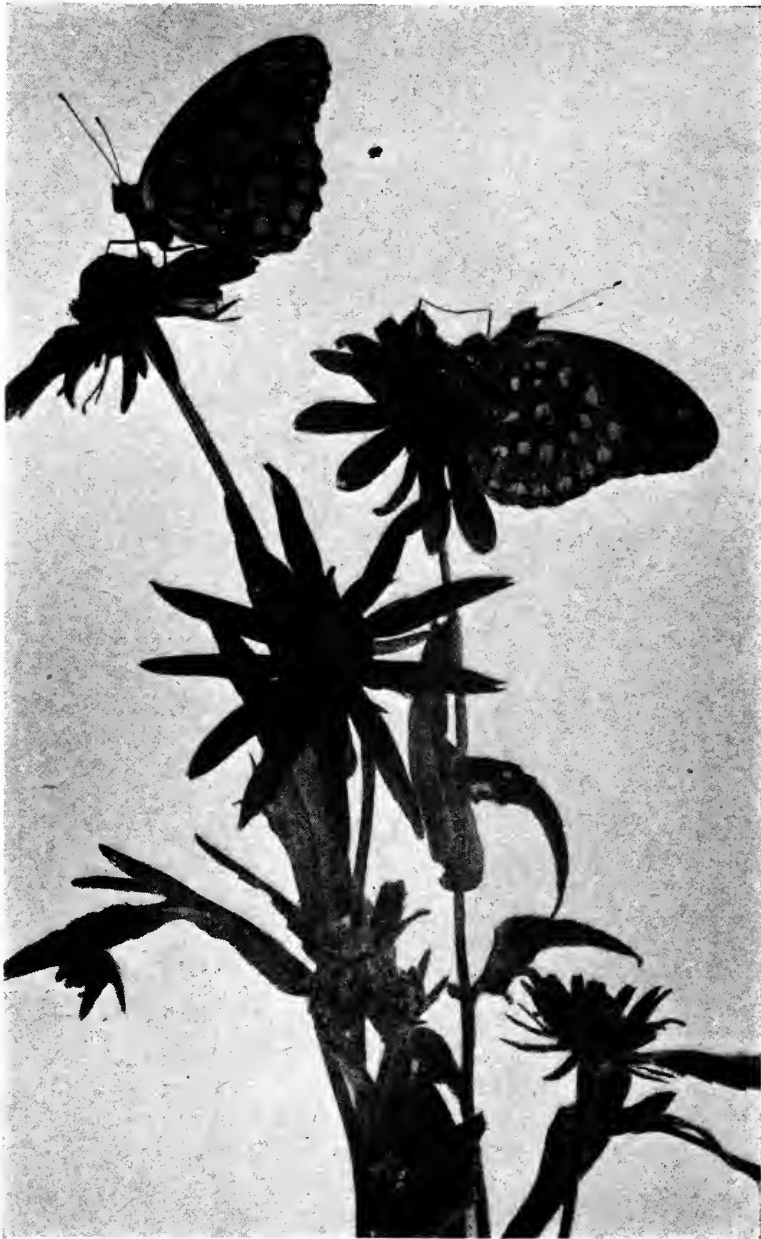

Figure 5.

APHRODITE BUTTERFLIES ON BLACK-EYED SUSANS.

lit on a stem-branch of the Jimson Weed—one that had gone to seed. This beautiful insect is not uncommon in the immediate suburbs of Washington and the adjacent country, though perhaps not as abundant as its cousin, the familiar big, yellow and black fellow, the common Tiger Swallowtail (*Papilio turnus*).

Sometimes we meet with butterflies that, when they alight.



Figure 6.

THE SHOWY LITTLE BALTIMORE.

have the habit of raising the abdominal part of the body up between the inferior wings. An example of this is seen in Figure 5, which presents a pair of Aphrodite butterflies (*Argynnis aphrodite*), and which I photographed during the summer of 1915 on a beautiful specimen of the common Black-eyed Susan (*Rudbeckia hirta*). This is a very nervous species of butterfly, and takes flight when you least expect it—

a fact to be looked out for in that a plate may not be spoiled.

An artistic as well as useful result was obtained when, the other day, I succeeded in obtaining a good negative of the Baltimore butterfly, here reproduced in Figure 6. It is a brilliant little species, and this is the first and only specimen I have ever captured of it. It likewise is very restless and nervous—that is, after being taken captive. This one flew to a window more than *thirty times* before I could get it to rest peacefully on the leaf, where I finally succeeded in making an exposure upon it. The position it occupies on the plant in Figure 6 nicely balances the picture, and at the same time it gives all the details of coloration to be seen upon that aspect of the uplifted and closed wings.

Another good catch is seen in Figure 1, one of the large, black swallow-tail butterflies so abundant in the fields during the summer months in all of the North Atlantic States. The point to observe in this photograph is that I have intentionally allowed the flowers of the plant to show above as well as below the insect, while the latter rests upon them in a *diagonal position*. Had the flowers not shown above, and had the transverse diameter of the superior wings been perpendicular to the side of the plate, the composition as a whole would have lost fifty percent of its artistic arrangement—indeed, it would by no means have been a pleasing result.

These are some of the points one must keep in mind in order to secure photographs of butterflies really worth the while.



NATHAN R. GRAVES.





EMBARRASSED.

*Copyright, 1916, by W. B. Poynter.*

# A PHANTASY ABOUT COLOR-PHOTOGRAPHY AND COLORS

By JOHN LEWISOHN



IDEAS come faster than we can execute them, if executed they can be; and while I have shown in the preceding two *Annals* of 1915 and 1916, by describing two new processes invented by me, how I have put my new ideas into concrete form, I will now in the following lines wander into the world of imagination.

Photography is so wonderfully interesting because there is such a large variety of knowledge connected with it, and then again it discloses things that we do not know. There are sciences connected with photography, there is physics (optics), chemistry, then mechanical devices (cameras and accessories and other utilities for photography), then art, and after all that knowledge there are mysteries in photography which are continually surprising and show us things that we would otherwise not perceive, and finally there are so many things that are left for the future to discover new things in photography, new things for us, but really old, only we do not know them, although they exist and this especially applies to colorphotography.

In the early time of photography it was thought that photographs would show the colors of objects, and in fact there was more done in real direct colorphotography then than ever since that time, with the exception of the Lippman process. There was a long interval between then and now when there was hardly anything produced in the work of colorphotography. Recently the subject has been taken up with more zest, but the photographs in colors produced today are not like in the earlier days done by optical and chemical action alone but with the additional aid of a mechanical means, i.e. by employing artificial colors either as a means of colorfilters through which the colors of nature are filtered, or of coloring the final photographic medium (plates or paper) with actual color-



LAKE SAN CRISTOVAL, COLORADO.

GEORGE L. BEAM.

material or both. While the results are beautiful the final resultant pictures are produced partially only by the photographic process, the other part is mechanical and being partially mechanical, the final picture can never be an absolutely true one of the colors of nature, although of course they can and do come very near to truth, showing especially the colors in their relativeness to each other.

But to come back to the old times in photography in colors and applying thereto the new ideas in colorphotography, the question is, could not perhaps in that way the secret of real or at least more real colorphotography be solved? The means by which this might be accomplished must of necessity be speculation at present. The most direct way, of course, would be to reproduce a colored object direct on silver emulsion plates or paper in colors instead of in monotonies or black as is done now. It is well known that the salts of silver assume different degrees of color from white to yellow red and blue to almost black when exposed to the light, this without adding any chemical developing agent.

Furthermore, the colored object facing the camera to be photographed is seen in all its true colors on the ground glass of the camera. If therefore a final colored reproduction is not obtained might not this be due to the developing agent, which of necessity must be employed on account of the present day method of making negatives instantaneously. Perhaps even direct colored positives could be obtained by a different silver emulsion and a different developer.

Some of the developing agents presently known are of an anorganic nature, but most of them are organic. Of the organic ones there are a large number of hydrocarbons which are mostly obtained from benzol and its derivates, aniline. Now from aniline the most beautiful colors are obtained by chemical process, could not perhaps the different compositions of the silversalts caused by the exposure to different degrees of light and colors decompose or form a chemical combination with aniline or a similar substance in such a way, so as to cause different colors to be created? Incidentally from the point of view of colorcreation, is it not peculiar that aniline, from which the most beautiful colors are produced, is obtained from coal tar which is a product of coal and that these



FOR ME THE BIRDS COME OUT TO SING.

Kate Smith.



colors are created from a substance which in its original state is black? And yet the physicists designate while naming "white" as the combination of all colors—"black" as the absence of all colors.

Now if instead of the direct way, the indirect way that of using color screens, should be employed, might not this method be changed from using color screens as made at present from artificial color material, to more natural color screens produced from the salts of silver? It is peculiar that the color screens, as at present employed, consisting of an aggregation of minute particles dyed in colors to represent the primary colors which are either irregularly constituted when incorporated directly in the photographic plate or in regular forms in the separate screen method, have very often the chocolate or other similar colorations, resembling the colors of silver salts after exposure to light, for instance like Cary Lea's photosalts which he employed in his days, to obtain colored pictures.

Another and perhaps still more natural material to be employed for color screens suggests itself if we consider that instead of using artificial material for screening the natural colors (which by the way must of necessity be always to a certain extent incorrect), a material could be used which produces the real spectrum colors. This could perhaps be accomplished by using pulverized glass which is of such a nature as to disperse the light in a high degree.

This pulverized glass might be put on a plate of glass in the form of an emulsion and then this plate may be used as a separate screen or the pulverized glass or some such similar light dispersing material might perhaps even be applied on the same plate as the silver emulsion, underlying same in another emulsion the same as the colored grains and similar to the present day photographic plates that are used for colorphotography which would then be manipulated in the same way or to go still another step further the screening material being powdered glass instead of artificially colored powder and not being affected by any of the subsequent manipulations in the development the powdered glass might be directly and intimately mixed with the silversalts in an emulsion and this might be the means to obtain a picture in the perfectly true colors of nature. Instead of glass as a support other materials might be em-

ployed, perhaps even paper, and if the picture could be produced in this manner on paper, that of course would be the accomplishment of the final end sought.

But this idea suggests another one, and that is, that instead of using pulverized glass or some such light dispersing material in connection with the silver emulsion, the silversalt itself might be formed into a crystalline and transparent light dispersing material perhaps by melting and crystallizing or by the wet method, crystallized from some solution and in this form made into an emulsion with some binding material like gelatine or other similar substance. This would be especially useful if it should be used on paper as a base, and in this way the very best results of real colorphotography might be attained.

But even if the present day method of filtering the natural colors through filterscreens should be employed, might it not be more advantageous to use pulverized *colored glass* (colored by metals or earths melted and dissolved in the glass) as the screening substance for the three primary colors instead of as now artificially colored organic material such as starch grains or similar material. The evident advantage would be that this material would be indestructible by light and chemicals and more transparent, and therefore would result in a more permanent and perhaps finer color rendering of the final picture and which, on account of the superior transparency mentioned, might be practically applied in the form of an emulsion on paper as a support with the object of obtaining a final colored picture on paper.

Finally might not the most direct of all processes of obtaining colored pictures be to employ chlorophyll, the green coloring matter of plants, as the sole medium instead of silver-emulsion or other similar photographic substances as now employed. As we see all the colors of the spectrum represented most beautifully in innumerable variety in the flowers and even fruit of nature does it not look plausible that the foundation from which all the flowers bud and develop, the stems being green, that the green chlorophyll is the foundation of all the colors?

We know that the light of the sun plays the most important part in the development of all plants and together with the chemical influence of the surrounding atmosphere and of their



productive soil makes their development possible and produces out of a green chlorophyll foundation all the most beautifully colored flowers of nature. Would it therefore not perhaps be possible by studying the conditions under which these colors are produced in the flowers from the original green chlorophyll by nature, that similar means might be employed to decompose the chlorophyll in such a way so as to obtain all the colors of the spectrum. It should be easier even than obtaining Aniline dyes out of black coal, this coal being the final product of originally green vegetation changed by ages of compression in and by the earth's crust.

The above are only observations, perhaps with some, perhaps with little value, but if we never think about things we cannot get ideas, many hypotheses have been erroneous in science, but sometimes have been the means to be a stepping stone to progress, while many hypotheses have appeared to be startling, yet they have been proven to be means of the correct solution of the result to be attained. We can only try, and if we should be wrong there is nothing lost, while we might gain, we simply have to continue until we succeed.



LANDSCAPE.

JOHN E. BOULTENHOUSE.

## PICTORIAL SEPIA PRINTS ON JAPANESE TISSUE

By G. ARTHUR TUTTLE



PRINTS from any size negatives may be made, but I find the most satisfactory results are obtained from 5 x 7 or larger. I have made very pleasing prints from  $2\frac{1}{4}$  x  $3\frac{1}{4}$  negatives, but it is best to make an enlarged negative and work from that.

There are different methods of making enlarged negatives according to the apparatus a person has at hand.

My method is to make a contact positive on a lantern slide plate or film, and then in an enlarging lantern make another negative of the desired size on a very slow plate. This allows considerable work being done with a retouching pencil and knife if the worker is skilled in that direction.

The Japanese Tissue may be purchased from most any artist supply house at a few cents a sheet. I buy 11 x 14 size which will cut to 5 x 7 with very little waste.

Formulæ for the sensitizing solution have been published in different photographic magazines from time to time, but I think the most economical for the average amateur worker is to buy a prepared solution.

I have found that Soline, manufactured by Burke & James, of Chicago, is a very simple solution to use and it gives a cold sepia tone that is most desired in this line of work.

To sensitize I lay a sheet of the tissue on a perfectly clean piece of glass and spread my sensitizer on with a large camel's hair quill brush, or a piece of sponge fastened to a stick will work very well. Care must be taken to use a brush that has no metal on it as metal coming in contact with the sensitizer oxidizes it and leaves a dark brown stain that cannot be removed.

I usually prepare one dozen sheets at one time and hang up to dry with wooden clips.



Figure 1.

IN FAIRY LAND.

*Illustrating article "Pictorial Sepia Prints on Japanese Tissue," by G. Arthur Tuttle.*

After drying, the tissue may be packed in black paper and kept in a dry place, as it will work all right after being kept several weeks.

Complete directions come with every bottle and with a little practice very pleasing results may be obtained as may be seen by the prints accompanying this article. (Figures 1 and 2.)

In mounting different effects are obtained by first mounting on colored paper such as red for sunsets, green for sea views, and blue for evening and moonlight scenes. The tissue being partly translucent shows just enough of the color through to give the desired tint to the picture and is then mounted on whatever colored mount best suits the worker.



WILLIAM S. RICE.



Figure 2.

ROCKY BRANCH AND IRON MOUNTAIN.

*Illustrating article "Pictorial Sepia Prints on Japanese Tissue," by G. Arthur Tuttle. (Page 188.)*



FAMILY GROUP.

Figure 1.

*Illustrating article "The Land of Make Believe," by J. A. Anderson.*

## THE LAND OF MAKE BELIEVE

By J. A. ANDERSON

**T**HIS article is written with a shade of doubt as to the character of its reception among the serious papers which, as usual, will adorn the pages of the Annual, but with a degree of assurance that it will, at least, meet with some sympathy from the feminine devotees of the lens, who are more likely than the other sex to have a pretty distinct recollection of the delights of that part of the magic country of "Make Believe" known as "Doll Land."

Though one may be absorbed in the deeper photographic mysteries he (or she) may find occasional pleasing occupation for the camera in this delectable region, provided that the visitor is able to enter heartily into the spirit of the place.

Contact with the stern realities of life is apt to blunt that



Alice Boughton.





mysterious sense which, at its best, belongs alone to the "little mother" with her doll. To her the doll, be it rag or china, and however uncouth, is a real personality, with a definite name. It becomes an inseparable companion; the object of the fondest affection. Call this trivial, if you please, or the result of childish imagination, but not so is it to the ardent little one. It is of the real world that is just opening to the growing apprehension of the youngster and supplies what becomes a treasured memory in later years.

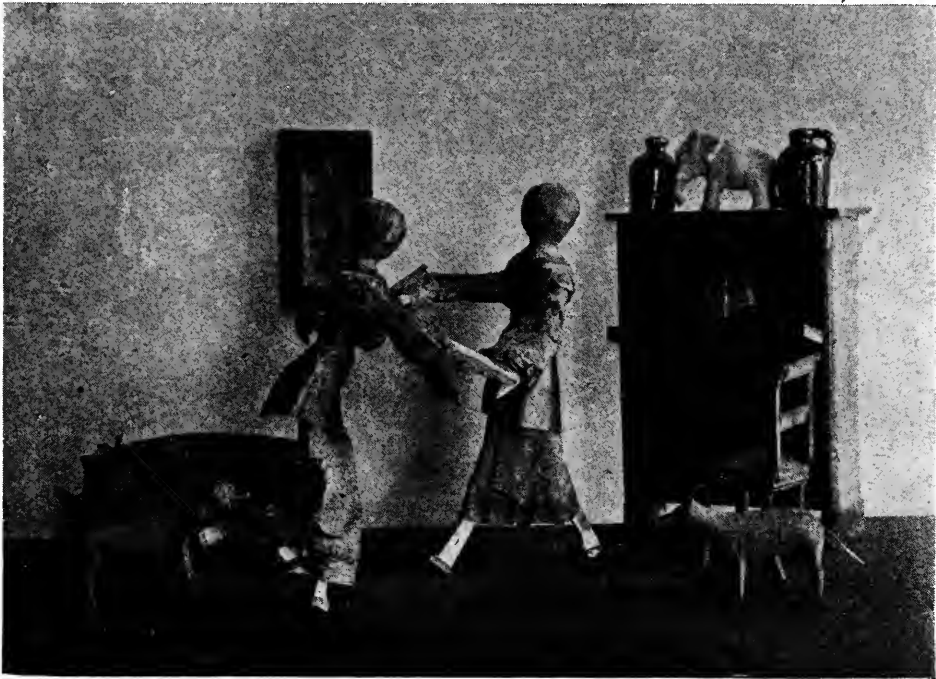

Figure 2.

GAY TIMES.

To grandmother, the ragged doll of her youth brought fond remembrance of the time when it was a cherished possession. Its presence now, a century old, constitutes, for the members of the family, a prized memento of its former owner and a pleasing reminder of their own happy time when dolls were real persons.

For the duly qualified it is but a step across the border to this magic land. The inhabitants do not object to posing before the lens in life-like attitudes. In a recent visit it was my good fortune to secure some pictures of well dressed ladies in

carriage and on foot; stately dames come out from their seclusion; dances and afternoon teas, dear to the feminine heart; and even of dogs of demeanor so demure that it gave no hint that they ever would or could "delight to bark and bite."

These productions, some of which are herewith shown, Figures 1 and 2, served with a few touches of water color, as decorations on place-cards at a Christmas dinner table, providing a pleasing entertainment for those assembled at the feast. Memories of youth were revived and strengthened; this almost forgotten country became once more a reality, and the pictures, treasured by the guests, were carefully carried to their homes.

If one of the chief aims of photography is to please, this visit to the charming "Land of Make Believe" was a success. Try it, reader, and, don't forget your camera.



THE YOSEMITE FALLS.

EDWARD S. MC ALL.



IN THE GARRET.

HERMAN GABRIEL.

## COLOR-TONING BROMIDES

By A. T. LAKIN, M.D.

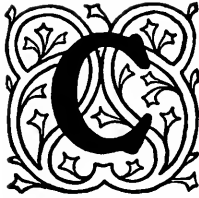

COLOR-TONING of Bromides is rather fascinating, and is simply an application of the ordinary Sulphide Toning.

*My standard bleacher:*

Potassium Ferricyanide . . . . .	300 grains
Potassium Bromide . . . . .	100 grains
Water . . . . .	20 ounces

Variations of this formula are common, the only point that need concern us, is that if the proportion of bromide is over one-third the amount of the Ferricyanide, the Sepias tend towards the Yellows.

In the portrait, that I am using as an illustration (Figure 1), the first step was to put a drop of gold toning solution on the eyes, this colors the eyes blue, when the action is seen to be sufficient, blot off. The face was then painted over with the Ferricyanide and Bromide Bleacher (equal parts of the re-agents were used to get a yellowish Sepia). This bleacher may run over the outlines. We must then re-develop with an ordinary Bromide Developer, and start afresh.

Suppose we have done this part properly, wash, and dry with blotting paper, paint a weak developer over the shadow portions, namely neck, under the eyes, junction of hair and face, and wherever we wish to avoid a hard line of color differentiation, and as soon as parts begin to develop, and as soon as we judge they are developed as far as we desire, place the whole print in the sulphide solution. Wash, and dry.

When the print is dry, then paint over the cheeks and lips with the gold solution. This must be very weak, and the painting must be done very carefully.

The colors we have at our disposal are  
Browns, obtained by variations of Sulphide toning.  
Blues, obtained by the Gold & Sulphocyanide bath.  
Reds, obtained by the Gold & Sulphocyanide bath applied after Sulphide Toning.



Figure 1.

*Illustrating article "Color-Toning Bromides," by A. T. Lakin, M.D.*

Greys, this is dependent on the color of the image by the use of weak Rodinal or Metol Developers.

Blue-blacks, color of image given by Amidol Developers.

Greens. I have not found a satisfactory green toning solution, so I avoid greens as much as possible. Vanadium is the best for this purpose, and should be applied last, and washed off as soon as the desired effect has been obtained.

The secret of success is to make haste slowly, and do it bit by bit. I dry between each color application.



EVENING ON THE HUDSON.

DR. F. T. SORNBERGER.

Enlarged from  $3\frac{1}{4} \times 4\frac{1}{4}$ , with Verito Soft Focus Lens.



JAMES E. PATON.

THE RIVER.

## A PLEA FOR THE USE OF BETTER PRINTING MEDIUMS

By LUKE R. VICKERS

URING the past Winter the writer had the pleasure of attending several exhibitions of photographs, studying upwards of a thousand prints. Among all these prints one exhibition of about fifty prints stood so far above all the others that the writer began to make comparisons to try to discover what it was that gave this latter collection such a dignified and artistic tone. The composition was not noticeably better than that of some of the other fine collections, the quality of definition was much the same. What was it that made these prints stand out above all the rest? The secret was the printing medium.

In this whole exhibition of over fifty prints there was not a single bromide print. About eighty per cent of the prints were in platinum, the others were gums and carbons. It was the wonderful quality, obtainable only in these mediums that raised them to the highest place.

Why do not people make the most of their exhibition pictures by printing in these mediums, you ask? This I can not answer. Some say it is so easy to make a bromide enlargement and that is why these are in the great majority. But is it easy? I venture to say that for every perfect bromide print exhibited five were discarded in the making. Yellow spots, blisters, grey lifeless prints and contrasty prints are a few of the troubles with which one has to contend. But take a perfect bromide print, its finest blacks can not compare with the rich vibrant black of a carbon print and the delicate, transparent shadows of a snow scene in platinum are represented by white paper in a bromide print.

These are the arguments for adopting the "noble mediums"; the arguments against them are weak, to my mind, easily refuted. One must have a negative as large as the finished print is to be. In this day of the small camera this may seem too





VIOLET ROMER.

Edward Henry Weston.



much trouble, but even if one does not make lantern slides it is well to make transparencies of one's best negatives in case the original becomes lost or broken. The transparency is as easy to make as a print; the enlarged negative no harder than an enlargement and once this is made prints can be turned out without further difficulty. One can work out defects very easily on the transparency too, and with no danger to the original negative. A soft focus lens can be used for making the enlarged negative, just as is often done in making bromide enlargements.

The technical details for gum, carbon and platinum can be found in almost any magazine file. I can recommend the "Photo-Miniature" for platinum and carbon and Mr. R. L. Anderson's series of articles in American Photography about two years back is quite the best thing I have seen concerning gum. He covers every point fully and gives some of the theory too.

A few words drawn from personal experience may not be amiss. Platinum, to my mind, is the medium *par excellence*; unfortunately it is unobtainable at the present writing. Those who are so fortunate as to possess some potassium chloplatinite can coat their own paper, but this is always more expensive than the commercial papers.

Incidentally, the most beautiful prints the writer has seen were hand-coated platinum on hand-made Japanese vellum. Carbon is easily obtained and in a variety of colors. The colors the writer finds most useful are Rembrandt sepia and engraving black. Other useful colors are, dark sepia, portrait brown, Italian green and red green. Gum is made at home very easily and cheaply. Any moist watercolors can be used as well as dry color. Charcoal grey, ivory black, lamp black, and burnt sienna are good colors. A good gum print is tedious and hard to make but once made is something to be cherished and fully repays all labor that has been spent on it. Gum prints to be most effective should be 8 x 10 or larger, the smaller sizes do not make such an effective showing.

In conclusion I shall say these processes are for the serious worker, one who spares no pains to get the most from his negatives and one to whom the pleasure of working is enough reward in itself.

## PICTURESQUE NEW YORK

By WILLIAM H. ZERBE



It has never been my pleasure to visit Europe, although the longing has many times been with me to do so, and to try for some of the many picturesque scenes which the Old World contains, I feel sure I am not alone in this longing. Judging from the many beautiful photographs shown in the magazines from time to time I do not wonder this ambition takes hold of us.

Why is it that these foreign scenes appeal to us so much? I have asked myself this question many times, and my answer is because they are different from what we are used to seeing in our own country. I feel sure that scenes from this country have just as many attractions for the people on the other side as theirs have for us.

Of late I have been making a study of picturesque New York. I have only made a start, but I am satisfied that right here we have pictorial material that is as attractive, or more so, than the Old World pictures. To make them so, however, we must treat our subjects in a different manner than we are accustomed to see them on post cards, or real estate advertisements. Building and street scenes, for instance, require some study in the selection and proper lighting, as well as taking them under proper atmospheric conditions. We see certain scenes so often that we never think to seek their pictorial possibilities.

There are hundreds of subjects which we pass daily that would lend themselves to real pictures if a little study were given to the selection and viewpoint, as well as light conditions. We too often try to include too much in our picture space, and take it at a time when we happen to be there, instead of studying our subject to find out what light and atmospheric conditions are best suited for it.

To make our pictures appeal to others besides ourselves we



A BIT OF OLD GREENWICH VILLAGE.

*Illustrating article "Picturesque New York," by William H. Zerbe.*

must make them different and treat them in an original way. Besides selection and lighting the method of printing can be made to play an important part. Some subjects may require a medium for fine detail while others may require a medium that gives breadth, or sketchy effects, such as gum, oil or carbon. The mistake usually made is to portray them in a way that is familiar to every one with the result that they do not make them appear as pictures.

If a building, do not think it necessary to include the whole of it. Perhaps a doorway, or entrance, in a vista would look better than the whole. It is not our desire to advertise the building, but to make a picture for the sake of a picture only, not caring where, when, or how it was made. If our picture space contains something that is pleasing in lines and masses, we need have no worry where the location is.

A few excursions through the city with the express purpose of hunting material for pictures has satisfied me that the pictures are here and only need our artistic ability to discover them.

A few suggestions, however, may be appreciated. Down Town we have the narrow streets and canyons. Skylines are interesting from most any point of view. Then we have the four bridges. There are still some possibilities in photographing the spans from the river front, a little different than has already been done. I think, however, there are new possibilities in the approaches, piers, and masonry work, showing the arches and vistas.

Going further up town on the west side there is Greenwich Village, which is full of pictorial material with the quaint houses, picturesque doorways, iron fences, and crooked narrow streets lined on each side with dilapidated buildings in which once resided the aristocrats a few generations back, but now occupied by foreigners most of whom still dress in their native costume.

Crossing to the east side we may also run across some old time mansions, but it is the street scenes in the Ghetto that will interest us most. In that section certain streets are given over to push cart venders who always make picturesque subjects, especially if treated in an original way.

In midtown our subjects are more modern, but full of pic-



UNDER THE MUNICIPAL BUILDING.

*Illustrating article "Picturesque New York," by William H. Zerbe.*

torial possibilities nevertheless. The public Library, the new railroad terminal, a few of the hotels, and some of the small theatres—I might mention the Little Theatre, and the Punch and Judy Theatre—as holding out some possibilities.

Further uptown we come to Columbia University Library and Grant's Tomb. Of the former I have seen several hundred different views, among which were some real works of art, and I am satisfied there are a good many more opportunities there that can be done in an original way.

In my list I have only mentioned well known subjects, feeling sure if you get started in this line you will soon discover subjects that you will be able to do in a way that will be different from the usual thing, and, therefore, be more appealing to one who likes to see real pictures.

What has been said of New York City will apply to any city or town in this country. Select your subjects, and do them different than the usual way. "Different" should be your keynote in all your work if you wish for success.



SUMMER.

E. D. LEPPERT.





UNDER THE OLD PIER,  
SANTA BARBARA, CAL.

FEDORA E. D. BROWN.

# NIGHT PHOTOGRAPHY WITH THE SOFT FOCUS LENS

By DR. W. G. ADAMS



**W**HAT amateur—and when I say amateur I mean one who has passed the movie stage—who has seen good night-pictures, say by Blake of London, or Dr. Benedict of New York, has not felt inclined to try his hand at this very interesting branch of photographic work?

The self-constituted authorities tell us that night photography has little or no pictorial possibility. Well, perhaps not all of us agree with this dictum, but suppose we let it stand. On the other hand, while pictures made at night may have little pictorial merit, it cannot be denied that they are very interesting and have a wonderful charm that is all their own.

When the struggling and perspiring (I meant to say aspiring) amateur has exhausted landscape, knows all about genre possibilities and has mastered the last word in home portraiture, he usually sits back and sighs for new worlds to conquer. I would advise such person to try night photography, and right here I would bespeak a word for the soft focus lens. These lenses hold the highest place in the esteem of contemporary workers and are just as appropriate for night work as for **day** work.

To hark back to the critics again, a picture should not say everything there is to say about the subject which is being portrayed. Some parts of the picture should be rather vague, perhaps somewhat dim; in other words, some things should be only partly revealed and not shown up with microscopic definition. This allows the mind a chance to speculate and gives the imagination a little scope.

In the broad light of day objects stand forth exposed in all their plainness and ugliness, but at night it is possible that these same objects, being dimly illuminated and only partly revealed, will be clothed with mystery. And the element of the unknown, lurking in the deep shadows, will give the imagina-

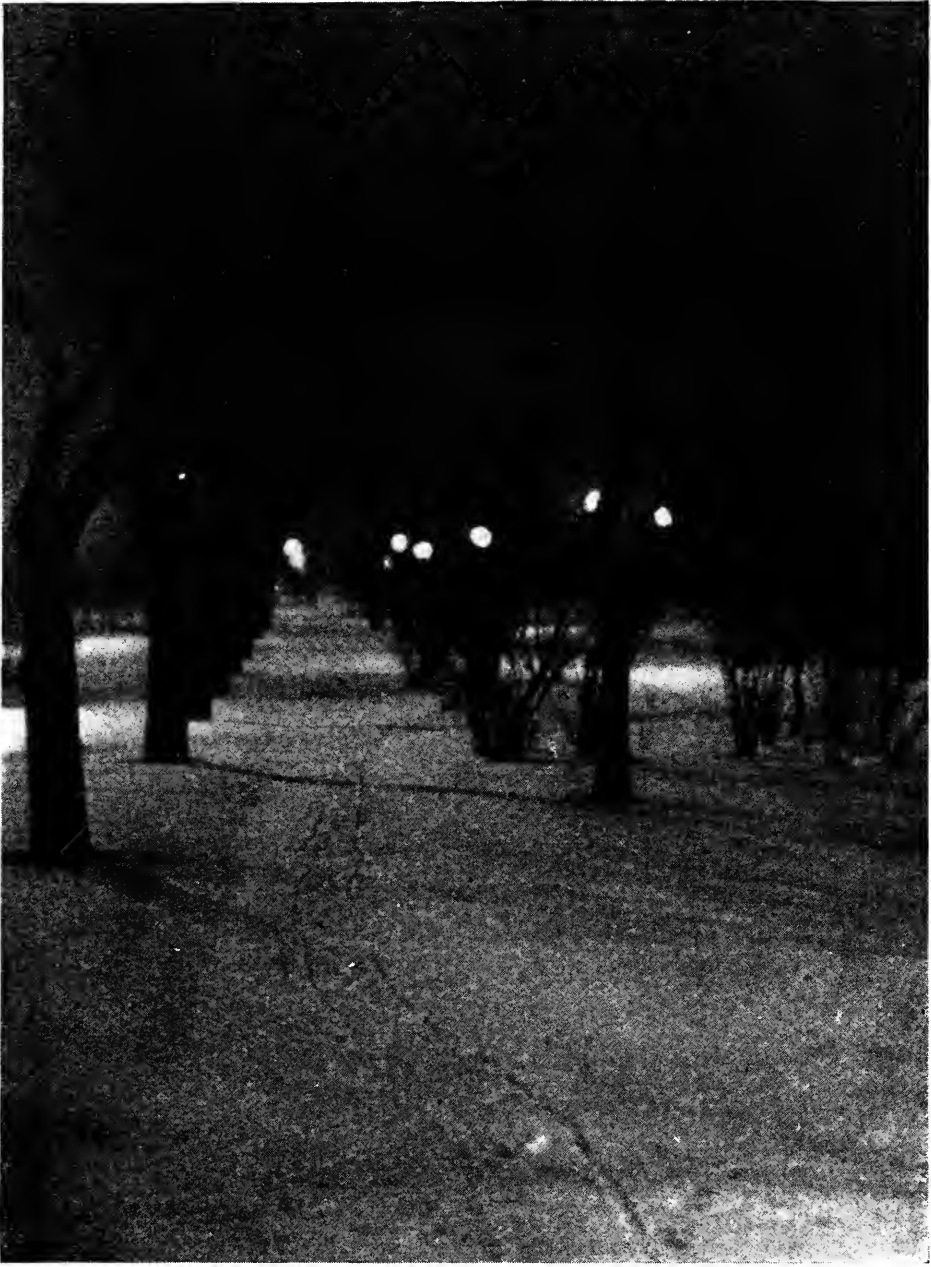

Figure 1.

*Illustrating article "Night Photography With the Soft Focus Lens," by  
Dr. W. G. Adams.*

tion a chance to exercise itself to the utmost. And so it seems to me that when it comes to giving the imagination a chance to do a few stunts the night picture is there with the goods.

But I fear I digress overmuch with matters of art so let us hasten back to our muttons.

There are several soft focus lenses on the market, some working as fast as F/4; so if a large aperture be used exposures will not be long. The night pictures which I have taken required exposures ranging from two minutes up to ten.

A bad feature of some soft focus lenses is that they give considerable flare when used on contrasty subjects—and such are apt to be encountered at night. However, I understand that one maker claims to have overcome this fault.

Halation is also quite a problem—at least when high power lights are included in the view and are rather near the camera. This can be overcome, more or less, by using double coated plates or else plates which are backed. Portrait films would doubtless give good results, but I cannot speak from experience. If one wants backed plates (I recommend the double coated plate as having more latitude) it will be necessary to buy some imported brand as they are not made in this country, or else do the backing oneself. It is my practice to use double coated plates for all outdoor work and for night scenes, if I have time. I back the plates with the following mixture:

Glycerine ..... 1 oz.

Wood alcohol ..... 6 oz.

Lampblack enough to make a thin paste. This is applied with a brush and it dries quickly, especially if there is a fire in the house.

Double-coated plates are often sufficient but sometimes a strong light will burn through both layers of emulsion and produce halation. If lampblack is used the small amount of light that gets through to the back will be absorbed.

I trust I have convinced a few that the “mystery rendering, angle softening” soft focus lens is well adapted to night work and that we will see some examples in future issues of the *Annual*.

As an illustration of what lampblack will do I refer to Figures 1 and 2. Figure 1 was taken at 10:30 P. M. The ex-



Figure 2.

*Illustrating article "Night Photography With the Soft Focus Lens," by  
Dr. W. G. Adams.*

posure at F/5 was five minutes and the double-coated plate was backed.

It will be noticed that there is no halation around the street lamps and they were very brilliant. Figure 2 was taken the same night. The exposure at F/6 was six minutes, and the double-coated plate was not backed. Two lamps show considerable halation.



CORRIDOR, CONGRESSIONAL LIBRARY,  
WASHINGTON, D. C.

E. J. BROWN.



DEEP GLACIER VALLEY, ALASKA, NORTHWARD BY  
MILES 47 TO 51, HARTLETT GLACIER VALLEY.

P. S. HUNT.

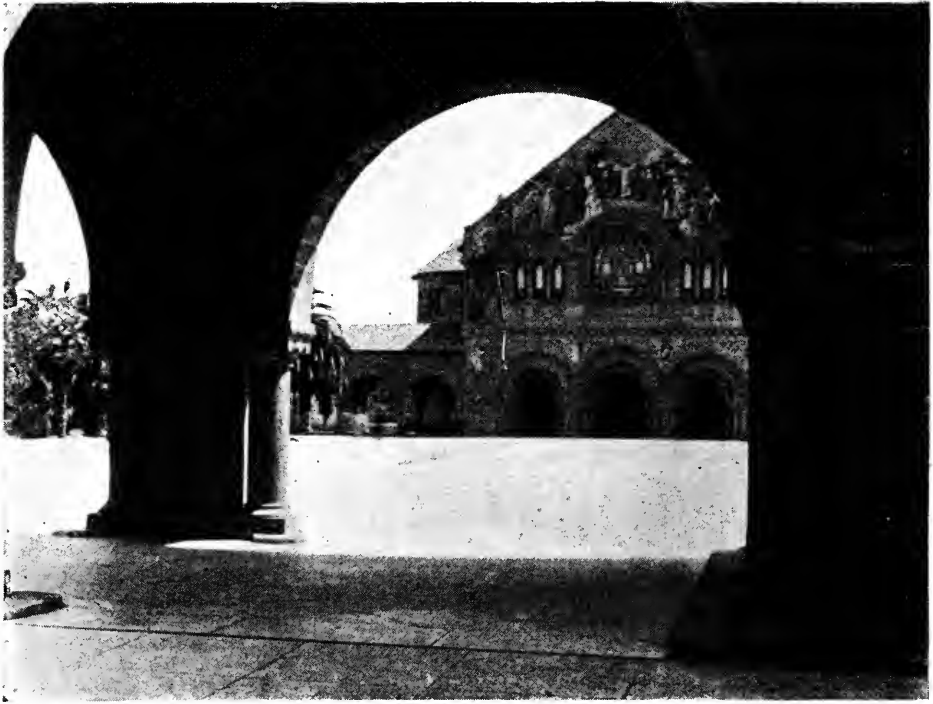

Figure 4.

*Illustrating article "The Needlehole in Architectural Photography," by A. M. Sutton, M.D.*

## THE NEEDLEHOLE IN ARCHITECTURAL PHOTOGRAPHY

By A. M. SUTTON, M.D.

**I**T is a fact that needlehole or lensless photography does not appeal to the average kodaker, but it is also true that most of us were in that class once and graduated from the kindergarten of the snapshot. Of course to one who owns only a roll film camera lensless photography, in common with other work of a more or less serious kind such as flower pictures, nature study, and so on, is hardly practicable. But the outlay required to purchase a second-hand plate camera is small in these days, and such an outfit is just what is needed if one is minded to branch out from the beaten highway of the brilliant finder and the T. I. B. shutter—with the accent on the I.





A SUMMER LANDSCAPE.

M. MACKINNON.



Figure 1.

It is not part of my purpose to enlarge upon the general character of the lensless image or its application to landscape work. Nor can I go into the matter of the making of needle-holes further than to say that any small carefully made hole in very thin metal may be successfully used in place of a lens; and that the more perfect the hole and the thinner its edges the better the results will be. Numerous expert articles upon the making and use of the needlehole have appeared from time to time in the magazines and annuals, and to them I must refer



PORTRAIT.

S. Withrington Stump.



the reader in search of further detail. It is much to be regretted that the two best monographs on the subject, Nos. 27 and 70 of the Photo Miniature, have long been out of print and are hardly procurable at the present time.

From the standpoint of architectural photography, or the portraiture of buildings, the most important quality of the needlehole image is its geometrical accuracy. Provided that the camera is set level, be the angle of view wide or narrow the perspective will be absolutely true. As a rule in architectural work one must use a wide angle lens quite frequently, and in that case more or less exaggeration of perspective is inevitable.

With the needlehole, be the field of view ever so wide, if the camera is properly placed the lines will fall in just as they ought. And the angle included on the plate may be varied at will without necessarily moving the camera. By simply increasing or diminishing the distance between needlehole and plate either magnification or wide angle effect may be had at will, and in both cases with perfectly rectilinear results. Further, the depth of focus is infinite; no blurring of foreground or distance can occur, but the same soft natural definition all over the plate, and in addition the highest degree of atmosphere and sense of distance.

The illustrations to this article were all made on the campus of Stanford University, California, in strong June sunshine between 10 a.m. and 3 p.m. For pictorial reasons I would far rather have made these exposures earlier or later in the day, but circumstances compelled me to utilize what time I could. An ordinary 4 x 5 plate camera was used with unbacked Defender Ortho plates, not the double coated kind. No lens was employed except as a finder for the needlehole image which of itself is too faint to be recognized on the ground glass. My needlehole is about 0.375 m.m. diameter pierced in a bit of sheet brass 0.2 m.m. thick by a No. 11 Milward needle; the metal forming the edges of the hole being rubbed down to a thinness of 0.1 m.m. or less, and all trace of burr or irregularity removed so that the hole will pass inspection under the 1 in. objective of a microscope and appear perfectly round. The piece of brass containing the hole is then fastened down to a piece of black card, which has a perforation about  $\frac{1}{8}$  in. diameter in the middle so that the needle-

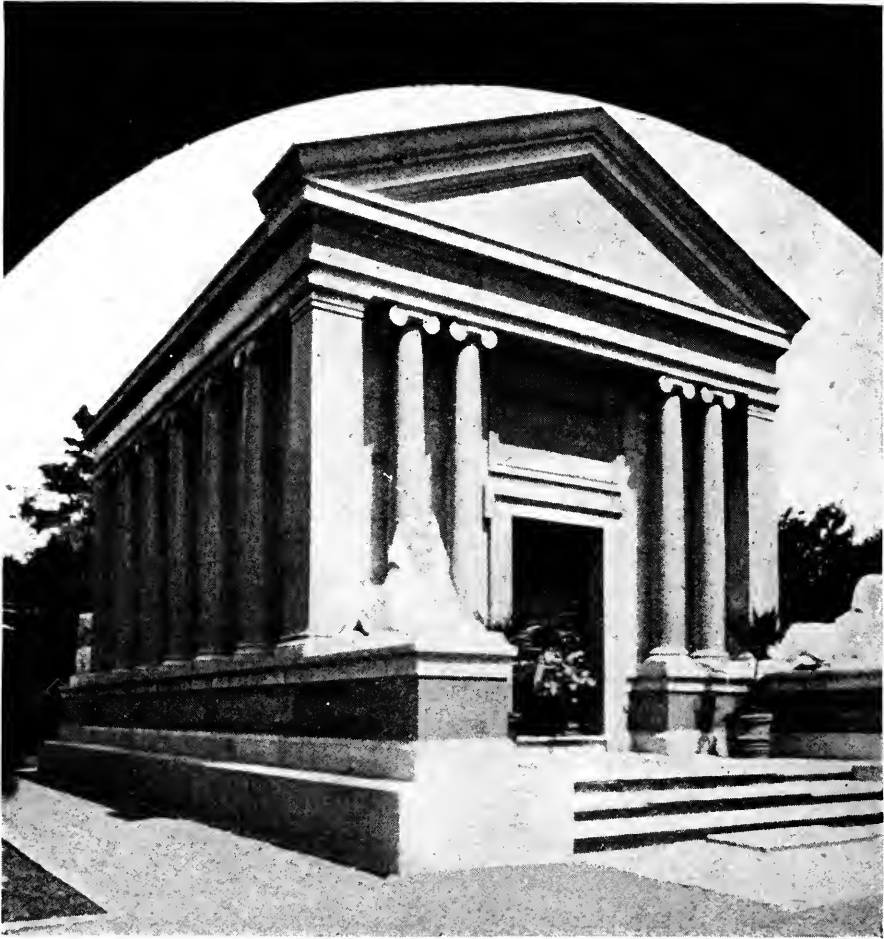

Figure 2.

hole centers; and the card is then cut out so as to center into a spare lens mount, and is secured there. Of course the needlehole and the brass surrounding it are carefully deadblacked. To return to the camera, my method is to remove from the shutter both combinations of the R.R. lens normally there, replacing the empty shutter on the lens board. I have two spare lens mounts which fit the front end of the shutter; the first contains an ordinary spectacle lens of 8 in. focus; the second my needlehole mounted as above described. I first place the spectacle lens in position in the front of the shutter just as if I were going to make the picture with it; open up the diaphragm wide, set the shutter at T. and open it, and proceed to compose the picture on the ground glass. If



THE OUTLOOK.

HAROLD CAZNEAUX.

the composition suits me at the focus of this lens I let it go at that; but if I think I need a greater or less angle of view I rack the bellows in or out as required. This, of course, blurs the image but leaves its general outlines distinguishable, unless a very short, or an abnormally long, extension is needed. In the former case I hold another unmounted spectacle lens im-



Figure 3.

mediately in front of the one already in position, which reduces the focal length to about 4 inches. In the latter I use in place of the spectacle lens one combination of my R.R. lens which has a focus of about 11 inches. Having composed the view I remove the lens used as finder and screw in its place the mount containing the needlehole, close the shutter, insert the plate holder, and make the exposure in the usual manner.



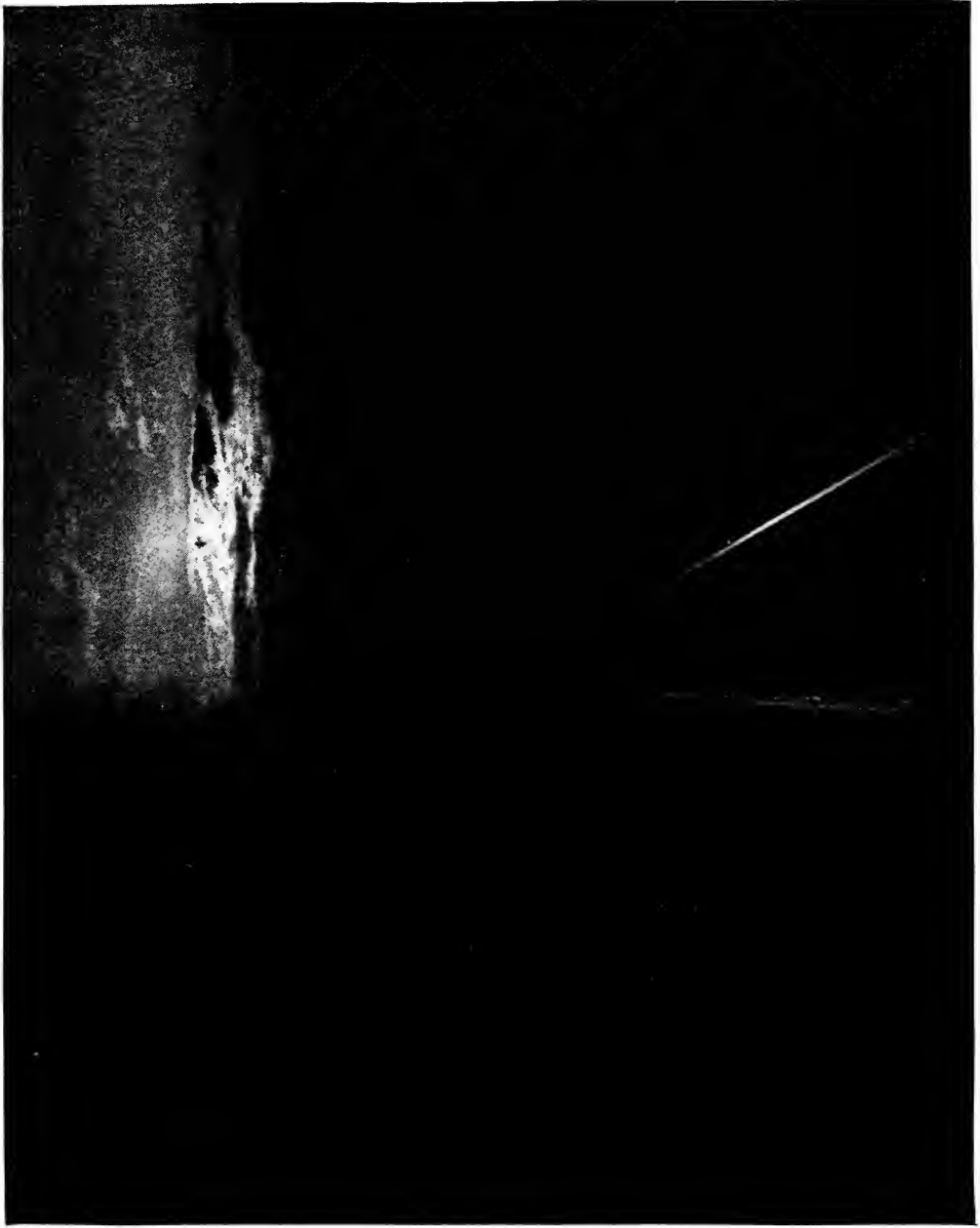

THE TRAIL OF THE EMPIRE STATE EXPRESS.

S. P. EMERICK.

Figure 1 is the Lathrop monument, Stanford's famous "Angel of Sorrow." This is shown as an example of the definition yielded by a well made needlehole. It may not be critically sharp, but I submit that it is sharp enough to absolve lensless pictures from the charge of fuzziness. In this case the distance between needlehole and plate, hereafter abbreviated as p.d., was 8 in. and the exposure 30 sec.

Figure 2 shows the tomb of the founders of the University, Senator and Mrs. Leland Stanford. Figure 2 was made with the camera only twenty feet from the corner of the building with a p.d. of  $3\frac{1}{2}$  in. and an exposure of 10 sec. The black cut off at the top clearly shows that the method of using the camera with the shutter in position as described above is a mistake; for it was the back portion of the shutter which cut off the light in this extremely wide angle view. Both the finder lens and the needlehole should be so arranged as to screw directly into the lens board without the intervention of the shutter, and exposure made with a cap. With such an arrangement Figure 2 demonstrates that, using a reasonable amount of rising front, a building may be successfully photographed when the camera is placed at a distance from the building which is less than the height of the building itself; a valuable property where space is limited as in the streets of a town.

Figure 3, a general view of the University Chapel, was made with a p.d. of 8 in. exp. 30 sec. Although the sun was in an unfavorable position the beautiful colored mosaic of the gable shows up remarkably well; in fact quite a little better than the result the average tourist gets.

Figure 4, another view of the chapel through the cloister arches, p.d. 5 in. exp. 45 secs. This print demonstrates another remarkable property of the needlehole image. It will be noted that an unbacked plate was used, and the shadows show that the bright sunlight was well ahead; and yet there is an almost entire absence of halation. Dr. D'Arcy Power in his masterly monograph upon this subject lays special stress on this quality, and shows a remarkable print of a plant in a pot photographed right in front of a window with a lace curtain intervening. The exposure was long, 10 min., yet the sash bar



THROUGH THE CABLES OF BROOKLYN BRIDGE.

BLANCHE C. HUNGERFORD.

comes out quite clear and the pattern of the curtain is beautifully defined against the strong light from outside.

Figure 5. A close up view of the chapel entrance, p.d. 7 in. exp.  $1\frac{1}{2}$  min. This is a good example of the perfect perspective of the needlehole image under somewhat difficult circumstances. If any one doubts the difficulty, let him just go out after a subject of this nature with an ordinary equipment and just a lens, and I think he will appreciate it to the full.

By the way I would like to say that this Figure 5 makes a particularly fine enlargement to 11 by 14 for framing. It has been said that lensless negatives are not suitable for enlargement. I think the same rule applies as with the orthodox kind; some are eminently suitable and others are not. The peculiar soft definition of the needlehole image is certainly no bar to successful enlargement, but rather in many cases an enhancing quality.

It will be noticed that in some of these prints of mine all the lines of the buildings do not fall exactly true if measured up accurately. It is difficult if not impossible to accurately level up a camera only provided with the ordinary small spirit level in general use; hence some discrepancies. But my object was rather to show what can be done with a very ordinary outfit than to attain any degree of mathematical accuracy.

In this article it has been my aim to treat lensless photography from the point of view of architecture, but the method has unlimited application in every branch of our art where the effect desired is of a pictorial nature. Of course one cannot do speed work, night, or flashlight photography without a lens; but there are other large fields where the results are eminently satisfactory.

I will close with a quotation from the Rev. J. B. Thompson, one of the pioneers of the method. He says, "in a good needlehole photograph it is not too much to say that we have an effect much nearer to nature. If we have not every object far and near presented with the same minuteness of detail that we mentally know the objects to possess, we have much more nearly the vision which actually meets the eye. We have atmosphere and the right impression of distance. And, what is still more important, we have what we may call plastic



WOODLANDS.

Theodore Eitel.

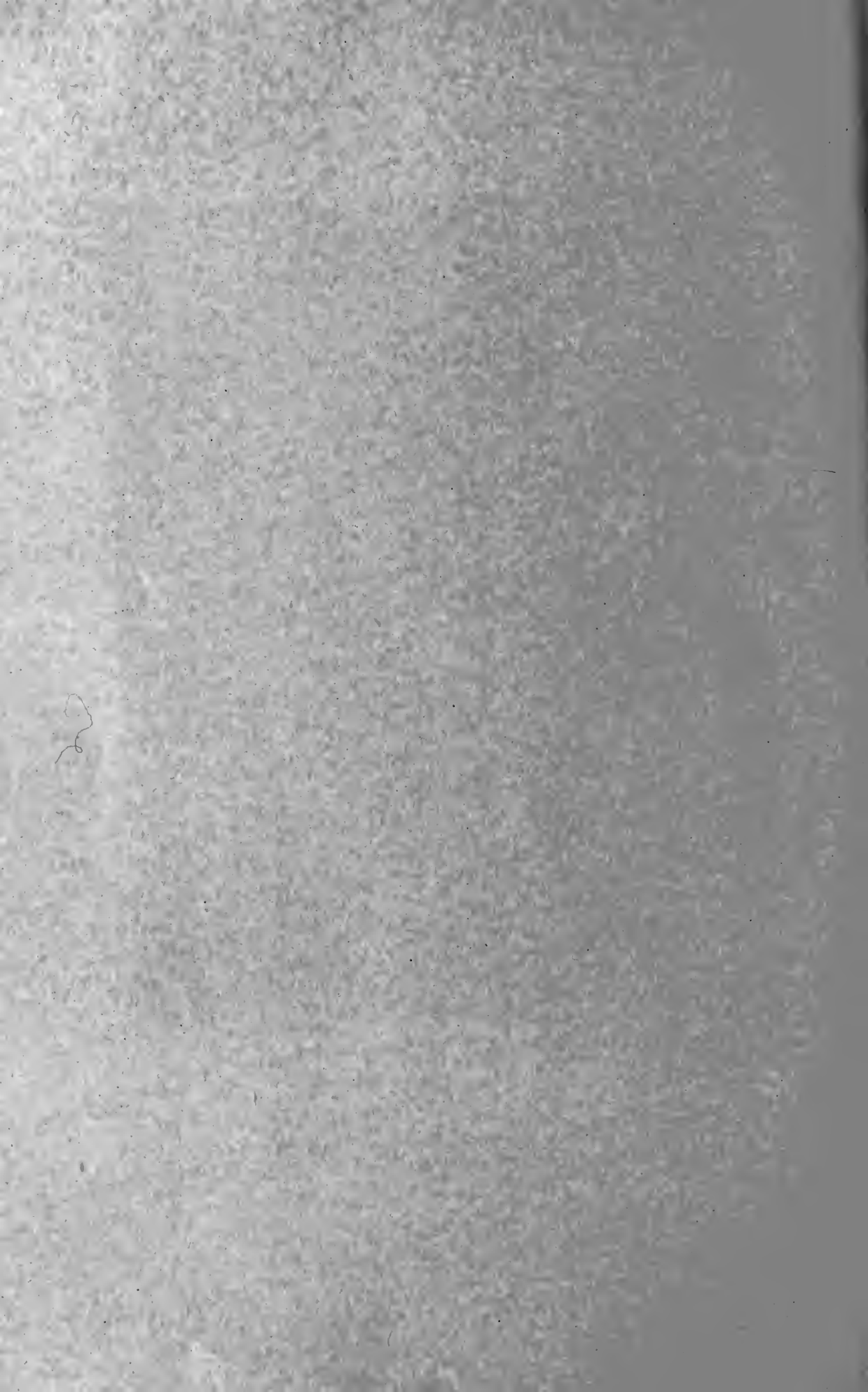

quality, that quality which makes objects stand out bodily and not merely appear on the flat. The picture suggests much more to us just because it does not pointedly express everything, and we can look at it again and again with the feeling that we have not seen all that is in it."

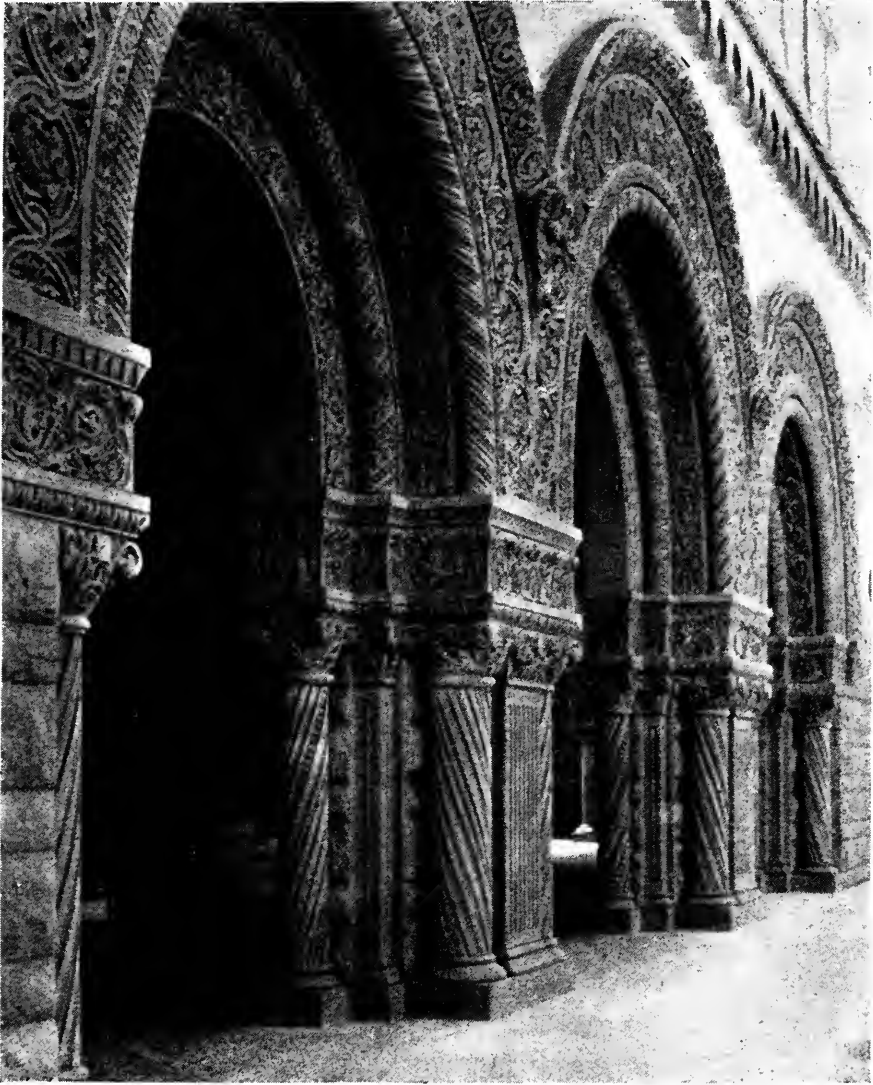

Figure 5.

*Illustrating article "The Needlehole in Architectural Photography," by A. M. Sutton, M.D.*



Figure 1.

CHITTENANGO FALLS.

*Illustrating article "Photographing Waterfalls," by Harry G. Phister.*

## PHOTOGRAPHING WATERFALLS

By HARRY G. PHISTER

**T**o the photographer, and especially the amateur, a waterfall is always an attractive subject, but one of the most difficult to photograph satisfactorily. Located, as they usually are, between high banks covered with vegetation, of a non-actinic color, it is next to impossible to photograph them, in the usual way, and obtain detail both in the water and the dark wooded banks. An exposure sufficiently short to show detail in the water would only result in inky black banks, in the resulting print, while an exposure long enough for the banks would render the water blurred and without detail.

I have found it very satisfactory to give an exposure sufficiently long to secure detail in the darkest portions of the view, but instead of giving one prolonged exposure, I set the shutter at  $1/25$  second—this being the speed which renders water, in





CLOSE OF A NOVEMBER DAY.

HARRY G. PHISTER.

motion, in the most satisfactory manner—and snap it a sufficient number of times to secure the correct exposure. Of course a tripod must be used and care taken not to move the camera between exposures. The slight over-exposure of the water does no harm but, instead, it tends to reduce the excessive contrast and produces a more harmonious picture.

I have to thank the Eastman Kodak Co. for this tip which was given in their advertisements a few years ago, but I am inclined to think it is not used as much as it should be.

The two reproductions given herewith will serve to illustrate the advantage of this method of exposure as you will find abundant detail over the entire prints with no blurring of the water.

The negative of Chittenango Falls (Figure 1) was given  $20/25$  seconds given in  $1/25$  second intervals, and the one of Fairy Falls (Figure 2)  $10/25$  in the same manner.

It is best to use as large a stop as possible and thus reduce the number of separate exposures.



Figure 2.

FAIRY FALLS

*Illustrating article "Photographing Waterfalls," by Harry G. Phister.*

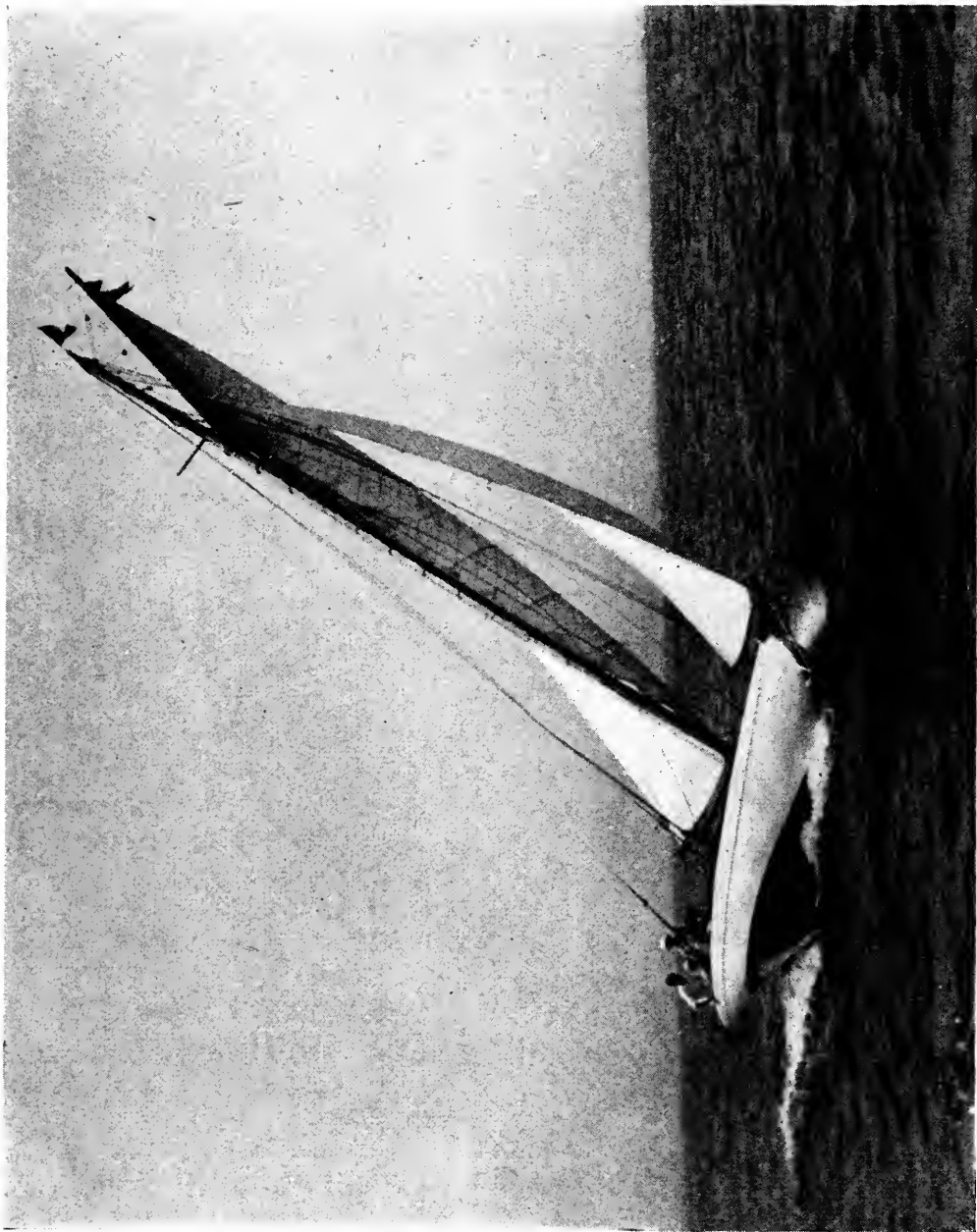

MISCHIEF II.

W. C. SAWYER.

## STEREOSCOPIC PHOTOGRAPHY

By E. J. WALL, F. R. P. S.

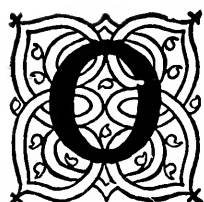

Of all processes stereoscopic photography gives the most wonderful results. One has, if properly carried out the most perfect illusion of relief. It is by no means a difficult process and the following notes if followed will enable anyone to turn out perfect stereoscopic pictures.

The size of the plate is the first question, and this is to a great extent a matter of personal choice. Personally I prefer  $3\frac{1}{4} \times 6\frac{1}{2}$  inches, which can be easily carried in any 5 x 7 plate holder, if kits are used.

The camera must be provided with a central division and twin lenses. The division can be made with a piece of black rubber cloth, which must be sufficiently long to extend from the inside of the lens board to the focussing screen, when the bellows are extended to their fullest extent. At the same time it must contract with the shortening of the bellows. The easiest way to make this is to obtain a stout steel or bone knitting needle, cut to the proper length and wrap the cloth round quite tight and cement with a little cycle tire cement. Two small wire hooks should be driven into the back of the lens front and to the inside of the frame of the focussing screen, the knitting needles can then be readily slipped into these hooks. At the top and bottom of the cloth should be sewn two narrow strips of elastic, which will naturally contract and expand.

The lenses must be paired, and an important point is as to their focus. Five inch lenses will be found good, but for all-round work three, five and seven inch will really be required.

It is not necessary that they should be anastigmats. As a matter of fact, the old single or landscape lenses are quite good enough for the purpose. Someone may raise the question of distortion of marginal lines, which is always given by these lenses. But we do not use the extreme fields of the



MOONLIGHT ON JAMAICA BAY.

T. L. JAMES.

lenses and even if they give distortion, it should not be overlooked that all, or nearly all, Stereoscopes also give distortion of the opposite character, so that the one cures the other. Naturally one can use anastigmats, but their cost is much higher.

The separation of the lenses is an important matter and theoretically it should be equal to the interpupillary separation, which is approximately 65 millimetres ( $= 2\frac{5}{8}$  ins.). But this separation, which is correct for normal work, that is for objects at normal distances, landscapes or architectural work, is incorrect for near objects, therefore the separation of the lenses should be adjustable.

This is most important as some of the most striking stereoscopic results are those of small objects taken quite close, for instance, the feathery head of the dandelion makes a most charming picture.

If the lenses are adjustable it is quite easy to decrease the separation to the required extent by examining the focussing screen and noting when the images of the object are centrally placed on the two halves of the plate. There is, however, a very simple rule: when an object is reduced  $x$  times the separation of the lenses must be  $1/x$  plus 1 times. Let us suppose that we are taking a near object one fourth of its natural size, then the separation of the lenses must be reduced  $1/4$  plus 1  $= 1/5$  and assuming that we take 65 millimetres as the normal separation then the correct separation will be  $65 - 13 = 52$  millimetres.

For very distant objects the separation must on the other hand be increased to three or even four inches, but the relief will not be natural.

This raises the whole question of the composition of the picture and it may be taken as an axiom that there should always be an object about six or at the most ten feet from the camera. In ordinary monocular work such an object would be, as a rule, too obtrusive and take on a distorted perspective; but in stereoscopy it merely serves to throw further planes back and enhances relief and the perspective is not exaggerated.

It may also be taken as another axiom that objects beyond 45 or 60 feet will practically show no relief. The latter dis-



VACATION DAYS.

Rupert Bridge.

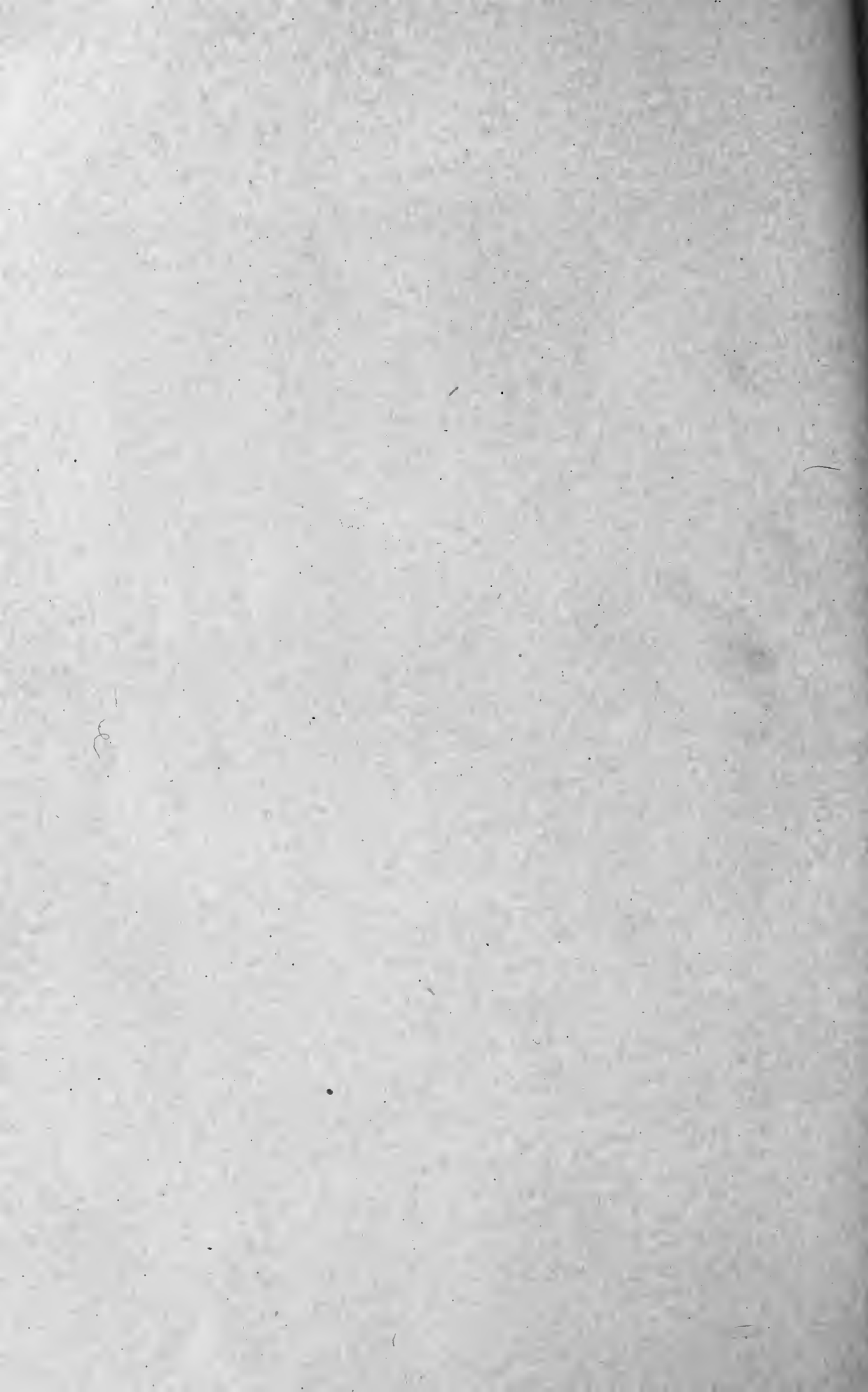



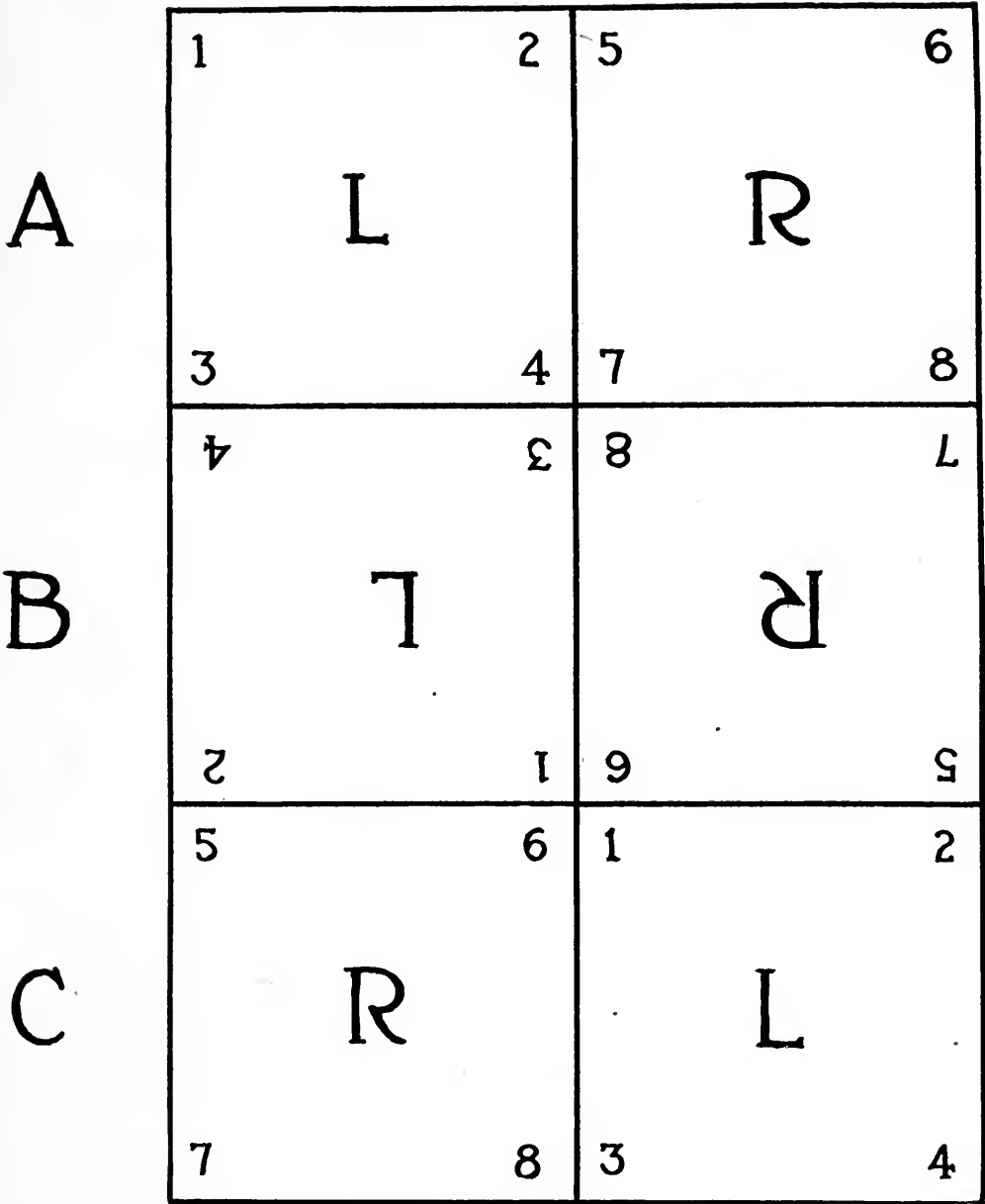

Figure 1.

*Illustrating article "Stereoscopic Photography," by E. J. Wall, F.R.P.S.*

tance varies with each observer, but the above may be accepted as an average.

Naturally any plate or film may be used and any developer. The one point to be observed is that the negative should be fully exposed and should show no extreme contrasts. Really a flat somewhat thin negative will give the best results.

Another important point is that the negative should be sharp everywhere. Fuzzy, soft or out-of-focus effects are not pleasing, in fact they are very irritating.

In making the prints there are one or two points that should be kept in mind. In the first place the prints must be fully

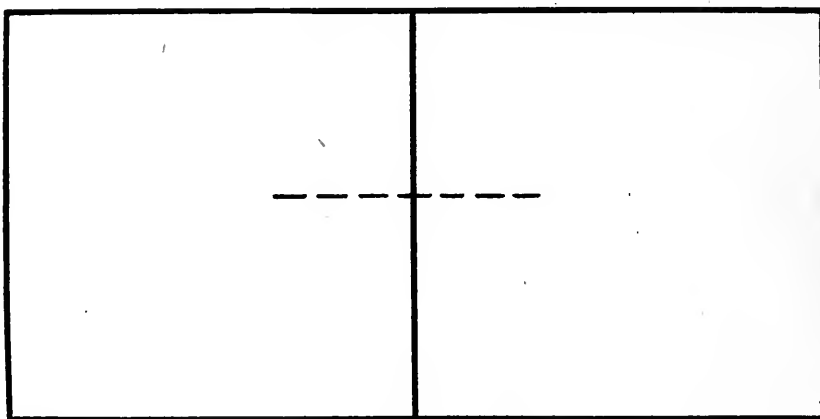

Figure 2.

exposed and somewhat flat and much too dark when examined without the stereoscope. If of normal character, in nine cases out of ten the picture in the scope will appear as though everything was covered with snow. Soft working, so-called "professional" papers are best, and above all things one must eschew any fancy surface. The "velvet" or "studio" surfaces are the most satisfactory.

It is important that the prints be properly trimmed, spaced, and put in their right positions, for the left eye must see the picture taken by the lefthand lens and the right eye that taken by the righthand lens. If this position be reversed then the result is not stereoscopic relief, but pseudoscopic, that is to say, distant objects appear in front of near ones.



JAPANESE RIVER SCENE.

THE TENKYAKWAI.

It is very easy to grasp the need of reversion if Figure 1 is carefully studied. Let A represent the object, B will then be the negative of the same and C the print. Obviously the left eye print would in this condition be seen by the right eye, which is wrong.

To set this right is very easy when you know how, but it is very easy to make a muddle of it. Place the print face down on the table, with the top away from you and across the dividing line draw a light pencil line as shown in Figure 2. Now cut down the dividing line and turn the prints over so that the pencil lines come on the outside of the prints, and it will at once be seen that the prints are in their right positions:

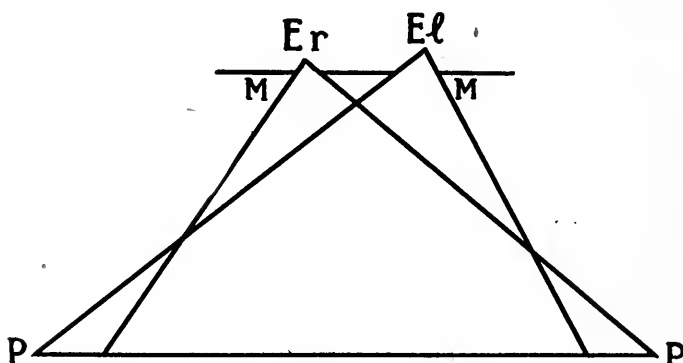

Figure 3.

There are many rules and plans for trimming the prints, but one of the most effective is the following which gives the effect, if a dark mount be used, of seeing the picture through a frame. We must first of all decide as to the size of the picture and this should not be more than  $2\frac{1}{2}$  ins. wide and  $3\frac{1}{2}$  ins. in height, and there should be one-eighth of an inch separation between them.

To obtain the framed effect the prints should be trimmed so that there is one-eighth of an inch more subject shown on the left-hand side of the left-eye print than that of the right-eye print, and there should be the same amount more on the right side of the right-hand print than on that of the left-eye print.



WATCHING FOR DADDY.

O. C. CONKLING.

The reason for this is very easily grasped from Figure 3. Let PP represent the print and MM the lenses in the stereoscope, and El the left eye and Er the right eye. It will at once be seen why the right eye sees more on the left of the print and the left eye sees more on the right of the picture. If you do not believe this, put a cup on the table in front of you and keeping the head fixed, look at the inside of it alternately with the left and right eye.



GILL & SON.

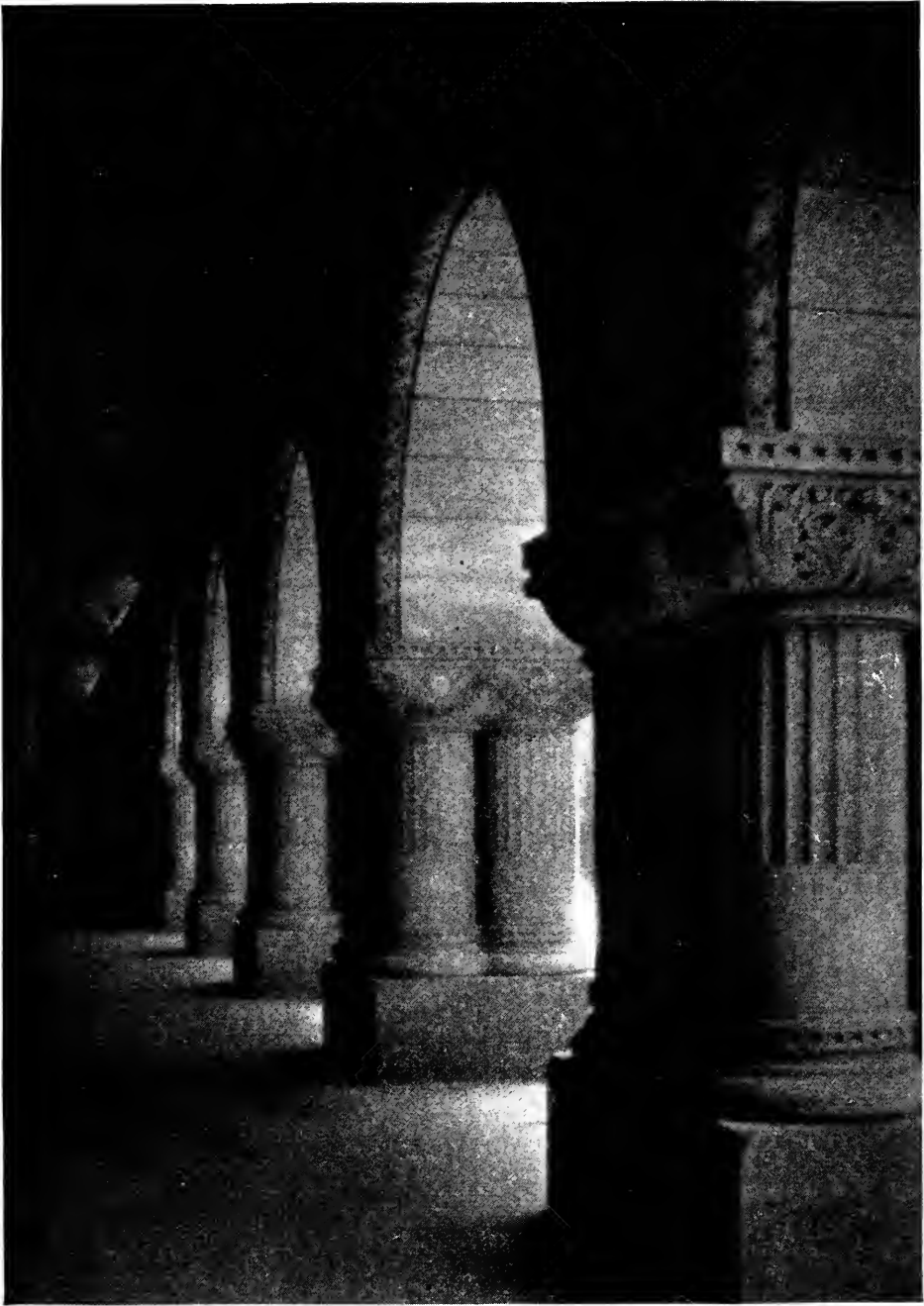

ENTRANCE TO FEDERAL BUILDING.

AUG. G. KOEHLER.



STILL WATERS.

EDWARD J. DAVISON.

## AMIDOL DEVELOPER

By EDWARD J. DAVISON



SOME fifteen years ago I used exclusively Amidol on my bromide enlargements getting blacks and whites nearer resembling iron-oxalate than with any other developer; but owing to the lack of keeping qualities after mixing I turned to metol-hydro.

About two years ago I came into possession of a formula for an acid stock solution to which is added amidol and water, and which will keep in that solution for two or three days. This has so simplified the developing that I have used nothing else for over a year.



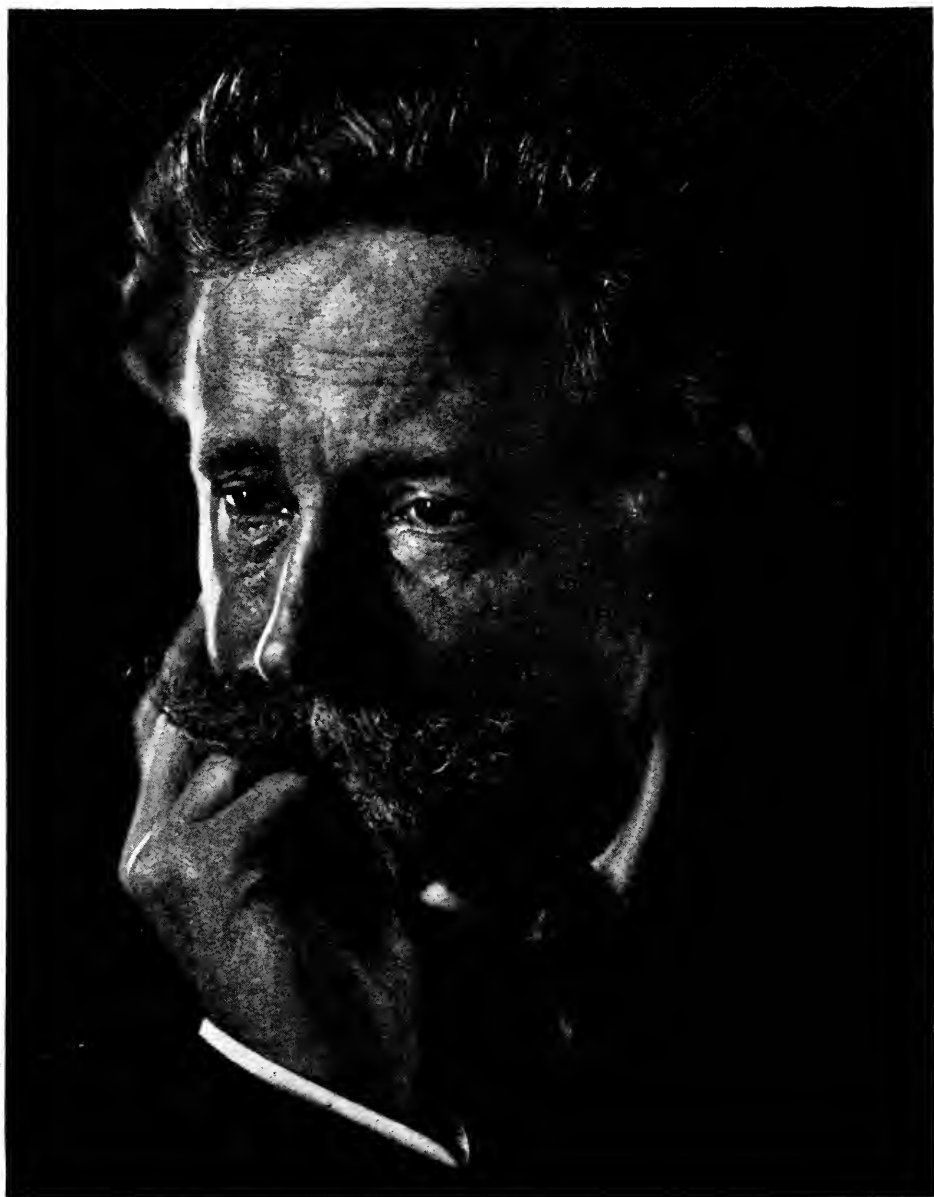

PORTRAIT.

HELMAR LERSKI.

I also find this an excellent developer for lantern slides, and where a plate is inclined to show fog I find it keeps the plate clear. It is a slow working developer, the proper time for good snappy prints being about one and a half to two minutes. For sepias it is excellent.

Here is the formula.

Stock.	
Water .....	40 oz.
Dry Sulphite .....	6 oz.
Citric Acid .....	120 gr.
Iron Sulphite .....	1 oz.
Bromide Potash .....	4 drachms

For use.	
Water .....	10 oz.
Stock .....	2½ oz.
Amidol .....	30 grains

The developer does not deteriorate very rapidly, hence will go as far as metol-quinol.



THE KITTEN'S PARTY.

SIDNEY V. WEBB.

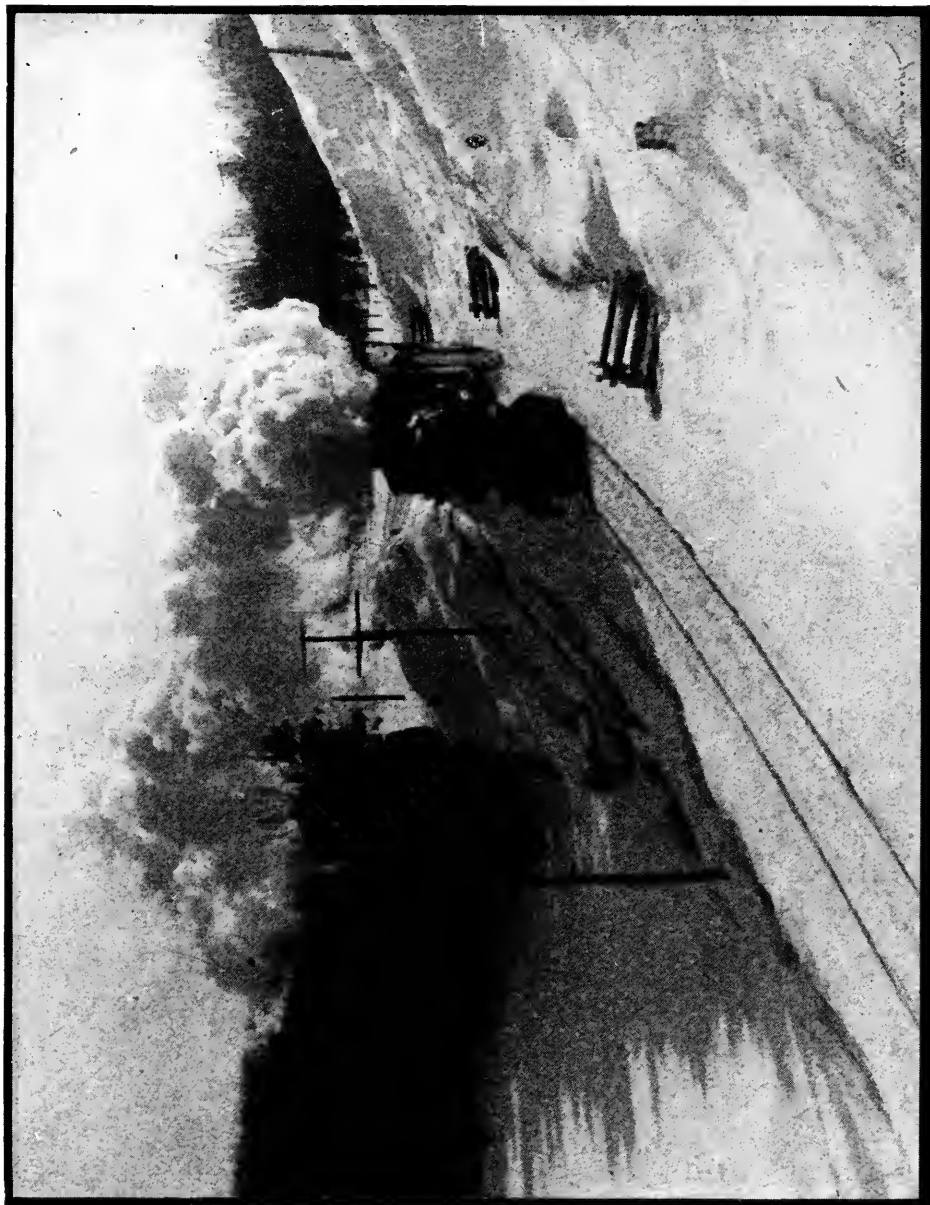

ROUNDING THE CURVE.

G. P. KIMBERLY.

## OIL AND BROMOIL FOR PORTRAITURE

By PAUL L. ANDERSON



At the present time when platinum paper is so expensive and so difficult to obtain many photographers are endeavoring to substitute some other medium for high grade portrait work, and are using such processes as carbon, gum, and oil. Among these oil and bromoil deserve attention, since very desirable results may be secured with these printing methods, and though they are not well adapted to general professional work they may be employed to advantage by advanced amateurs, who rarely wish to make more than two or three prints from a negative, and are willing to give time and effort to the production of the best possible results.

It is commonly supposed that oil is of value only for large prints, 8x10 or larger, owing to the coarse texture which is thought to be inseparable from the oil process, but this is by no means the case, the texture of the print being very largely under the worker's control. As an illustration of this, one of the writer's pupils recently made an oil print from a 5x7 full length portrait negative, in which the sitter's head was hardly more than half an inch high, which was perfectly satisfactory as a portrait, and it is the purpose of this article to indicate some manipulations by which such an effect is to be secured.

Much depends on the character of the negative to be used, and it may be said that a negative which depends for its effect on delicate gradations will not print so satisfactorily in oil as in platinum, whether the print be in a high or in a low key. The best kind of negative is a brilliant one, but this does not mean, as the term is generally used, one having strong contrasts, for only moderate strength is necessary, though the contrast of the print is entirely under control. Still, it will be easier to work with a moderately strong negative, and brilliance should be rather a question of so arranging the lighting of the subject that a rapid interchange of light and dark



THE FELDMAN STUDIO.

is obtained. If a negative of this sort is employed it will not be difficult to produce a satisfactory portrait in oil. It will be seen from this that the process is better adapted for portraits of men and women of strong character than for children, though even for such sitters it may well be used if the prints are 8x10 or 11x14.

There are on the market various papers suitable for oil printing, among them being those manufactured by the Autotype Company, and these are highly to be commended, but the writer feels that the most desirable oil paper is made by fixing Royal bromide in a plain hypo bath without exposure to light, washing, and drying, after which it may be sensitized and printed in the usual manner. This paper seems to have a thicker coating of gelatine than the regular oil papers, and in consequence it will render a stronger negative. It will, however, require the use of warmer water for soaking, since the gelatine is harder than that of the papers made especially for this purpose. The color of the Royal bromide is particularly desirable for portrait work, and if a warm brown ink is used the effect can hardly fail to be good.

It would be difficult to find a better sensitizer than the carbon sensitizer recommended by Henry W. Bennett, but a spirit sensitizer is often desirable, since this makes possible more rapid work. A bath-sensitized paper will require two or three hours to dry, depending on the atmospheric conditions, whereas one sensitized with a spirit sensitizer will dry in from five minutes to half an hour. The Autotype sensitizer is very good for this purpose, but more convenient—because more flexible—is one made up from a saturated solution of sodium bichromate in conjunction with alcohol. The stock solution is

Water .....	4 ounces
Sodium bichromate .....	1920 grains
For use take	
Stock .....	1 to 8 drams
Alcohol 95% .....	up to 2 ounces

This is applied to the paper by means of a Blanchard or flat Japanese brush, and if a constant quantity is used for a given size of sheet the results will be constant. The stronger mix-



THE PICTURE BOOK.

ARTHUR DARING.

ture is to give soft prints from strong negatives, and vice versa.

It will be well to obtain, if possible, the imported brushes, but if this cannot be done the "fitch stipplers, cut slanting," to be got from a dealer in painters' supplies, will be found quite as satisfactory though not so durable, and are much cheaper. It is advisable to clean the brushes with gasoline immediately after use, and to keep them in cones of stiff paper, that they may keep their shape.

Much cheaper than the imported inks, and quite as good, are the stiff litho inks to be obtained from a dealer in printers' inks. These may be got in quarter pound tubes, and it will be found that black and burnt umber are about all that will be needed for portraiture, a very pleasing brown being made by mixing them in approximately the proportion of one part of black to two of burnt umber.

The contrast of the print depends on the quality of the negative, the strength of the sensitizer, the degree of soaking, and the stiffness of the ink, a thin ink tending to give flatness. Experience alone can teach the proper treatment of the print, but it may be remarked that it is well to use the stiffest ink possible, for the reason which will be indicated in the next paragraph.

It has been said that the texture of the print is largely under control of the worker, but it is not possible to get as fine a texture as platinum will give. It is obvious that the image is built up by repeated applications of ink, each hair of the brush leaving a little spot of ink as it touches the paper. If a thin ink is used a relatively large quantity will adhere to the paper with each touch, whereas if the ink is stiff a less amount sticks to the paper, and it is necessary to give several touches in order to get the desired depth of shadow. Since the hairs do not fall in the same place each time, it will be apparent that the texture will be less grainy with a stiff ink than with a thin one, and this indicates the method to be followed in order to secure the finest texture. Of course, it may not be desirable to apply much ink to a given space, and in that case the texture may be rendered fine by working over and over a given area without taking up more ink on the brush. The texture must necessarily be finer in the case of a small print than with a





AT EVENTIDE.

Harry D. Williar.

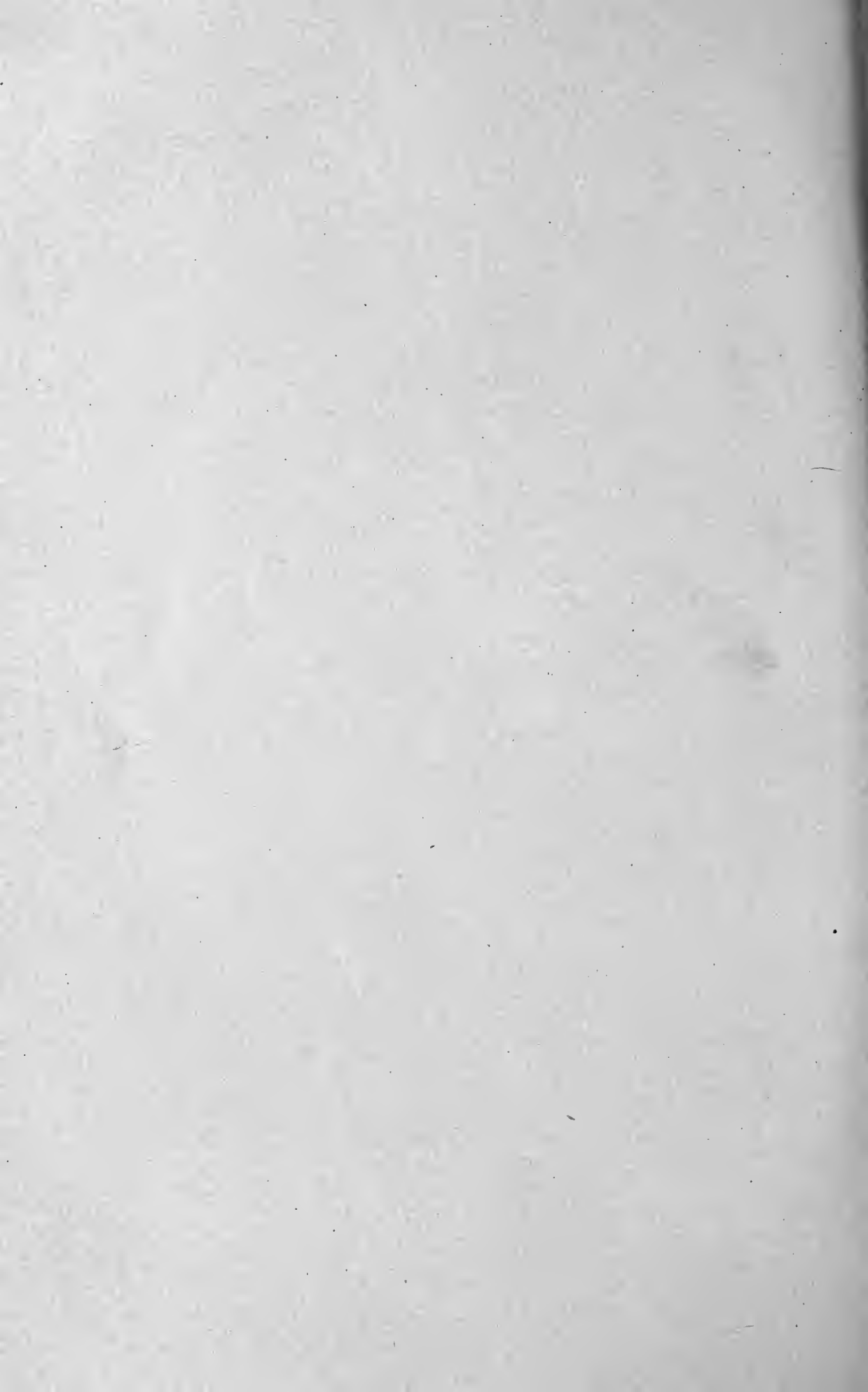

large one, since the viewing distance is less, and the worker should move away from the print from time to time, in order to see it as it will be seen when finished. It is a waste of time and effort to make the texture finer than the viewing distance demands.

As regards the time required to make an oil print, the inking will demand perhaps half an hour in the case of an experienced worker, and this holds true of large as well as of small prints, for the large print does not need so much working over as the smaller one. The sensitizing, printing, washing and soaking may be done very rapidly, especially since the paper prints much more rapidly than any other daylight printing medium, even than platinum. In general, a dozen prints might be considered a fair day's work, and it will be seen that in this respect oil cannot compare with platinum, for a good worker in the latter medium will make three or four hundred prints in a day. Therefore it will be necessary to charge a much higher price for oil prints if they are made commercially, and in most cases it will not be possible to secure an adequate amount, though there are some workers who use oil exclusively for portraiture. The only advantage of bromoil over oil lies in the fact that it is possible to make large prints from small negatives in the former medium, whereas oil requires a negative the same size as the print. As against this, bromoil offers all the possibilities of failure inherent in oil, with the addition of a few which are due to the more complicated nature of the chemical reactions. The writer, in general, prefers to make a large negative and an oil print unless but one print is desired, in which case bromoil may be simpler.

It is therefore recommended that those workers who are accustomed to employ platinum turn their attention to oil, and the writer feels confident that anyone who will give the time and effort necessary to become familiar with the process cannot fail to be enthusiastic over the results obtained.



QUEENSBOROUGH BRIDGE.

HASWELL C. JEFFERY.

## A PLEA FOR PINHOLE PHOTOGRAPHY

By J. E. ADNAMS.



WHY should I use a pinhole when I can afford a lens? The question is a reasonable one. It is as if one said, "Why should I go for a walk when I have the chance of riding in a motor?" Certainly if it is a question of getting there with the least trouble and in the shortest time, the vote must be in favor of the motor and the lens.

But there are times when a walk is preferable to a ride, and there are occasions when it is advisable to use a pinhole in order to produce a certain effect.

Pinhole photography is too often looked upon as a mere scientific curiosity, interesting as an experiment only. It is more than that and I hope to induce some of the readers of the Annual, who have tried all the other photographic processes and have begun to feel like Alexander the Great that there are no more worlds to conquer, to give a trial to pinhole work, not as a curiosity but as a new accessory in their pictorial work, when I think the result will come to them as a revelation.

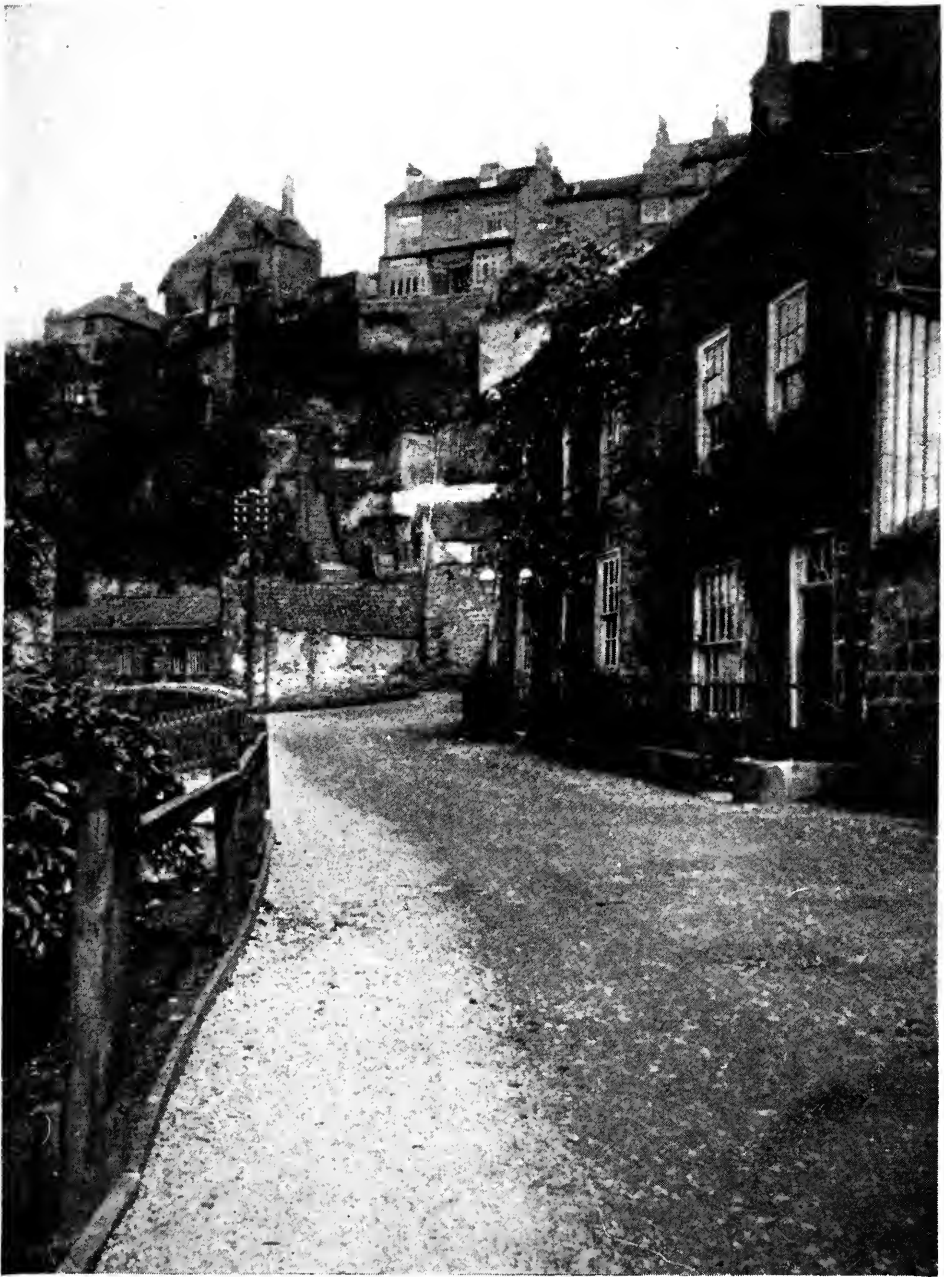

A BIT OF OLD KNARESBORO.

*Illustrating article "A Plea for Pinhole Photography," by J. E. Adnams.*

I do not suggest that they should scrap their lenses and substitute pinholes, but use the pinhole for special purposes suited to it. The pinhole has its limitations, granted, but there is a special beauty and charm about the image produced by it that is very delightful. True it is never dead sharp, but to say it is fuzzy is a great mistake.

It gives all the detail, but softened and subdued, no one plane is sharper than another, its infinite depth of field foreground and distance are equally defined, and yet the effect of distance is particularly well rendered.

There being no focus the definition is the same whatever the distance between the pinhole and the plate.

This makes it very adaptable for use as a wide angle or narrow angle instrument. If placed near the plate it gives a wide angled picture and vice versa.

The human eye sees everything in focus as it wanders over a scene, but with a lens if foreground and distance are wanted in focus at the same time it is necessary to stop down considerably and that gives rise to a hardness and sharpness that few people think artistic.

Much ingenuity and time have been expended by makers to produce "soft focus" lenses which will get over this, but such lenses are expensive, and the same soft effect can be obtained with the pinhole without any trouble or expense.

One property of pinhole work which is sometimes of great assistance in architectural work is its treatment of moving figures. Instead of representing them as a blur it simply leaves them out.

The addition of a pinhole to one's outfit is a very inexpensive matter. If it is applied to a folding stand camera advantage may be taken of the power to regulate the size of the picture by the distance from the plate as mentioned above, but if no suitable camera is available it is a simple matter to make a light tight box to act as a camera, and the pinhole costs no more than the trouble of making it, and that is very little.

Any subject which will bear a time exposure will be suitable for pinhole photography, and it is particularly well adapted to still life, flowers, copying engravings, drawings, etc., because there is no need for focusing. It also does away with



SAND DUNES.

J. K. PETERSON.

the necessity for a very long extension of the camera when copying the same size.

Apart from the usefulness of the pinhole, it will be found to be very interesting to make the trials and experiments necessary to acquire familiarity with it, and will turn out to be well worth all the trouble.



FALL.

P. J. SCHWEICKART.



## GALLERY LIGHTING

By SIGISMUND BLUMANN



IN every line of endeavor the professional is inclined, and not altogether without cause, to hold the amateur in a species of contempt. In the arts the workers for profit offer a sort of indulgence to the dilettante which is contempt refined, but contempt none the less. There is reason in this. Let us examine the cause. At the bottom lies interference with income. That is a serious matter. Men who do things for fun are dangerous in increasing degree as to their ability. The better the work done for nothing the greater loss to him who works for a living. Artists are notoriously improvident but they are not foolish. They realize their commercial enemies. More spiritual is the hatred of men who devote their lives to serious efforts at fine production for such as fritter away time and material and corrupt popular taste with mediocre and aimless activity. The amateur or dilettante is so ubiquitous and so very numerous, too.

But there is a reverse side to every coin and an opposite argument to every question. Art and the artist owe much to a contingent who without hope of gain and for unalloyed love of the labor give the best in them and are not aimless or mediocre. They have other means of livelihood and so can afford to resist the temptations to pot-boil which assail those who live by their art. To the superior amateur ideals come first. He does not compete but he is a pacemaker and not infrequently he is not loved by the professional whom he gears up.

What the Gallery Photographer, to get down to our subject, overlooks is the debt he owes the non-business pictorial portraitist. It must be conceded that the amateur has freed us of the three-quarter lighting, and the conventional poses. Who will say that backgrounds, but for his radicalism, might not still be palpable canvass arbors, "practical" or more truth-

fully very impractical windows, stage furniture, and stucco rail and pillars? What courage was required to brave public opinion with rough paper and unconventional mounting might never have been possible to those whose bread and butter depended upon doing just what was known to sell? True, in times almost remote, some artist with commercial acumen brought a training with the brush to bear while conforming to his times and glimpsed the future in his work. Sarony had all the paraphernalia, from vine covered trellis and ornate chair to neck clamp, but occasionally he dared to experiment with plain backgrounds and threw the light full on his subject. Let the reader look over the back files of any of the old photographic magazines and he will see that the prize winners of twenty-five years ago have a very professional look, which seems to have taken the form of almost absolute uniformity. And noting those prints which win prizes in our time, it will be seen how amateurish in everything but excellence these are.

We not only tolerate greatly diffused backgrounds and everyday poses, but we pay exceptional prices to the camerist who can get us just as we are in our ordinary clothes, ordinary surroundings, and ordinary moods. To do this a skylight is less a necessity than a convenience. With lights running from the floor to half over the ceiling the shades are manipulated to simulate that effect which a window in our home would give. We are permitted to be in profile, if we be sensitive about that wart on the other side, or to full face the lens. Why, we even are permitted to keep on our eyeglasses. And if we prefer to sit we are given the kind of chairs that exist in the world at large. Furniture is real furniture, windows are real windows and the portraits are real portraits of real people. If the picture be charming it is because the ability of the artist has succeeded in finding the charm that is in us and has accented not forged it.

Is this to be dismissed as a tendency of the times? As mere evolution coming spontaneously? Not at all. Popular education made it possible. And the Kodak made popular education. I am not in the employ of Mr. Kodak Eastman. But at the risk of being offered a job on his advertising staff and becoming one of Mr. Jones's assistants, I will say that every million dollars a year spent in advertising the Kodak has made



CHILD PORTRAIT.

Ira D. Schwartz.

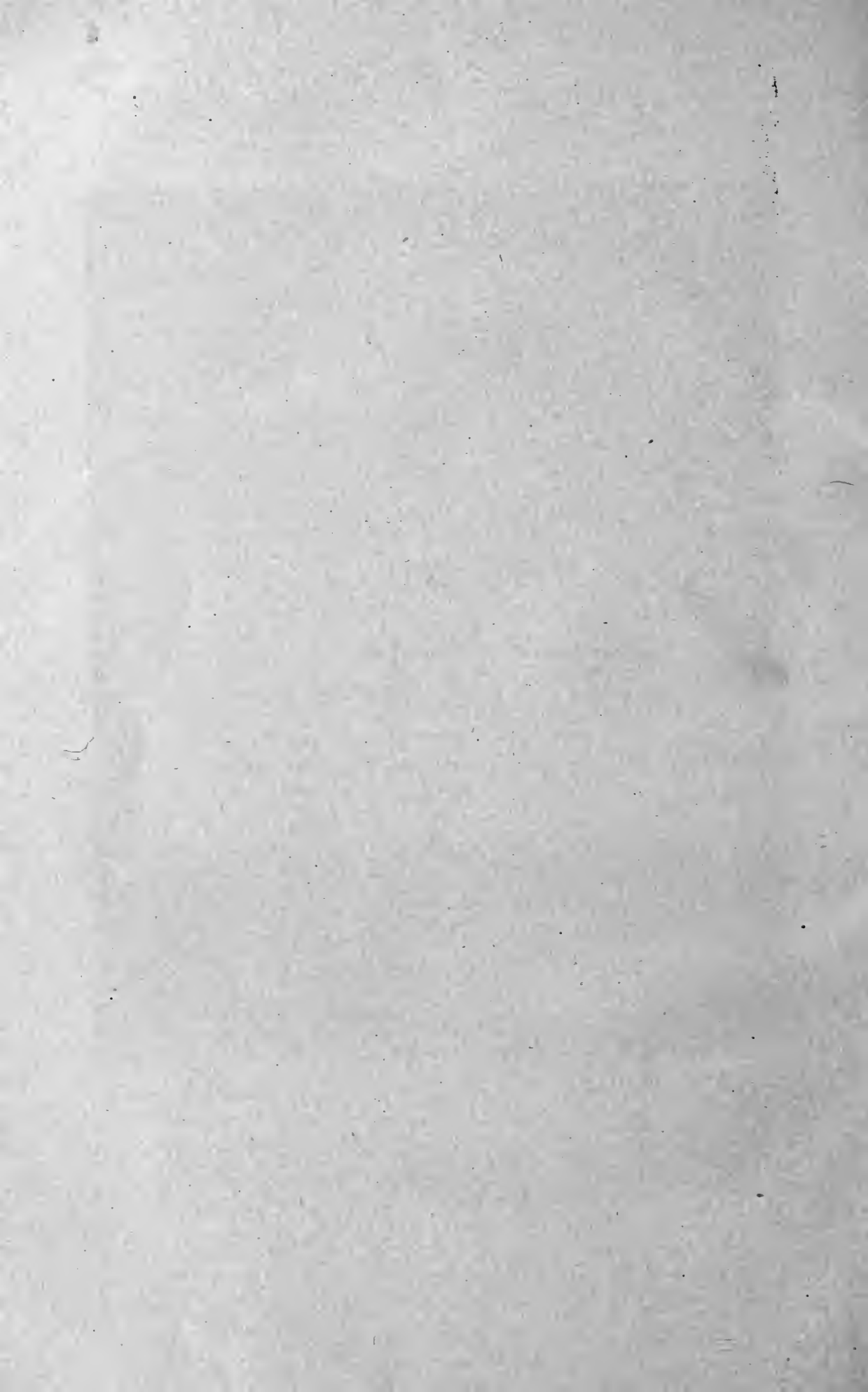

a million amateurs a year. That at a low estimate one percent of these amateurs become adepts. That another twenty percent become appreciative of art and artistic standards which otherwise had been unknown and unthought of to them. That hundreds of thousands of these are the best patrons of the high class professional photographers. And that the whole course, the upward course of portraiture may be traced to the first slogan "You press the button: We do the rest."

Such work as Garo, Goldensky, Strauss, Pierce, and others do, and such mounts as they give their prints was first introduced by the amateur and then bought by him.

It may be questioned as to why this rambling talk has been called Gallery Lighting. Well, I'll tell you. A stiff cardboard, probably of glossy black or dark brown, with the name of the Studio in the lower right corner, a carte de viste, cabinet, or Paris Panel size print thoroughly glued on and not unlikely highly glazed with a high embossing to add effect, a face turned a little from the front, light three quarter top and front, an elaborately carved chair with plush upholstery and fringe and tassels, a marble topped table on which to lean the elbow, a carefully crooked arm and drooping hand, a spotted alabaster retouched complexion, One Fifty for the smallest size, Cabinets Three Dollars and a half please, and this very fine large Panel Five Dollars. All this, dear reader, is to use a comprehensive term "Gallery Lighting."

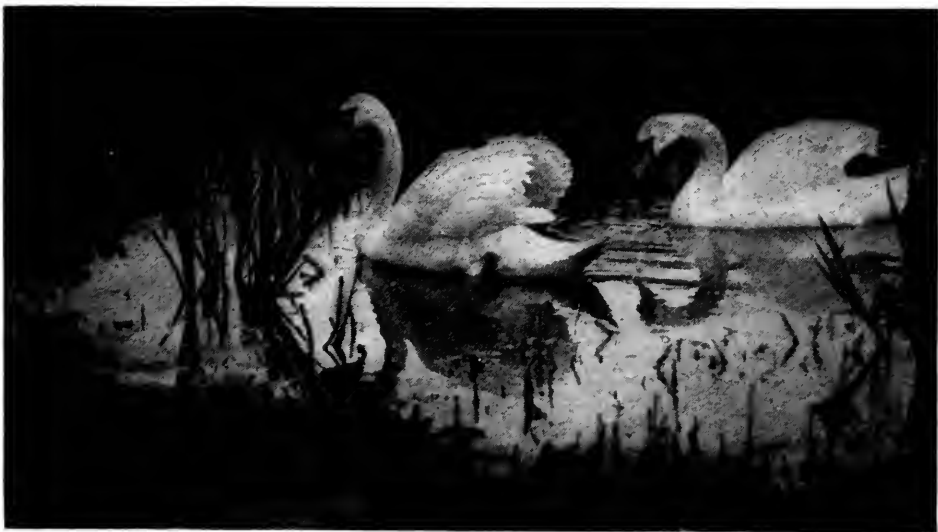

SWANS.

THOMAS CARLYLE.

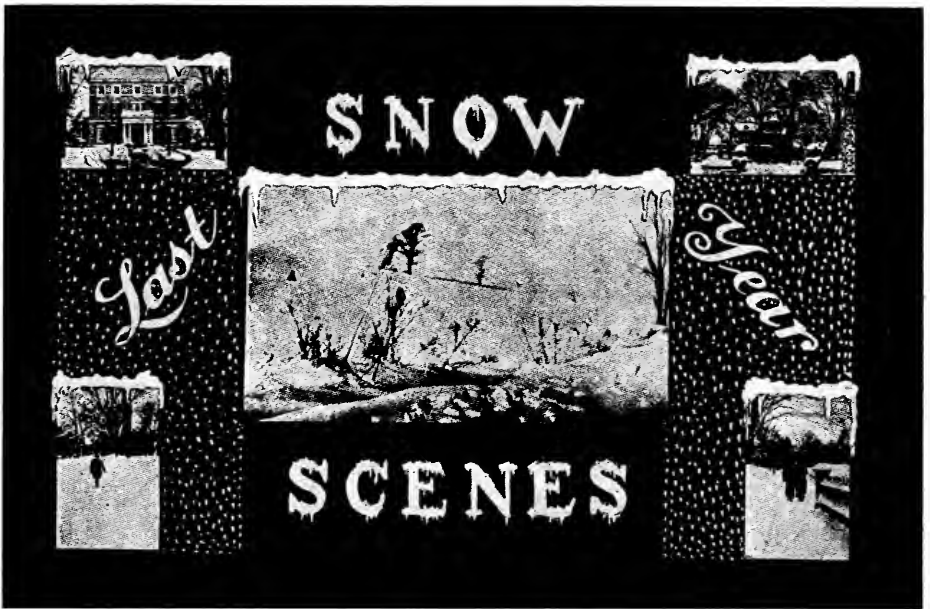

Figure 1.

*Illustrating article "Border Frames for Photographs," by W. J. Curzon.*

## BORDER FRAMES FOR PHOTOGRAPHS

By W. J. CURZON

**P**ICTURE dealers know the value of an appropriate frame about a picture. It is really an art to select a frame which will bring out the beauties of a photograph rather than detract from the subject.

We hear so often the expression, "something plain and simple." There are many people who think that the plainer and the simpler the frame the more effectively the beauties of the composition will be accentuated. On the other hand, there are those of us who believe that a little style, smartness or "pep" in a frame is not objectionable.

So much progress has been made in the art of photography in the last twenty-five years that it is indeed difficult to call a

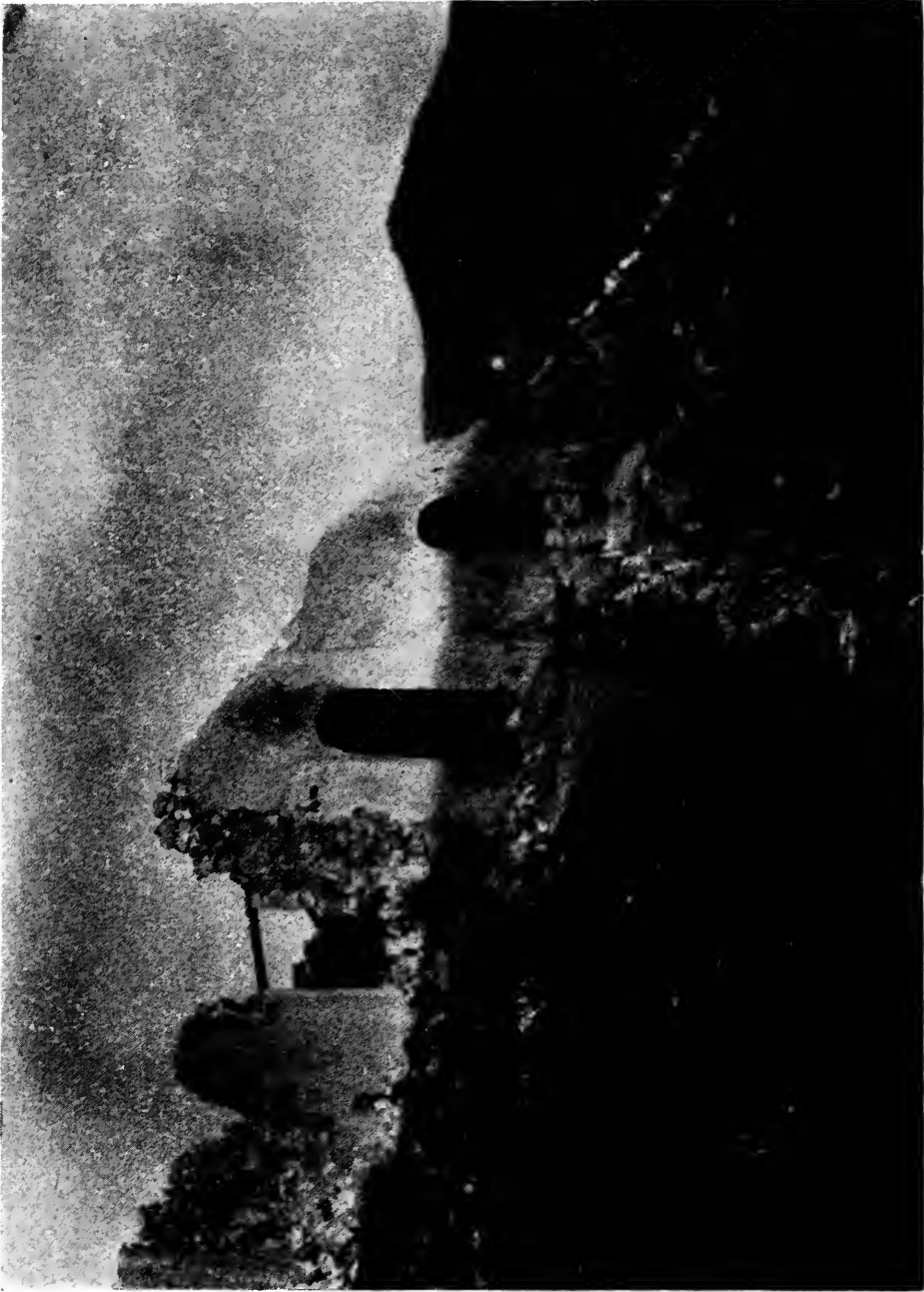

JAPANESE RUINS.

THE TENKYAKWAI.

reader's attention to anything which is entirely new. The old adage, "Nothing new under the sun" will apply, but the fact of the matter is that although the ornamenting of the photographs as prints on cards or mounted in albums is not entirely new, many very effective borders have recently been designed which are easily accessible to all amateur and professional photographers for the elaboration and the beautifying of their prints, whether mounted on cards or in the pages of photographic albums.

The discovery of *Johnston's Snow White Fluid* which is



Figure 2.

equally serviceable with pens, brushes or air brushes has made it possible for amateurs, as well as professionals, to elaborate and to dignify their work.

The illustrations, Figures 1, 2 and 3 will suggest designs which any amateur photographer might easily make with a little care, yet which unquestionably increase the interest of the prints, whether they be mounted separately or in a series.

Professional photographers will be particularly interested in this new preparation not only for border line work, but for the



writing of names or signatures. It flows as readily from a pen as a black ink.

As an *opaque* this new discovery is of special interest to photographers since it enables the worker to see readily where the retouching has been done on the emulsion of a plate or film. For tabulation purposes white fluid has a tremendous advantage over black ink which is self-evident.

Any desired tint may be secured by simply mixing with dry pigment coloring "melted in a drop of wood alcohol," or by mixing the coloring directly into the white base.



Figure 3.

Another advantage—or rather blessing—in connection with this new material "Made in U. S. A." is that the fluid is always good. The simple addition of a few drops of water and a little stirring will put the material in working condition at any time it is to be utilized in the years to come.

The illustrations accompanying this article are simply given as suggestions. There are hundreds of different ways in which these borders may be arranged according to the individual taste of the photographer, be he professional or amateur.

## BABY'S BEST BIOGRAPHER

By ROY HARRISON DANFORTH



HEN Owen Wister wrote "The Virginian" and included the episode of the mixed babies he convinced everybody of its verisimilitude except the mothers of America. No mother would admit, under any circumstances, she would fail to recognize her own child. If one hundred mothers were shown only the tips of the toes of their respective babies from beneath a curtain, ninety-eight of them certainly and calmly would go up to the curtain and draw forth their own. Display an ear or an eye and a similar percentage of fathers would accomplish the feat. Never was a better testimonial to the value of careful observation. Never was observation more careful and constant than that of babies by papas and mammas. It extends with almost equal diligence to the contemplation of babies' portraits and with equal persistent refusal to observe anything therein but the creditable. So the professional photographer of babies, with even mediocre skill, finds constant appreciation of his work, and not less so the amateur photographer of babies with almost no skill at all.

But this is a period of better baby pictures as well as better babies, chiefly because more of them are taken. The days of the modern infant are filled with eating, sleeping and picture-taking. The baby book, in which appear his pictures from the time the nurse lifted him before a window while daddy snapped the shutter to the day when he rebelled against further ignominies of the kind that posing entails, lies upon every family drawing-room table.

Now, there is no particular reason why these books should not present pages of general interest as well as interest solely to the parties of the first part. There are many general reasons; for instance, the perversity of photographic apparatus, the lack of adult intelligence in the subjects, and the failure of parents to have specialized in psychology in their college



STUDY.

M. S. WARFIELD.

courses. For baby photography is primarily psychology and only secondarily photography. Half of an article of this kind ought really to be written by the academic observer of infant minds, and only half by one who has given attention merely to the manipulation of cameras, negatives and prints; since the first problem of taking a baby's picture is to get him where you want him when you want him—and that is psychological.

Much of the difficulty could be avoided at the start if people would only remember that posed children make the poorest pictures; that is, when they are posed by someone else. Left to their own resources they can find more attitudes, more expressions and more adaptations of Hogarth's lines than one could possibly find for them. Simplicity, that sine qua non of childhood pictures, they best achieve themselves, but they are seldom assisted to it. Grace and pliancy are in their little bodies every instant until older hands assist at these bodies' posturing.

The less one does to interfere with the unconscious movements of children in gaining their objects, the more certain one is to picture them at their best. This means self-effacement. The child must be permitted to forget that camera and photographer are anywhere about. He must be permitted to become familiar with the camera, to touch it, look it over, see how it works. The more often he sees and handles it, the less attention will he pay to it. Moreover, babies cannot be kept waiting. Arrangements to take the picture must be completed before one goes about taking it. Babies and young children are constantly moving; there is no static condition with them except while they are asleep—when, by the way, some of the most attractive pictures of them may be taken. The photographer faces, therefore, the alternative of snapping them while they are in motion or attempting to catch them during a momentary pause.

Between the resulting possibilities of movement in the picture and under-exposure there can be, however, no choice. The former is to be risked every time, for if there is one kind of photographing on earth that will not give good results through under-exposure it is that of the little child. The glaring whites of the dresses, the chalky tones in the flesh and the frequent entire loss of the one side of the face that was in

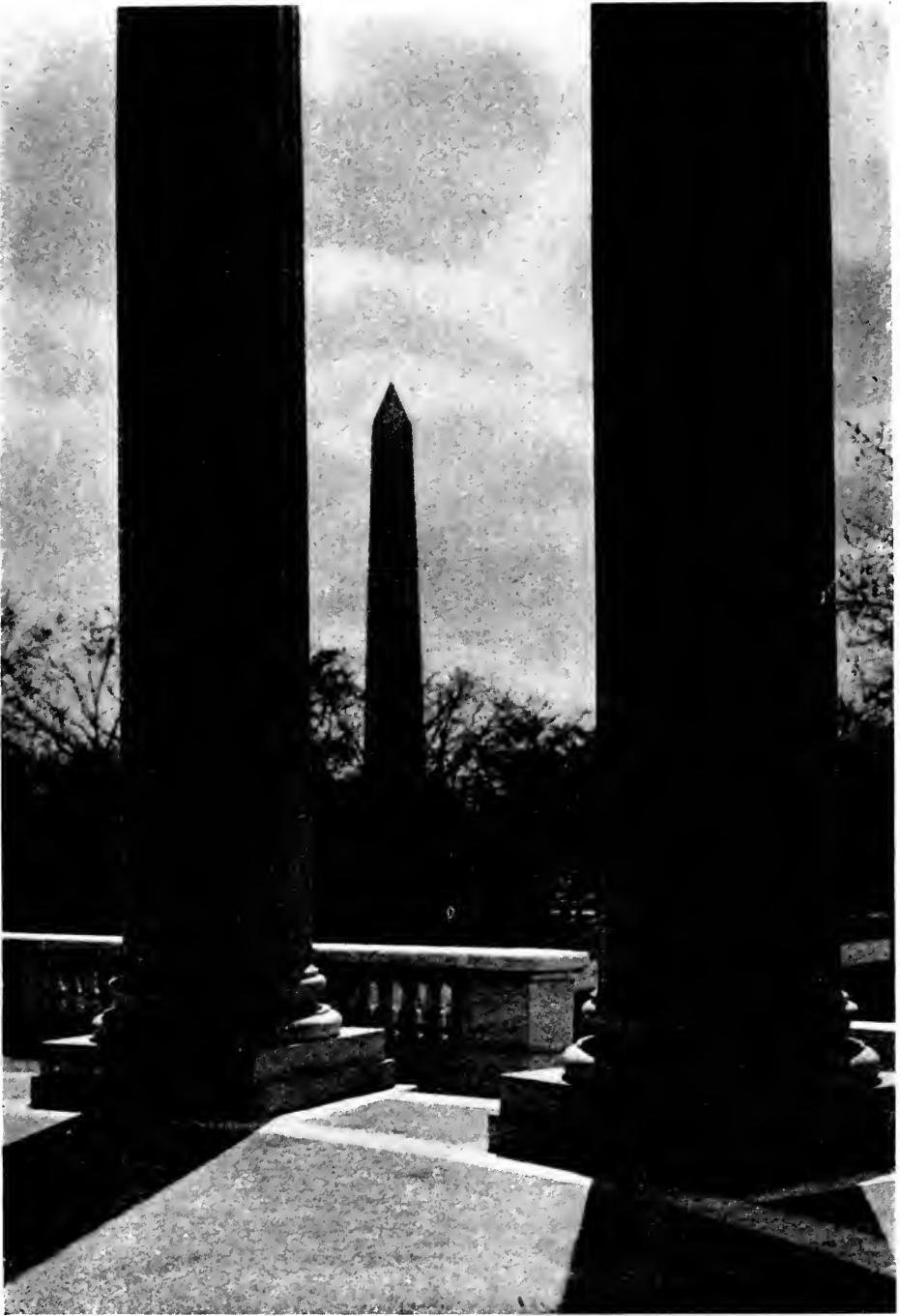

WASHINGTON MONUMENT  
FROM THE D. A. R. HALL,  
WASHINGTON, D. C.

CARL H. KATTELMANN.

shadow contribute to most of the failures in infant photography.

About getting the child where you want it when you want it, there are one or two more considerations. The young child, say up to three to four years old, not because of original sin, but because he really must keep on the move to get all the things accomplished that seem necessary to him, will not take orders when he is before a camera. Past four years old, you may be able to persuade him to do a few things for you when you ask. Again, children in groups are not always to be supposed harder to photograph than individuals. Pictured at play, in the midst of their games, no matter what these be, they will be constantly assuming more pleasing arrangements than you can keep up with, however rapidly you press the bulb. Even when not at play, they can be persuaded of the policy of helping you very often by the mere suggestion that those who do not help will probably look ugly in the picture.

Everyone will take pictures, of children or anyone else, with the best camera that he can afford, and there is no use advising any particular sort of equipment. The best is the best, in this as in other work, but there is no camera in existence that will take pictures that will not take pictures of little ones. More depends upon the camera's user than upon the instrument itself. Excepting that orthochromatic plates and films give a better rendition of the flesh tones, there is no further consideration to note with regard to equipment. Either tank or time and temperature development are best for juvenile pictures as they are best for any other.

One of the chief requisites for the making of the best pictures of children is plenty of exposure. Not only should time or a slow snap be employed whenever possible, but as large a stop as is available under the conditions should also be used. The large stop affords facility also for sufficient diffusion in the finished picture. Too much definition does not help children's pictures.

The figure of the child is so small that care must be taken ordinarily, by limiting the extent of the background and surroundings, to prevent its being lost in a multiplicity of other detail. Yet sufficient space should intervene between it and the margins to indicate its tininess. From the height of a



THE FOREST IN THE POOL.

WM. LUDLUM, JR.

man's eyes the expression of a child's face will be found to be quite different from that obtained from its same level. The tilt of the head, the angle of the eyes, and the contour of the baby face are all changed as the camera is lifted above the little head. Experience will show the differences, but they must be kept constantly in mind. As a general rule, the photographer should have his own eyes always on a level with the camera to make sure that the expression of the face is what is desired and that no distortion is apparent.

The problems of child photography are cut squarely in two by the division into indoor and outdoor picture making. Because the former is far more difficult, it may be well to consider its phases first.

If there is one golden rule of indoor child photography, one necessity without which such portraits never will be good and with which their chief difficulty is removed, it is that the key of the whole picture must be high and light. Too much emphasis cannot be placed upon this need. Observers of indoor child photographs are surprised to learn how many of the excellent pictures they see are snapshots and, more astounding still in many cases, snapshots made with lenses working no faster than F/8 or stopped down to that aperture. The explanation is the high scale of tones that are permitted to enter into the picture.

Put your child in the whitest rompers, or dress, in its wardrobe; not freshly starched clothes, for those will have ugly angular lines and shadows, but in something soft and pliable. Have plenty of hangings and other furnishings about of a similar tone that will reflect the light, and give all the light from the windows that is possible at every angle. Take care that there are no deep shadows, even on the white goods; either smooth out the folds that appear, or throw light into them from reflecting surfaces. Keep direct beams of sun off the little figure, except for special effects, diffusing the rays if necessary through thin white or pale yellow cloth. A little experiment will show that, under these conditions and with full light through ordinary windows, snapshots will not be impossible. Sometimes a tenth of a second will be necessary to give full enough time; often a twenty-fifth will be none too brief.



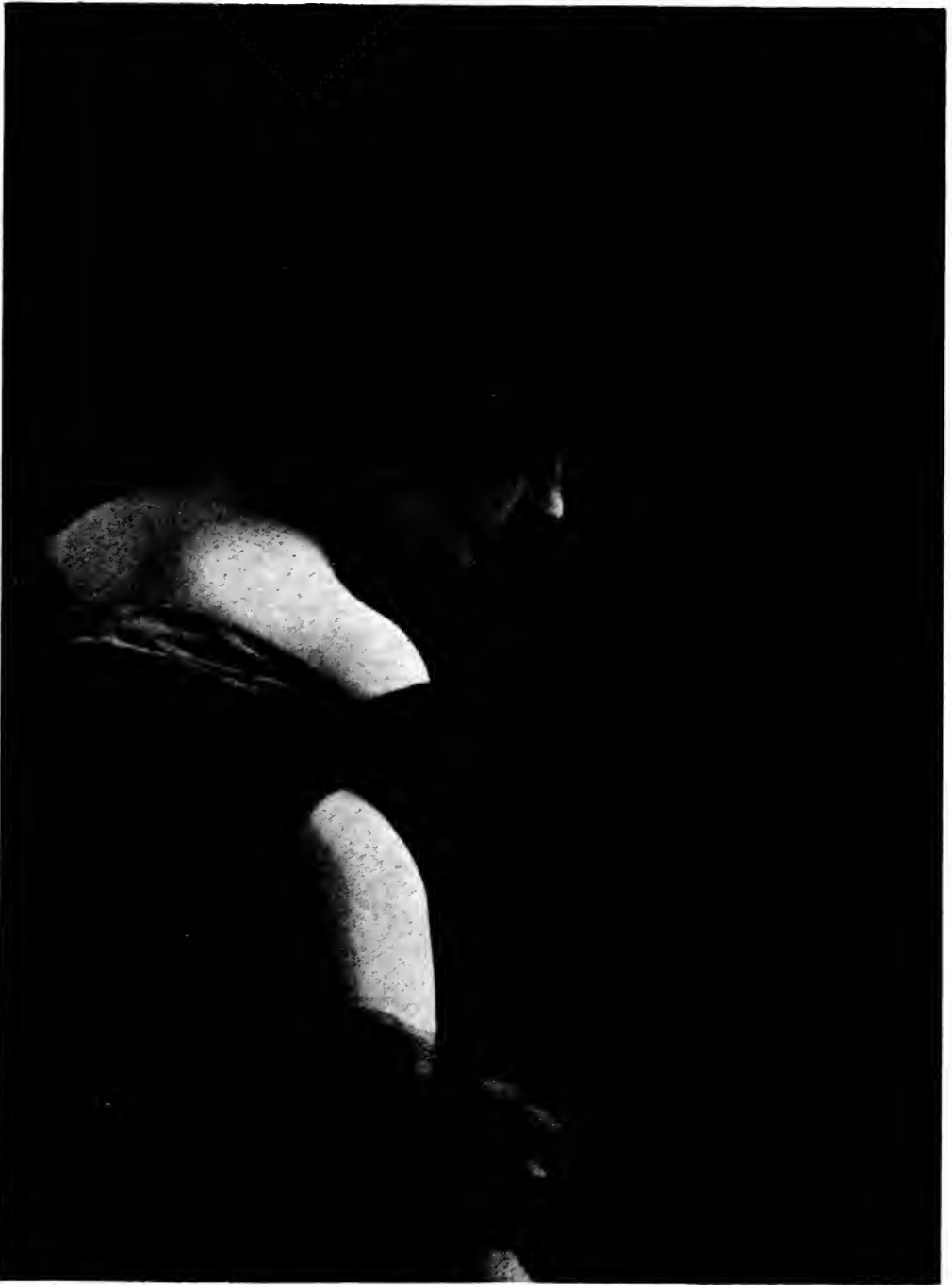

CLAUDE H. SIMSON.

One position of the camera, squarely in the window, is often of value, helping to make the exposure short, if the subject is not too far away, and furnishing a broad lighting effect. The window shade, if it is of light material, may be held out in the room above the baby's head as a reflector. Remember that the intensity of the light varies as the square of the distance from its source and keep the baby as close, therefore, to the window as possible. Sometimes an interesting effect may be achieved indoors by putting the subject squarely in the path of a beam of light as it falls through the window, when the exposure will be but slightly longer than if the baby were intercepting the same rays outdoors.

Backgrounds and surroundings indoors must, as a rule, receive even greater attention than those outside, because their artificiality comports but poorly with the naivete of the subject. The rapidly dwindling light as the back walls of an ordinary room are approached will often assist materially toward this end by throwing these walls into obscurity. If they are still unpleasantly obtrusive, soften them by focusing well within their distance. Nursery walls are almost always appropriate to children's pictures however gaudy or bizarre their designs may be. If the child is seated in a chair, or near a table or other furniture, make sure that the child's figure is not unpleasantly crossed by the lines of the furniture.

As white or light garments are best always for inside pictures, medium colored or darker garb is preferable for out-of-doors. Nor does full sunlight usually assist toward the best child photographs. If the sun is bright and the picture must be taken that day, choose a place on the shady side of a building, but where the top-light is not cut off and slightly increase the exposure. More than anywhere else, remember that in children's pictures the exposure must be for the shadows in the faces. That pretty pink sunbonnet will quite blot all expression from the little girl's eyes, and the shadow of the kite will be just as unkind to the boy's features unless this rule is kept in mind. On the beach or water or in the snow there will be a compensating reflection from beneath, but here the opposite peril of over-exposure must be kept in mind. For most out-of-door pictures of children a day when the sun is somewhat hazed and when an exposure of one-tenth of a



second to one-twenty-fifth is about correct, will be found most advantageous.

There is one sort of picture of children, which may be taken out-of-doors and which gives unusually attractive results, wherein the conditions advised for indoors are followed. This is invariably to be taken in the shade of the house or other building, but with the top lights unobstructed. The child is seated in a white chair, of as near its own size as possible, clothed in white garments and with either white shoes or no shoes at all. The background, too, must be white, and for this purpose a blanket with no creases serves best. Care must be exercised against shadows falling upon the background. A slightly prolonged exposure, soft focus and somewhat less than full development give the best results. This is, in fact, one of the few situations for which other than normal development is to be advised. In finishing the prints vignetting is sometimes desirable. The plan may hardly be tried with success with a child too young to maintain its position.

In conclusion, a restatement of the vital factors in child-picturing may not be out of place, and most important of all of these is to give full exposure. Indoors put the child in such surroundings as will give a high, light key to the finished picture. Out-of-doors prefer dull-toned clothes and shady or a hazy day to sunny situations. And, from that psychological angle again, cultivate patience and ingenuity as your very best stock in trade.



NEAR BLACK ROCK

MAURICE THOMPSON

# American Annual Formulary

In the following section we have gathered together a typical collection of Formulæ and Tables, which will assist the photographer in his every-day work. It will be noticed that makers' formulæ are omitted. These can best be obtained by direct application to the makers. The appended formulæ are selected from the working methods of practical photographers.—Editor.

## TRAY DEVELOPERS FOR PLATES AND PAPERS

*Adurol—For Plates.* No. 1.—Water, 10 ounces; sulphite of soda,  $1\frac{3}{4}$  ounces; adurol, 85 grains.

No. 2.—Water, 10 ounces; potassium carbonate,  $1\frac{1}{4}$  grains. For average outdoor exposures use equal quantities Nos. 1 and 2; for fully timed exposures take 1 ounce each of No. 1, No. 2 and water.

*Amidol.* A concentrated developer for plates.—Water, 13 ounces; sulphite of soda (crystals),  $2\frac{1}{2}$  ounces; when dissolved add amidol,  $\frac{1}{4}$  ounce. The solution keeps fairly well in bottles completely full and well corked. For use take 1 ounce of the concentrated solution and dilute with 3 or 4 ounces of water.

*Amidol.* For gaslight papers.—An excellent developer for those subject to metol poisoning. (V. Serin.) Amidol, 60 grains; sulphite of soda crystals, 650 grains; potassium bromide, 10 grains; water, 20 ounces. Will keep only three or four days. Time of development about  $\frac{1}{2}$  minute.

*Duratol-Hydroquinone—Universal Developer (M. D. Miller).*—Hot water, 16 to 32 ounces; duratol, 15 grains. Dissolve and add, previously well mixed in the dry state, sulphite of soda, anhydrous, 440 grains; carbonate of soda, anhydrous, 660 grains. When dissolved, add hydroquinone, 60 grains. Add water to make 40 ounces. Use undiluted for contrasty gaslight papers. Dilute with an equal part of water for soft gaslight and bromide papers, plates, and films. For tank development of  $65^{\circ}$  Fahr. Dilute 1 to 1 and develop 12 to 15 minutes. Dilute 1 to 2 and develop 16 to 22 minutes. Dilute 1 to 3 and develop 26 to 34 minutes. Developer without bromide gives blue-black tones; small quantities of bromide give pure black; larger amounts, warm blacks.

*Edinol-Hydro—For Panchromatic Plates.*—Water, 30 ounces, edinol, 120 grains; hydroquinone, 120 grains; sulphite of soda (dry), 768 grains; carbonate potassium, 1344 grains; 10 per cent. bromide potassium solution, 1 dram; 10 per cent. oxalic acid solution, 1 dram. For tank use 1 ounce of above to 15 ounces water; temperature,  $65^{\circ}$  degrees; time, 15 minutes. For tray use 1 ounce above to 4 ounces water.

*Edinol-Hydro Developer—For Plates and Papers (W. S. Davis).*—Water, 8 ounces; edinol, 10 grains; hydrochinon, 15 grains; sulphite of soda (dry), 100 grains; carbonate of soda (dry), 150 grains. May be used full strength for gaslight paper, also for plates and bromide paper if desired. (Normal time of development at  $60-65^{\circ}$  degrees Fahr. Two minutes for plates.) Time of development is increased in proportion to amount of water added.

*Eikonogen*.—An excellent developer for under-exposed portrait negatives. (B. H. Allbee.) Eikonogen, 125 grains; sulphite of soda (dry), 125 grains; carbonate of soda (dry), 125 grains; bromide of potassium, 2 grains; water, 10 ounces. For softer effects add up to an equal volume of water. The image appears quickly and builds up fast.

*Glycin-Metol—For Plates (M. D. Miller)*.—Water, 20 ounces; metol, 60 grains; sulphite of soda, anhydrous, 240 grains; carbonate of soda, anhydrous, 440 grains; glycin, 120 grains. Dilute with an equal volume of water. Wash plate thoroughly before fixing to prevent indelible yellow stain.

*Hydrochinon*.—For over-exposure plates to obtain contrasty negatives (B. H. Allbee). No. 1, water, 8 ounces; sulphite of soda (dry),  $\frac{1}{2}$  ounce; hydrochinon, 80 grains. No. 2, water, 8 ounces; carbonate of soda (dry), 1 ounce; potassium bromide, 40 grains. Take equal parts of No. 1 and No. 2. Temperature, 70 degrees.

*Metol (H. W. Hales)*.—Metol, 60 grains; warm water, 16 ounces; sulphite of soda crystals, 1 ounce; carbonate of soda crystals, 1 ounce. Dissolve metol in warm water, then add the sulphite and carbonate in order named. Cool. Can be used repeatedly. For developing papers add a few drops of 10 per cent. solution of bromide of potassium.

*Metol-Hydroquinone for Orthochromatic Plates*.—Water, 20 ounces; metol, 14 grains; potassium metabisulphite, 18 grains; hydroquinone, 56 grains; sulphite of soda, 1 ounce; carbonate of soda,  $1\frac{3}{4}$  ounces. Use 1 drop of a 10 per cent. potassium bromide solution to each ounce only if necessary.

*Metol-Hydro-Eiko—For Double-coated Ortho Plates (H. S. Hood)*.—Water, 15 ounces; metol, 24 grains; hydroquinone, 24 grains; eikonogen, 24 grains; sulphite of soda (dry),  $\frac{1}{2}$  grain; carbonate of soda (dry), 320 grains; potassium bromide (10 per cent. solution), 4 drops.

*Metol-Hydro-Eikonogen—For Plates (Hood)*.—Water, 150 ounces; metol,  $\frac{1}{2}$  ounce; hydroquinone,  $\frac{1}{2}$  ounce; sulphite of soda (dry),  $5\frac{1}{2}$  ounces; carbonate of soda (dry), 6 ounces. This can be kept in a hard rubber tank for five days before exhausted by oxidation.

*Pyro—For Overtimed Plates (J. D. Elliott)*.—Sulphite of soda, 40° solution, 4 ounces; water, 4 ounces; pyro, 10 grains. Immerse plates in this solution for 20 minutes in the dark; then add to above solution  $\frac{1}{2}$  drachm carbonate of soda, 20° solution. When image appears add one more drachm of the carbonate of soda solution.

*Pyro—For Plates (J. D. Elliott)*.—Sulphite of soda, 40° solution, 4 ounces; carbonate of soda, 20° solution, 4 ounces; pyro, 10 grains.

*Pyro-Metol—For Plates (H. M. Long)*.

A—Water,  $22\frac{1}{2}$  ounces; metabisulphite, 2 drams; metol, 60 grains; pyro, 1 ounce. B—Water, 16 ounces; sulphite of soda, 2 ounces. C—Water, 16 ounces; carbonate of soda, 1 ounce. Normally used 1 ounce of each stock to 16 of water.

*Pyro Soda—For Plates (Mellen)*. No. 1.—Water, 20 ounces; sulphite of soda (crystals), 4 ounces; carbonate of soda, 2 ounces. Dissolve the sulphite first and then add the carbonate.

No. 2.—Water, 6 ounces; pyro, 1 ounce. For correct exposures take 1 dram of No. 2; 1 ounce of No. 1, and add 2 ounces of water. For snapshots, or plates thought to be under-exposed, use 1 dram of No. 2;  $1\frac{1}{2}$  drams of No. 1, and 6 ounces of water. For over-exposure take 2 drams of No. 2, 1 ounce of No. 1 and 6 ounces of water. Or, instead of the 2 drams of No. 2 in this solution use 1 dram of No. 2 and 10 drops of a 10 per cent. solution of potassium bromide.

*Pyro-Metol-Acetone—For Plates (Cramer)*. No. 1.—Water, 60 ounces; metol, 1 ounce; citric acid, 40 grains; pyro, 1 ounce; sulphite of soda (dry), 6 ounces.

No. 2.—Water, 48 ounces; liquid acetone, 12 ounces. For plates take 1 ounce No. 1, 1 ounce No. 2, water 5 ounces. For tank take 1 ounce No. 1, 1 ounce No. 2; water, 13 ounces.

### TANK DEVELOPERS FOR NEGATIVES

*Adurol (Montgomery)*.—Water, 20 ounces; sulphite of soda (anhydrous), 220 grains; carbonate of soda (anhydrous), 220 grains; adurol, 45 grains. For use take 1 ounce of above to 4 ounces water; add 2 drops 10 per cent. bromide solution; temperature, 65 degrees; time, 25 minutes.

*Glycin (Montgomery)*.—Water (hot), 8 ounces; sulphite of soda (anhydrous), 50 grains; carbonate of soda (anhydrous), 240 grains; glycin, 45 grains. For use take 3 ounces of above and 37 ounces water; temperature, 65 degrees; time, 25 minutes.

*Metal-Hydro (Frew)*.—Water, 12 ounces; metol,  $7\frac{1}{2}$  grains; sulphite of soda (anhydrous), 274 grains; hydroquinone, 30 grains; carbonate of soda (anhydrous), 150 grains; bromide of potassium, 2 grains. For use to each ounce of above add 4 ounces of water; temperature, 65 degrees; time, 12 minutes.

*Ortol (Smith)*.—Water, 60 ounces; metabisulphite of potassium, 15 grains, sulphite of soda (anhydrous), 100 grains; carbonate of soda (anhydrous), 100 grains; ortol, 30 grains; temperature, 65 degrees; time, 20 minutes.

*Rodinal (Agfa)*.—Water, 60 ounces; rodinal, 1 ounce; temperature, 65 degrees; time, 25 minutes.

### DEVELOPERS FOR LANTERN SLIDES

*Hydroquinone (B. H. Allbee)*.—No. 1.—Hydroquinone, 150 grains; metabisulphite potash, 10 grains; bromide potassium, 50 grains; water, 20 ounces.

No. 2.—Sulphite of soda (dry), 1 ounce; caustic soda, 100 grains; water, 20 ounces. Take equal parts of No. 1 and No. 2.

*Hydroquinone—For Colder Tones (B. H. Allbee)*. No. 1.—Hydroquinone, 60 grains; sulphite of soda (dry), 1 ounce; citric acid, 10 grains; bromide potassium, 10 grains; water, 10 ounces.

No. 2.—Carbonate of soda (dry), 1 ounce; water, 10 ounces. Use equal parts.

### FIXING BATHS AND HARDENERS

*Acid Fixing Bath (Carbutt)*.—Sulphuric acid, 1 dram; sodium hyposulphite, 16 ounces; sulphite of soda, 2 ounces; chrome alum, 1 ounce; warm water, 64 ounces. To prepare the bath, dissolve the hypo in 48 ounces of water; the sulphite of soda in 6 ounces; mix the sulphuric acid with 2 ounces of the water and pour slowly into the sulphite solution, and then add to the hypo solution. Dissolve the chrome alum in 8 ounces of water; add to the bulk of the solution and the bath is ready for use.

*Acid Fixing Bath (M. D. Miller)*.—Hypo, 8 ounces; water, 1 quart; Lumiere's sodium bisulphite lye, 1 to 2 ounces, to which may be added, if greater hardening is desired, powdered alum, 220 grains.

*Fixing Bath for Lantern Slides (B. H. Allbee)*.—Sulphuric acid, 1 dram, hypo, 16 ounces; sulphite of soda (dry), 1 ounce; chrome alum, 1 ounce; water, 64 ounces.

*Plain Fixing Bath*.—Dissolve 1 pound of sodium hyposulphite in 2 quarts of water or 4 ounces of the hypo in a pint of water, according to the bulk of the solution required.

*Hardener for Fixing Bath (Beach)*.—Water, 40 ounces; sulphite of soda (crystals), 6 ounces; powdered alum, 16 ounces; acetic acid, 40 ounces. Add in the order given and shake well until dissolved. Of

the above add 16 ounces to each gallon of hyposulphite of soda solution, testing 70 to 80 degrees.

*Hardening Negatives.*—Immerse them for a few minutes in formalin, 1 ounce; water, 30 ounces.

## INTENSIFICATION

*Intensifier, One Solution (F. M. Steadman).* No. 1.—Bichloride of mercury,  $\frac{1}{2}$  ounce; water, 10 ounces. No. 2.—Iodide of potassium, 5 drams; water,  $1\frac{1}{2}$  ounces. Add to No. 1. No. 3.—Hyposulphite of soda, 1 ounce; water,  $2\frac{1}{2}$  ounces. Add to the previous mixture. This clears the solution when it is ready for use for local intensification. For tray intensification add more water to slow its action.

*Intensifying with Red Ink (E. M. Cohen).*—Soak the negative well. Put teaspoon of red ink into tray of water and rock until mixed. Immerse negatives face up till well and evenly colored, then without washing put in drying frame. If left in solution too long will be over dense, in which case several trays of clear water will eliminate some of the color.

The intensification is permanent without the danger of negative going bad, as is the case when mercury is used.

*Intensifier—Mercuric Chloride Process.* No. 1.—Mercuric chloride, 200 grains; bromide of potassium, 120 grains; water,  $6\frac{1}{2}$  ounces.

No. 2.—Sulphite of soda, 1 ounce; water, 4 ounces. The well-washed negative, free from hypo, must be thoroughly bleached in No. 1; well washed; and then blackened in No. 2. After blackening it is well washed again.

## REDUCTION

*Reducer, Single Solution (F. M. Steadman).*—Red prussiate of potash, size of pea; hyposulphite of soda, six times that volume; water, 6 ounces (for local reduction  $1\frac{1}{2}$  ounces). When reduced wash thoroughly.

*Reducer—Ammonium Persulphate.*—Ammonium persulphate, 15 grains; water, 1 ounce. The solution should be made just before use. The negative must be perfectly free from hypo or it will be stained by the persulphate. When the desired reduction has been reached, transfer the negative without washing to a 10 per cent. solution of anhydrous sodium sulphite. Wash finally for 15 or 20 minutes.

*Reducer—Farmer's.*—Dissolve 1 ounce of potassium ferricyanide in 9 ounces of water and make up to 10 ounces, forming a 10 per cent. solution. Label this poison. Thoroughly wet the negative to be reduced. Take enough fresh plain hypo fixing bath for the purpose, and add to it enough of the ferricyanide solution to make it a light straw color. The negative to be reduced is immersed in this solution, when it will be seen to lose density. Rock the tray to insure evenness of action. This reducer can also be used for local treatment.

## PRINTING PROCESSES

### *Blue Prints*

*Blue Printing Sensitizing Formulæ (Brown).* A.—Dissolve 110 grains ferric ammonium citrate (green) in 1 ounce of water.

B.—Dissolve 40 grains of potassium ferricyanide in 1 ounce of water. These two solutions are made up separately. They are then mixed together and kept in a stoneware bottle, but the single solution should always be filtered before use. The mixture will retain its good qualities for months if kept from the light.

(Millen).—Potassium ferricyanide, 1 ounce; ammonio-citrate of iron,  $1\frac{1}{2}$  ounces; distilled water, 10 ounces. Mix thoroughly and filter. The solution should have a deep wine color and dry on the paper a



lemon-yellow. If the solution is green and has a precipitate, the ammonio-citrate is old and spoiled. The mixture should be kept from the light.

#### *Bromide Paper*

*Bromide Paper Developers: Hydroquinone-metol.* No. 1.—Water, 10 ounces; hydroquinone, 52 grains; potassium metabisulphite, 18 grains; sulphite of soda, 5 drams; carbonate of soda, 1¼ ounces.

No. 2.—Water, 10 ounces; metol, 30 grains; carbonate of soda, 5 drams; sulphite of soda, 5 drams. One or two drops of a potassium bromide 10 per cent. solution added to 1 ounce of the mixed developer will increase contrast and keep the whites pure. Equal parts of 1 and 2 give excellent prints from a normal negative; one part of 1 and two of 2 give gray prints with maximum half-tone and gradation; two parts of 1 and one of 2 give vigorous prints from soft delicate negatives.

*Amidol* for rich blacks (freshly prepared). Distilled (or boiled) water, 4 ounces; sulphite of soda (crystals), 90 drams; amidol, 10 to 15 grains. Add a drop of 10 per cent. bromide solution to each ounce of developer.

*Sepia Tones: Hypo Alum.*—Hyposulphite of soda, 5 ounces; ground alum, 1 ounce; boiling water, 70 ounces. Dissolve the hypo in the water, and then add the alum slowly. A milk-white solution results which should be decanted when clear. It is not used until cold (about 60° Fahr.).

*Sepia Tones: Sulphide of Sodium.*—The fixed and washed print is treated with one of the following solutions: (1) Potassium ferricyanide, 10 grains; potassium bromide, 10 grains; water, 1 ounce; or (2) potassium ferricyanide, 20 grains; sodium chloride (common salt), 30 grains; water, 1 ounce. The image will be bleached by either of these solutions in a few minutes, the whitish appearance of the deposit being caused by its change into a salt of silver. After 5 minutes in running water apply the sulphuretted solution: Dissolve 3 ounces of sodium monosulphide in 15 ounces of water; boil the solution for about 10 minutes, filter off the black precipitate formed, and when cooled make up to 25 ounces with water. To tone take of the sulphide solution 1 ounce and add water 12 to 20 ounces.

*Red Tones: Copper.*—Dissolve 100 grains of ammonium carbonate in 2 ounces of water, and in this solution dissolve 10 grains of sulphate of copper. Then add 20 grains of potassium ferricyanide. A clear, dark green solution results which gives a red-chalk tone in about 3 minutes. Tone until the deepest shadow is converted, and then wash the print for 10 minutes.

*Green Tones: Vanadium.*—Bleach print in the following: Potassium ferricyanide, 10 grains; ammonium carbonate, 100 grains; water, 1 ounce. Wash well and apply: Ferric chloride, 2 grains; vanadium chloride, 2 grains; ammonium chloride, 4 grains; hydrochloric acid, 5 minims; water, 1 ounce.

*Blue Tones: Iron.*—Bleach print in: Potassium ferricyanide, 10 grains; ammonium carbonate, 100 grains; water, 1 ounce; then tone in ferric chloride, 5 grains; hydrochloric acid, 5 minims; water, 1 ounce.

*To prevent blistering on bromide paper (P. L. Anderson).*—Immerse after fixing and before washing from 10 to 15 minutes in water, 10 ounces; formaldehyde, 1 ounce. A 10 per cent. solution of chrome alum will do equally well.

*To make bromide paper translucent (P. L. Anderson).*—Lay the paper negative face down on a blotter and paint thinly with the following mixture. Give three coats. Turpentine, 3 ounces; powdered resin, 1 ounce; gum elemi, 1 ounce; paraffine wax, ½ ounce. Heat with stirring until it begins to boil. Allow to cool slightly and add turpentine, 3 ounces.

### *Carbon Tissue*

*Carbon Tissue, Sensitizer for (Bennett).*—Potassium bichromate, 4 drams; citric acid, 1 dram; strong ammonia water, about 3 drams; water, 25 ounces; dissolve the bichromate and citric acid in hot water, and add sufficient ammonia to change the orange color of the solution to lemon-yellow. Sensitize for 90 seconds; reducing the water softens the gradation in the print; increasing it to 30 ounces gives more vigor.

*Carbon Lantern Slides.*—Prepare the glass by coating with the following preparation: 180 grains of Nelson's Gelatine No. 1, in 20 ounces water. Add 10 grains bichromate of potash. Dry and allow the plate to be exposed to light for a couple of days to make the coating thoroughly insoluble. Sensitizer for tissue: 1 per cent. to  $1\frac{1}{4}$  per cent. solution of bichromate of potash. Immerse 2 minutes. Print deeply; expose twice as long as ordinary paper print. Develop in hot water as usual.

### *Gum Bichromate*

*Gum Bichromate (Casper Millar).* A.—Gum arabic,  $1\frac{1}{4}$  ounces; water,  $3\frac{1}{2}$  ounces; salicylic acid, 4 grains.

B.—Chrome alum, 45 grains; water,  $3\frac{1}{2}$  ounces. Grind A and B with water and pigment, brush over paper, dry and store.

Suggested formula.—A, 2 ounces; B,  $1\frac{1}{2}$  drams; carbon black, 10 grains; sensitize for 2 minutes in 5 per cent. bichromate solution.

### *Kallitype*

*Kallitype Sensitizer for Black Tones (J. Thomson).*—Distilled water, 1 ounce; ferric oxalate (Merck's or Mallinckrodt's) 15 grains; citrate of iron and ammonia (brown scales), 25 grains; chloride of copper, 8 grains; oxalate of potassium, 35 grains; oxalic acid, 15 grains; silver nitrate, 15 grains; gum arabic, 10 grains. For greater contrast add 1 to 10 drops 5 per cent. bichromate of potassium solution.

*Developer: Stock Solution.*—Distilled water, 1 ounce; silver nitrate, 40 grains; citric acid, 10 grains; oxalic acid, 10 grains. Filter. Normal developer 1 dram stock solution and 7 drams of water.

### *Platinum Papers*

*Platinum Sensitizer (P. L. Anderson).*—Stock solutions: I. Water, hot, distilled, 2 ounces; ferric oxalate, 240 grains; oxalic acid, 16 grains. II. Water, hot, distilled, 2 ounces; ferric oxalate, 240 grains; oxalic acid, 16 grains; potassium chlorate, 4 grains. III. Water, distilled, 19 drams; potassium chloroplatinite, 219 grains ( $=\frac{1}{2}$  ounce). Keep in amber glass bottles or in the dark. For use take: I, 22 mm.; II, 0 mm.; III, 24 mm. Gives very soft prints. Or, I, 12 mm.; II, 10 mm.; III, 24 mm. Results about the same contrast as a P. O. P. print. Or, I, 0 mm.; II, 22 mm.; III, 24 mm. Gives extreme contrast.

Above quantities sufficient for a 10 x 12 sheet of ordinary paper. Very smooth requires less and very rough more, up to 25 per cent. additional. Apply with a soft fitch or camel-hair brush, allow to surface dry, and make bone-dry over a stove or gas-jet. Should dry in not less than five or more than ten minutes.

*Platinum: Sensitizing Gold Bath and Sepia Papers.* A.—Chloroplatinite of potassium, 15 grains; distilled water, 90 minims.

B.—Ferric oxalate, 21 grains; oxalic acid, 2 grains; distilled water, 183 minims. For cold bath paper, mix A and B, and add 15 minims of water. For sepia paper mix A and B and add 15 minims of a 5 per cent. solution of mercuric chloride. The addition of a few grains of potassium chlorate to any of the above gives increased contrast in the print. From 140 to 170 minims of solution are sufficient to coat a sheet of paper 20 x 26 inches.

*Platinum Prints: to Intensify.* A.—Sodium formate, 45 grains: water, 1 ounce.

B.—Platinum perchloride, 10 grains; water, 1 ounce.

C.—For use, take 15 minims each of A and B to 2 ounces of water. Immerse prints until sufficiently intensified, then remove and wash.

*Platinum Prints to Distinguish from Bromide.*—Soak the print in saturated solution of mercuric chloride; a platinum print will not change; a bromide print will bleach.

#### *Salted Papers*

*Salted Paper Prints: Sensitized with the following:*—Silver, 480 grains Troy; water, 11 ounces. Dissolve and pour off 2 ounces, and to the 9 ounces left add strong aqua ammonia to form a precipitate and redissolve the precipitate, then add the remaining 2 ounces which will form another precipitate, to this add 9 drops of nitric acid C. P. Apply this to the paper with a tuft of cotton.

Any good Toning Bath will give good results, such as: Chloride aluminum, 80 grains; bi-carbonate soda, 360 grains; water, 48 ounces. When mixed this will form a flacky hydrate which will settle to the bottom. It can be strained through clean washed muslin. To prepare a small bath for toning, take 12 ounces of the stock solution and add sufficient gold to tone in 8 to 10 minutes. The gold solution must be neutralized with bi-carbonate soda before adding to the above bath. When the prints reach the desired tone throw them into a bath of salt water, made of water, 1 gallon; table salt, 1 ounce.

#### *Printing Out Papers*

*Gold Toning (B. H. Allbee).* No. 1, 10 per cent. solution sulphocyanide of potassium; No. 2, 15 grains chloride of gold in 7½ ounces of water; No. 3, 10 per cent. solution phosphate of soda; No. 4, saturated solution borax. Take No. 1, 1 dram, water, 8 drams; No. 2, 4 drams; No. 3, 1 dram; No. 4, 2 drams. In this put print in dry. Toning should be complete in two minutes. Wash as usual.

*Gold Toning.*—For blue-black tones, for slight strengthening, and for converting rusty black into pure black. Soak print in warm water, lay on warm glass, brush over glycerine and blot off. Pour on few minims of solution of gold chloride (1 grain per dram), and rapidly brush in all directions. When toned, rinse, and sponge back and front with: Metol, 50 grains; sodium sulphite, 1 ounce; potassium carbonate, ½ ounce; water, 20 ounces. Tone in daylight. Do not tone sepias or old prints in this solution.

## MISCELLANEA

*Adhesive for Labels.*—Soak 1 part of the best glue in water until thoroughly swollen, add a little sugar candy, 1 part of gum arabic and 6 parts of water. Boil with constant stirring over a spirit lamp until the whole gets thin. Coat sheets of paper with it; let dry and cut up into convenient sizes.

*Autochromes.—Sensitizing to get more speed (M. G. Lovelace).*—In complete darkness bathe plates in the following solution: Distilled water, 66 cc.; ethyl alcohol pure 90 deg., 33 cc.; dye solution, 2 cc.; ammonia, .30 cc. The dye solution is a mixture of pinachrome, pina verdol and pinacyanol, 1 part of each in 1000 of alcohol. Bathe plates for five minutes and dry away from dust. These plates require a special filter the formula being: Hard gelatine, 3 gms.; distilled water, 100 cc.; filter yellow K, 1 per cent. solution 2.5 cc. Use 1 cc. to each 10 square centimeters of surface. These plates have about five times the speed and it is possible to make snap shots with them if a lens working at F/4.5 and F/5.6 is used.

*Blacking Mixture.*—Dissolve a 4-ounce stick of licorice in 8 ounces of water with the aid of gentle heat. When dissolved rub into the

mixture 1 ounce of burnt sienna in powder, using the back of a spoon for this purpose. When cold, bottle for use.

*Blackening Brass.*—Make two solutions: Copper nitrate, 200 grains; water, 1 ounce. Silver nitrate, 200 grains; water, 1 ounce. Mix the solutions; clean the article well; dip it in the solution for a moment; withdraw it; dry it; and heat it strongly.

*Black, Dead, for Wood.*—Shellac, 40 parts; borax, 20 parts; glycerine, 20 parts; water, 500 parts. When dissolved, add 50 parts aniline black.

*Cleaning Greasy Bottles.*—Wash with benzine, or permanganate of potassium, to which has been added some hydrochloric acid.

Bottles that have contained resinous substances, wash with potash or soda and rinse with alcohol. Bottles that have contained essences, wash with sulphuric acid, then with water.

*Clearing Stained Negatives.*—Dissolve  $\frac{1}{8}$  ounce of pulverized alum in 20 ounces of water and add 1 dram of sulphuric acid. Immerse the stained plate in this solution for a few minutes; remove plate, wash, and then set in the rack to dry.

*Film: to Remove from Glass:* Make two solutions. A.—Sodium fluoride, 6 grains; water, 4 ounces.

B.—Sulphuric acid, 6 drops; water, 1 ounce. Place the negative in solution A for 2 minutes and then place directly in solution B. After another 2 minutes lift the film with the finger from one corner of the plate. It will soon leave the glass.

*Firelight Effects on Developing Paper (H. S. Hood).* No. 1.—Water, 5 drams; copper sulphate, 10 per cent. solution, 15 minims; ammonium carbonate, 10 per cent. solution. Add till precipitate first formed is redissolved.

No. 2.—Water,  $4\frac{1}{2}$  ounces; potassium ferricyanide,  $\frac{6}{10}$  drams. Mix separately and add No. 2 to No. 1. The print will turn bright red. Wash well.

*Ground Glass: Substitutes for.* 1.—Paraffine wax makes an excellent substitute for ground glass if the latter should get broken. Iron the paper onto a sheet of plain glass. It is more transparent than the focusing screen and the image will appear clearer; hence, in exposing allowance must be made for the difference in illumination.

2.—Resin dissolved in wood alcohol and blown over the glass; this must not be scratched; it gives a very fine-grained ground glass effect.

3.—White wax, 120 grains; ether, 1 ounce.

*Ground Glass Varnish:* Sandarac, 90 grains; mastic, 20 grains; ether, 2 ounces. Dissolve the resins in the ether and add benzole  $\frac{1}{2}$  to  $1\frac{1}{2}$  ounces.

*Lens: to Clean.*—The lens should always be kept free from dust or other impurities. To clean it, spread upon a table a clean sheet of paper; take the lens apart, and with a camel-hair brush dust each of the combinations on both sides. If the surfaces of the lenses are very dirty and have lost their polish, make up the following: Nitric acid, 3 drops; alcohol, 1 ounce; distilled water, 2 ounces. Dip a tuft of filtering cotton in this solution, rub each side of the lens, then polish with an absolutely clean chamois. Clean the lens tube before replacing the lenses, each of which should be finally dusted with a camel-hair brush.

*Moonlight Effects on Developing Paper (H. S. Hood).*—Immerse in water, 5 ounces; ferric ammonium citrate, 12 grains; potassium ferricyanide, 12 grains; nitric acid,  $\frac{2}{5}$  drams. Prints will assume a blue color. Wash until whites become clear.

*Mounting Without Cockling (W. S. Davis).*—Coat back of dry print with as strong a solution of warm gelatine (pure table gelatine will do) as can be spread easily. Allow to dry, then attach to mount by dampen-

ing the mount with water, then lay print in desired position; cover with a sheet of bond or smooth paper, and apply a warm flat iron until the gelatine melts. Very effective for thin mounting material, as there is no cockling if the mount contains just the right amount of water when the iron is applied.

*Non-Abrasion Soda Mixture (M. G. Lovelace).*—Sulphite of soda, 1 ounce; carbonate of soda, 370 grains; hypo, 8 grains. A mixture in these proportions may be used in place of sodas for paper; or carbonate of soda, 28.75 grams; hypo, 38.75 grams; water to 500.00 c.c.

*Paste, Starch (A. Lomax).* Powdered starch, 1 ounce; cold water, 12 ounces. Mix smooth with a glass rod, heat to boiling point. Boil half a minute stirring all the time. Use cold.

*Poisons and Antidotes.*—Administer the antidote as soon as possible. If a strong acid or alkali, or cyanide of potassium, has been swallowed, lukewarm water in large quantities should be swallowed at once. Where strong acids or alkalies have not been swallowed, rid the stomach of the poison by vomiting; for this purpose take 25 grains of zinc sulphate in warm water.

*Polished Surfaces: to Photograph.*—Smear the surface with soft putty so as to deaden the reflections. Photograph the article against a black background, and stop off all reflections, allowing the light to come from one direction only. To photograph hollow cut glassware fill with ink or aniline black water dye. Before photographing machinery deaden the bright parts with putty.

*Safe Light for Panchromatic Plates.*—Take old dry plates and coat with the following: Water, 10 ounces; tartrazine, 75 grains; patent blue A, 75 grains; naphthol greens, 75 grains; sulphuric acid, 30 minims. Stain the plates as deeply as possible. Use two plates.

*Stains: to Remove from the Hands.*—Developer stains: solution of citric or oxalic acid. Silver nitrate stains: Water, 4 ounces; chloride of lime, 350 grains; sulphate of soda, 1 ounce. Apply with a brush.

*Tarnished Daguerreotypes, to Restore.*—Remove the silvered plate from the case and place it, image uppermost, under a box lid or other protector from dust, etc. Put a small piece of potassium cyanide into a graduate and pour over it 1 or 2 ounces of water. Hold the daguerreotype by the corner with a pair of pliers, rinse it in clear running water, then pour over it the weak cyanide solution (a 3 per cent. solution is usually employed), and return it to the graduate. Repeat this operation several times until the discoloration quite disappears. Wash well in running water, and then, before the surplus water has time to collect in tears upon the image, begin to dry the plate gradually over a spirit lamp, holding the plate in an inclined position so that it will dry from the uppermost corner. The secret of success is in the use of pure water for the final washings and the drying of the image without check or the formation of tears.

*Test for Hypo:* Potassium permanganate, 2 grains; potassium carbonate, 20 grains; distilled water, 40 ounces. Soak the plate or print to be treated in water for one hour, then remove and add to the water a few drops of the above solution, which will turn a greenish yellow or brown if the water is not free from hypo.

*To Flatten Double-weight Prints (George D. Jopson).* A—9 ounces boiling water;  $\frac{1}{2}$  ounce gelatine. B—3 ounces boiling water;  $\frac{1}{2}$  drachm alum. C—2 drachms oil of cloves. Mix and strain through cheese cloth while hot. To use take a little from the stock and place in a cup. Place cup in hot water until backing is dissolved. Apply very thin to back of print with soft cloth or a tuft of cotton.

# UNITED STATES WEIGHTS AND MEASURES

According to Existing Standards

## LINEAR

	Inches	Feet	Yards	Rods	Fur's	Mi.
12 inches = 1 foot.	12 =	1				
3 feet = 1 yard.	36 =	3 =	1			
5.5 yards = 1 rod.	198 =	16.5 =	5.5 =	1		
40 rods = 1 furlong.	7,920 =	660 =	220 =	40 =	1	
8 furlongs = 1 mile.	63,360 =	5,280 =	1,760 =	320 =	8 =	1

## SURFACE—LAND

	Feet	Yards	Rods	Roods	Acres
144 sq. ins. = 1 sq. ft.					
9 sq. ft. = 1 sq. yd.	9 =	1			
30.25 sq. yds. = 1 sq. rod.	272.25 =	30.25 =	1		
40 sq. rods = 1 sq. rood.	10,890 =	1,210 =	40 =	1	
4 sq. roods = 1 acre.	43,560 =	4,840 =	160 =	4 =	1
640 acres = 1 sq. mile.	27,878,400 =	3,097,600 =	102,400 =	2,560 =	640

## VOLUME—LIQUID

	Gills	Pints	Gallon	Cub. In.
4 gills = 1 pint.				
2 pints = 1 quart.	32 =	8 =	1 =	231
4 quarts = 1 gallon.				

## FLUID

Gallon	Pints	Ounces	Drachms	Minims	Cubic Centimetres
1 =	8 =	128 =	1,024 =	61,440 =	3,785,435
	1 =	16 =	128 =	7,680 =	473,179
		1 =	8 =	480 =	29,574
			1 =	60 =	3,697

16 ounces, or a pint, is sometimes called a fluid pound.

## TROY WEIGHT

Pound	Ounces	Pennyweights	Grains	Grams
1 =	12 =	240 =	5,760 =	373.24
	1 =	20 =	480 =	31.10
		1 =	24 =	1.56

## APOTHECARIES' WEIGHT

lb.	℥	ʒ	℥	gr.	Grams
Pound	Ounces	Drachms	Scruples	Grains	
1 =	12 =	96 =	288 =	5,760 =	373.24
	1 =	8 =	24 =	480 =	31.10
		1 =	3 =	60 =	3.89
			1 =	20 =	1.30
				1 =	.06

The pound, ounce, and grain, are the same as in Troy weight.

## AVOIRDUPOIS WEIGHT

Pound	Ounces	Drachms	Grains (Troy)	Grams
1 =	16 =	256 =	7,000 =	453.60
	1 =	16 =	437.5 =	28.35
		1 =	27.34 =	1.77

## ENGLISH WEIGHTS AND MEASURES

### APOTHECARIES' WEIGHT

20 Grains	= 1 Scruple	= 20 Grains.
3 Scruples	= 1 Drachm	= 60 Grains.
8 Drachms	= 1 Ounce	= 480 Grains.
12 Ounces	= 1 Pound	= 5,760 Grains.

### FLUID MEASURE

60 Minims	= 1 Fluid Drachm	
8 Drachms	= 1 Fluid Ounce	
20 Ounces	= 1 Pint	
8 Pints	= 1 Gallon	

The above weights are usually adopted in formulas.

All Chemicals are usually sold by

### AVOIRDUPOIS WEIGHT

27 <sup>11</sup> / <sub>32</sub> Grains	= 1 Drachm	= 27 <sup>11</sup> / <sub>32</sub> Grains
16 Drachms	= 1 Ounce	= 437 <sup>1</sup> / <sub>2</sub> Grains
16 Ounces	= 1 Pound	= 7,000 Grains

Precious Metals are usually sold by

### TROY WEIGHT

24 Grains	= 1 Pennyweight	= 24 Grains
20 Pennyweights	= 1 Ounce	= 480 Grains
12 Ounces	= 1 Pound	= 5,760 Grains

NOTE.—An ounce of metallic silver contains 480 grains, but an ounce of nitrate of silver contains only 437<sup>1</sup>/<sub>2</sub> grains.

### UNITED STATES FLUID MEASURE

Gal.	Pints.	Ounces.	Drachms.	Mins.	Cub. In.	Grains.	Cub. C.M
1	= 8	= 128	= 1,024	= 61,440	= 231.	= 58,328.886	= 3,785.44
	1	= 16	= 128	= 7,680	= 28.875	= 7,291.1107	= 473.18
		1	= 8	= 480	= 1.8047	= 455.6944	= 29.57
			1	= 60	= 0.2256	= 56.9618	= 3.70

### IMPERIAL BRITISH FLUID MEASURE

Gal.	Pints.	Ounces.	Drachms.	Mins.	Cub. In.	G.ains.	Cub. C.M
1	= 8	= 160	= 1,280	= 76,800	= 277.27384	= 70,000	= 4,543.732
	1	= 20	= 160	= 9,600	= 34.65923	= 8,750	= 567.966
		1	= 8	= 480	= 1.73296	= 437.5	= 28.398
			1	= 60	= 0.21662	= 54.69	= 3.550

# METRIC SYSTEM OF WEIGHTS AND MEASURES

## MEASURES OF LENGTH

DENOMINATIONS AND VALUES		EQUIVALENTS IN USE
Myriameter.....	10,000 meters.	6.2137 miles.
Kilometer.....	1,000 meters.	.62137 mile, or 3,280 ft. 10 ins.
Hectometer.....	100 meters.	328. feet and 1 inch.
Dekameter.....	10 meters.	393.7 inches.
Meter.....	1 meter.	39.37 inches.
Decimeter.....	1-10th of a meter.	3.937 inches.
Centimeter.....	1-100th of a meter.	.3937 inch.
Millimeter.....	1-1000th of a meter.	.0394 inch.

## MEASURES OF SURFACE

DENOMINATIONS AND VALUES		EQUIVALENTS IN USE
Hectare.....	10,000 square meters.	2.471 acres.
Are.....	100 square meters.	119.6 square yards.
Centare.....	1 square meter.	1,550. square inches.

## MEASURES OF VOLUME

DENOMINATIONS AND VALUES			EQUIVALENTS IN USE	
NAMES	No. of Liters	CUBIC MEASURES	DRY MEASURE	WINE MEASURE
Kiloliter or stere.....	1,000	1 cubic meter.	1.308 cubic yards.	264.17 gallons.
Hectoliter.....	100	1-10th cubic meter.	2 bu. and 3.35 pecks.	26.417 gallons.
Dekaliter.....	10	10 cubic decimeters.	9.08 quarts.	2.6417 gallons.
Liter.....	1	1 cubic decimeter.	.908 quart.	1.0567 quarts.
Deciliter.....	1-10	1-10th cubic decimeter.	6.1023 cubic inches.	.845 gill.
Centiliter.....	1-100	10 cubic centimeters	.6102 cubic inch.	.338 fluid oz.
Milliliter.....	1-1000	1 cubic centimeter.	.061 cubic inch.	.27 fl. drm.

## WEIGHTS

DENOMINATIONS AND VALUES			EQUIVALENTS IN USE
NAMES	Number of Grams	WEIGHT OF VOLUME OF WATER AT ITS MAXIMUM DENSITY	AVOIRDUPOIS WEIGHT
Millier or Tonneau.....	1,000,000	1 cubic meter.	2204.6 pounds.
Quintal.....	100,000	1 hectoliter.	220.46 pounds.
Myriagram.....	10,000	10 liters.	22.046 pounds.
Kilogram or Kilo.....	1,000	1 liter.	2.2046 pounds.
Hectogram.....	100	1 deciliter.	3.5274 ounces.
Dekagram.....	10	10 cubic centimeters.	.3527 ounce.
Gram.....	1	1 cubic centimeter.	15.432 grains.
Decigram.....	1-10	1-10th of a cubic centimeter.	1.5432 grain.
Centigram.....	1-100	10 cubic millimeters.	.1543 grain.
Milligram.....	1-1000	1 cubic millimeter.	.0154 grain.

For measuring surfaces, the square dekameter is used under the term of ARE; the hectare, or 100 ares, is equal to about  $2\frac{1}{2}$  acres. The unit of capacity is the cubic decimeter or LITER, and the series of measures is formed in the same way as in the case of the table of lengths. The cubic meter is the unit of measure for solid bodies, and is termed STERE. The unit of weight is the GRAM, which is the weight of one cubic centimeter of pure water weighed in a vacuum at the temperature of 4 deg. Cent. or 39.2 deg. Fahr., which is about its temperature of maximum density. In practice, the term cubic centimeter, abbreviated c.c., is generally used instead of milliliter, and cubic meter instead of kiloliter.



## THE CONVERSION OF FRENCH (METRIC) INTO ENGLISH MEASURE

1 cubic centimeter	=	17 minims			
2 cubic centimeters	=	34 "			
3 "	=	51 "			
4 "	=	68 "	or 1 dram	8 minims	
5 "	=	85 "	" 1 "	25 "	
6 "	=	101 "	" 1 "	41 "	
7 "	=	118 "	" 1 "	58 "	
8 "	=	135 "	" 2 drams	15 "	
9 "	=	152 "	" 2 "	32 "	
10 "	=	169 "	" 2 "	49 "	
20 "	=	338 "	" 5 "	38 "	
30 "	=	507 "	" 1 ounce	0 dram	27 minims
40 "	=	676 "	" 1 "	3 drams	16 "
50 "	=	845 "	" 1 "	6 "	5 "
60 "	=	1014 "	" 2 ounces	0 "	54 "
70 "	=	1183 "	" 2 "	3 "	43 "
80 "	=	1352 "	" 2 "	6 "	32 "
90 "	=	1521 "	" 3 "	1 "	21 "
100 "	=	1690 "	" 3 "	4 "	10 "
1000 "	=	1 liter = 34 fluid ounces nearly, or $2\frac{1}{8}$ pints.			

## THE CONVERSION OF FRENCH (METRIC) INTO ENGLISH WEIGHT

The following table, which contains no error greater than one-tenth of a grain, will suffice for most practical purposes:

1 gram	=	15 $\frac{2}{5}$ grains.			
2 grams	=	30 $\frac{4}{5}$ "			
3 "	=	46 $\frac{1}{5}$ "			
4 "	=	61 $\frac{4}{5}$ "	.....or	1 dram	14 $\frac{4}{5}$ grain
5 "	=	77 $\frac{1}{5}$ "	....."	1 "	17 $\frac{1}{5}$ grains
6 "	=	92 $\frac{3}{5}$ "	....."	1 "	32 $\frac{3}{5}$ "
7 "	=	108 "	....."	1 "	48 "
8 "	=	123 $\frac{2}{5}$ "	....."	2 drams	3 $\frac{2}{5}$ "
9 "	=	138 $\frac{4}{5}$ "	....."	2 "	18 $\frac{4}{5}$ "
10 "	=	154 $\frac{2}{5}$ "	....."	2 "	34 $\frac{2}{5}$ "
11 "	=	169 $\frac{4}{5}$ "	....."	2 "	49 $\frac{4}{5}$ "
12 "	=	185 $\frac{1}{5}$ "	....."	3 "	51 $\frac{1}{5}$ "
13 "	=	200 $\frac{3}{5}$ "	....."	3 "	20 $\frac{3}{5}$ "
14 "	=	216 "	....."	3 "	36 "
15 "	=	231 $\frac{2}{5}$ "	....."	3 "	51 $\frac{2}{5}$ "
16 "	=	247 "	....."	4 "	7 "
17 "	=	262 $\frac{2}{5}$ "	....."	4 "	22 $\frac{2}{5}$ "
18 "	=	277 $\frac{4}{5}$ "	....."	4 "	37 $\frac{4}{5}$ "
19 "	=	293 $\frac{1}{5}$ "	....."	4 "	53 $\frac{1}{5}$ "
20 "	=	308 $\frac{3}{5}$ "	....."	5 "	8 $\frac{3}{5}$ "
30 "	=	463 "	....."	7 "	43 "
40 "	=	617 $\frac{1}{5}$ "	....."	10 "	17 $\frac{1}{5}$ "
50 "	=	771 $\frac{3}{5}$ "	....."	12 "	51 $\frac{3}{5}$ "
60 "	=	926 "	....."	15 "	26 "
70 "	=	1080 $\frac{1}{5}$ "	....."	18 "	01 $\frac{1}{5}$ "
80 "	=	1234 $\frac{3}{5}$ "	....."	20 "	34 $\frac{3}{5}$ "
90 "	=	1389 "	....."	23 "	9 "
100 "	=	1543 $\frac{1}{5}$ "	....."	25 "	43 $\frac{1}{5}$ "
1000 "	=	1 kilogram = 32 oz., 1 dr., 12 $\frac{2}{5}$ gr.			

**THE ELEMENTS:**  
**THEIR NAMES, SYMBOLS, AND ATOMIC WEIGHTS**  
**OXYGEN STANDARD.**

Compiled by **HENRY F. RAESS.**

1915					
Aluminum...Al	27.10	Holmium....Ho	163.50	Rhodium...Rh	102.90
Antimony...Sb	120.20	Hydrogen...H	1.008	Rubidium...Rb	85.45
Argon.....A	39.88	Indium.....In	114.80	Ruthenium..Ru	101.70
Arsenic....As	74.96	Iodine.....I	126.92	Samarium...Sa	150.40
Barium...Ba	137.37	Iridium.....Ir	193.10	Scandium...Sc	44.10
Bismuth...Bi	208.00	Iron.....Fe	55.84	Selenium...Se	79.20
Boron.....B	11.00	Krypton....Kr	82.92	Silicon.....Si	28.30
Bromine...Br	79.92	Lanthanum...La	139.00	Silver.....Ag	107.88
Cadmium...Cd	112.40	Lead.....Pb	207.10	Sodium.....Na	23.00
Caesium...Cs	132.81	Lithium....Li	6.94	Strontium...Sr	87.63
Calcium...Ca	40.07	Lutecium....Lu	174.00	Sulphur....S	32.07
Carbon...C	12.00	Magnesium...Mg	24.32	Tantalum...Ta	181.50
Cerium...Ce	140.25	Manganese...Mn	54.93	Tellurium...Te	127.50
Chlorine...Cl	35.46	Mercury....Hg	200.60	Terbium...Tb	159.20
Chromium..Cr	52.00	Molybdenum..Mo	96.00	Thallium...Tl	204.00
Cobalt....Co	58.97	Neodymium...Nd	144.30	Thorium...Th	232.40
Columbium.Cb	93.50	Neon.....Ne	20.20	Thulium...Tm	168.50
Copper....Cu	63.57	Nickel.....Ni	58.68	Tin.....Sn	119.00
Dysprosium Dy	162.50	Niton.....Nt	222.40	Titanium...Ti	48.10
Erbium....Er	167.70	Nitrogen....N	14.01	Tungsten...W	184.00
Europium..Eu	152.00	Osmium.....Os	190.90	Uranium...U	238.50
Fluorine...F	19.00	Oxygen.....O	16.00	Vanadium...V	51.00
Gadolinium.Gd	157.30	Palladium...Pd	106.70	Xenon.....Xe	130.20
Gallium...Ga	69.90	Phosphorus..P	31.04	Ytterbium...Yb	173.50
Germanium.Ge	72.50	Platinum....Pt	195.20	Yttrium....Yt	89.00
Glucinum...Gl	9.10	Potassium...K	39.10	Zinc.....Zn	65.37
Gold.....Au	197.20	PraseodymiumPr	140.60	Zirconium...Zr	90.60
Helium....He	3.96	Radium.....Ra	226.40		

**TABLE OF COMPARATIVE PLATE SPEED**  
**NUMBERS**

H & D	Watkins P No.	Wynne F No.	H & D	Watkins P No.	Wynne F No.
10	15	24	220	323	114
20	30	28	240	352	120
40	60	49	260	382	124
80	120	69	280	412	129
100	147	77	300	441	134
120	176	84	320	470	138
140	206	91	340	500	142
160	235	103	380	558	150
200	294	109	400	588	154

The above Watkins and Wynne numbers are equivalent to the H and D, only when the latter is determined in accordance with the directions of Hurter and Driffeld, that is with pyro-soda developer and using the straight portion only of the density curve.

To convert H and D into Watkins: Multiply H and D by 50 and divide by 34. For all practical purposes the Watkins P number is 1½ times H and D.

To convert Watkins into Wynne F Nos.: Extract the square root and multiply by 6.4.

The above methods have been approved by the Watkins Meter Company and the Infallible Exposure Meter Company.

**TABLE OF SOLUBILITIES OF THE MORE COMMON CHEMICALS  
USED IN PHOTOGRAPHY**

Sol.—Soluble. V.S.—Very Soluble. S.S.—Slightly Soluble.  
Dec.—Decomposed. Insol.—Insoluble.

	One Part is Soluble in—Parts of Water			One Part is Soluble in—Parts of Water	
	Cold	Hot		Cold	Hot
Acetone, Sulphite...	1	..	Potassium, Bicarbonate.....	3.5	Dec.
Acid, Citric.....	0.75	0.50	Potassium, Bichromate.....	10	1
Acid, Gallic.....	100	0.3	Potassium, Bromide.....	1.5	1
Acid, Oxalic.....	9	0.3	Potassium, Carbonate.....	.9	0.50
Acid, Pyrogallic....	2	V.S.	Potassium, Chloroplatinite.....	6	V.S.
Acid, Tannic.....	0.6	..	Potassium, Cyanide.....	1	0.5
Acid, Tartaric.....	0.75	.5	Potassium, Ferricyanide.....	2.5	1.3
Alum.....	8	.25	Potassium, Ferrocyanide.....	3	1.5
Alum, Chrome.....	6	Dec.	Potassium, Iodide...	0.75	0.5
Aluminum, Chloride.	0.25	V.S.	Potassium, Metabisulphite.....	Sol.	Dec.
Amidol.....	4	V.S.	Potassium, Oxalate..	3	2
Ammonium, Bichromate.....	5	.25	Potassium, Permanganate.....	16	10
Ammonium, Bromide.....	1.3	0.7	Potassium, Persulphate.....	50	Dec.
Ammonium, Carbonate.....	4	Dec.	Potassium, Sulphocyanide.....	1	0.5
Ammonium, Citrate.	0.5	V.S.	Pyrocatechin.....	1.25	V.S.
Ammonium, Iodide..	0.75	V.S.	Rochelle Salt.....	1.5	V.S.
Ammonium, Nitrate.	1	V.S.	Silver, Nitrate.....	.75	.25
Ammonium, Persulphate.....	1.5	Dec.	Sodium, Acetate....	3	.5
Ammonium, Sulphocyanide.....	0.6	V.S.	Sodium, Bicarbonate	12	Dec.
Borax.....	12.5	2	Sodium, Bisulphite..	V.S.	..
Cadmium, Bromide.	1	V.S.	Sodium, Bromide...	1.25	1
Cadmium, Chloride.	0.7	V.S.	Sodium, Carbonate (dry).....	6	2.2
Cadmium, Iodide...	1	.75	Sodium, Carbonate (crys't).....	1.5	V.S.
Caustic Potash—Pot. Hydrate....	0.5	.25	Sodium, Chloride...	3	2.5
Caustic Soda—Soda Hydrate.....	1.5	.5	Sodium, Citrate....	1	.5
Copper, Chloride....	1	.75	Sodium, Hyposulphite.....	1.5	1
Copper, Sulphate...	3	1	Sodium, Iodide.....	.5	.3
Edinol.....	1	5	Sodium, Phosphate..	6.7	1
Gold, Chloride.....	V.S.	V.S.	Sodium, Sulphide...	V.S.	V.S.
Hydroquinone.....	17	..	Sodium, Sulphite (dry).....	4	2
Ferric, Chloride....	0.75	.5	Sodium, Sulphite (crys't).....	2.2	1
Ferric, Amm. Citrate.....	4	..	Sodium, Tungstate..	8-12	S.
Ferric, Potassium Oxalate.....	15	0.85	Uranium, Chloride..	V.S.	V.S.
Ferric, Sodium Oxalate.....	1.69	0.55	Uranium, Nitrate...	.5	.25
Ferrous, Sulphate...	1.5	.05	Uranium, Sulphate..	.5	.25
Ferrous, Oxalate....	Insol.	..			
Lead, Acetate.....	2	1			
Lead, Nitrate.....	2	.7			
Mercury, Bichloride.	18	2			
Metol.....	Sol.				
Ortol.....	Sol.				

**"UNIFORM SYSTEM" NUMBERS FOR STOPS FROM**

$$\frac{f}{1} \text{ TO } \frac{f}{100}$$

In the following table Mr. S. A. Warburton calculated the exposure necessary with every stop from  $\frac{f}{1}$  to  $\frac{f}{100}$  compared with the unit stop of the "uniform system" of the Photographic Society of Great Britain. The figures which are underlined show in the first column what  $\frac{f}{a}$  must be in order to increase the exposure in geometrical ratio from  $\frac{f}{4}$ , the intermediate numbers showing the uniform system number for any other aperture.

<u>f</u>	U. S. No.	f	U. S. No.	f	U. S. No.
<u>1</u>	$\frac{1}{16}$	15	14.06	58	210.25
<u>1<math>\frac{1}{4}</math></u>	.097	16	16	59	217.56
1.414	$\frac{1}{8}$	17	18.06	60	225.00
<u>1<math>\frac{1}{2}</math></u>	.140	18	20.25	61	232.56
1 $\frac{3}{4}$	.191	19	22.56	62	240.25
<u>2</u>	$\frac{1}{4}$	20	25.00	63	248.06
2 $\frac{1}{4}$	.316	21	27.56	64	256
2 $\frac{1}{2}$	.390	22	30.25	65	264.06
<u>2.828</u>	$\frac{1}{2}$	22.62	32	66	272.25
2 $\frac{3}{4}$	.472	23	33.06	67	280.56
<u>3</u>	.562	24	36.00	68	289.00
3 $\frac{1}{4}$	.660	25	39.06	69	297.56
3 $\frac{1}{2}$	.765	26	42.25	70	306.25
3 $\frac{3}{4}$	.878	27	45.56	71	15.06
<u>4</u>	1	28	49.00	72	324.00
4 $\frac{1}{4}$	1.12	29	52.56	73	333.06
4 $\frac{1}{2}$	1.26	30	56.25	74	342.25
4 $\frac{3}{4}$	1.41	31	60.06	75	351.56
<u>5</u>	1.56	32	64	76	361.00
5 $\frac{1}{4}$	1.72	33	68.06	77	370.56
5 $\frac{1}{2}$	1.89	34	72.25	78	380.25
<u>5.656</u>	2	35	76.56	79	390.06
5 $\frac{3}{4}$	2.06	36	81.00	80	400.00
<u>6</u>	2.25	37	85.56	81	410.06
6 $\frac{1}{4}$	2.44	38	90.25	82	420.25
6 $\frac{1}{2}$	2.64	39	95.06	83	430.56
6 $\frac{3}{4}$	2.84	40	100.00	84	440.00
<u>7</u>	3.06	41	105.06	85	451.56
7 $\frac{1}{4}$	3.28	42	110.25	86	462.25
7 $\frac{1}{2}$	3.51	43	115.56	87	473.06
7 $\frac{3}{4}$	3.75	44	121.00	88	484.00
<u>8</u>	4	45	126.56	89	495.06
8 $\frac{1}{4}$	4.25	45.25	128	90	506.25
8 $\frac{1}{2}$	4.51	46	132.25	90.50	512
8 $\frac{3}{4}$	4.78	47	138.06	91	517.56
<u>9</u>	5.06	48	144.00	92	529.00
9 $\frac{1}{4}$	5.34	49	150.06	93	540.56
9 $\frac{1}{2}$	5.64	50	156.25	94	552.25
9 $\frac{3}{4}$	5.94	51	162.56	95	564.06
<u>10</u>	6.25	52	169.00	96	576.00
11	7.56	53	175.56	97	588.06
11.31	8	54	182.25	98	600.25
<u>12</u>	9.00	55	189.06	99	612.56
13	10.56	56	196.00	100	625
14	12.25	57	203.06		



THE BENT TREES AT NARRABEEN.

Harold Cazneaux.



**THE REFLECTING POWER OF VARIOUS SURFACES  
ACCORDING TO MAX FRANK**

Translated by Henry F. Raess

Mirror.....	0.923	The moon.....	0.170
Freshly fallen snow.....	0.783	Light red.....	0.162
White paper.....	0.700	Dark green.....	0.101
Light orange paper.....	0.548	Dark earth.....	0.079
Light green paper.....	0.465	Dark blue.....	0.065
Light yellow paper.....	0.400	Black paper.....	0.045
Light blue paper.....	0.300	Black cloth.....	0.012
White sandstone.....	0.237	Black velvet.....	0.004
Dark yellow.....	0.200		

**STRENGTH OF VARIOUS LIGHTS, ACCORDING TO EDER  
COMPILED BY HENRY F. RAESS**

Sun at zenith.....	100.000-160.000
Flaming arc light.....	2000-3000
Electric arc light.....	400-1000 and higher
Nernst projection lamp, 220 volts.....	1000
"    "    "    110    ".....	500
Mercury vapor lamp.....	300-400
Electric incandescent light, metallic filament.....	25-50
Electric incandescent light, carbon filament.....	8-32 and higher
Magnesium ribbon burning 0.0074 gm. (about 1-10 grain) per second.....	125
Calcium light, low pressure.....	23-90
"    "    high    "    52 lbs.....	790
Acetylene gas light.....	60-100
"    "    "    with compressed air.....	100-400
Incandescent gas light.....	60-85
"    "    "    with compressed air.....	100-400
Gas flame, argand burner.....	16-20
"    "    fish tail jet.....	6-10
Oil lamp.....	10-11
"    "    with oxygen.....	60
Petroleum lamp, round burner, 25 m-m (1 in.) diam..	14
Petroleum lamp, round burner, 15 m-m (about 1-2 in.) diam.....	6.5
Petroleum lamp, flat burner.....	5-7
Normal paraffine candle.....	1
Tallow candle.....	0.7-0.9
Full moon.....	0.333-0.166

## TABLE FOR CALCULATING DISTANCES IN ENLARGING OR REDUCING

*From The British Journal Photographic Almanac*

Focus of Lens	Times of Enlargement and Reduction							
Inches	1 Inch	2 Inches	3 Inches	4 Inches	5 Inches	6 Inches	7 Inches	8 Inches
2.....	4 4	6 3	8 $2\frac{2}{3}$	10 $2\frac{1}{2}$	12 $2\frac{2}{5}$	14 $2\frac{1}{3}$	16 $2\frac{2}{7}$	18 $2\frac{1}{4}$
$2\frac{1}{2}$ .....	5 5	$7\frac{1}{2}$ $3\frac{3}{4}$	10 $3\frac{1}{3}$	$12\frac{1}{2}$ $3\frac{1}{8}$	15 3	$17\frac{1}{2}$ $2\frac{9}{10}$	20 $2\frac{6}{7}$	$22\frac{1}{2}$ $2\frac{3}{16}$
3.....	6 6	9 $4\frac{1}{2}$	12 4	15 $3\frac{3}{4}$	18 $3\frac{3}{5}$	21 $3\frac{1}{2}$	24 $3\frac{3}{7}$	27 $3\frac{3}{8}$
$3\frac{1}{2}$ .....	7 7	$10\frac{1}{2}$ $5\frac{1}{4}$	14 $4\frac{2}{3}$	$17\frac{1}{2}$ $4\frac{3}{4}$	21 $4\frac{1}{5}$	$24\frac{1}{2}$ $4\frac{1}{12}$	28 4	$31\frac{1}{2}$ $3\frac{9}{10}$
4.....	8 8	12 6	16 $5\frac{1}{3}$	20 5	24 $4\frac{4}{5}$	28 $4\frac{2}{3}$	32 $4\frac{4}{7}$	36 $4\frac{1}{2}$
$4\frac{1}{2}$ .....	9 9	$13\frac{1}{2}$ $6\frac{3}{4}$	18 6	$22\frac{1}{2}$ $5\frac{3}{5}$	27 $5\frac{2}{5}$	$31\frac{1}{2}$ $5\frac{1}{4}$	36 $5\frac{1}{7}$	$40\frac{1}{2}$ $5\frac{1}{16}$
5.....	10 10	15 $7\frac{1}{2}$	20 $6\frac{2}{3}$	25 $6\frac{1}{4}$	30 6	35 $5\frac{5}{6}$	40 $5\frac{5}{7}$	45 $5\frac{5}{8}$
$5\frac{1}{2}$ .....	11 11	$16\frac{1}{2}$ $8\frac{1}{4}$	22 $7\frac{1}{3}$	$27\frac{1}{2}$ $6\frac{4}{5}$	33 $6\frac{1}{2}$	$38\frac{1}{2}$ $6\frac{5}{12}$	44 $6\frac{2}{7}$	$49\frac{1}{2}$ $6\frac{3}{16}$
6.....	12 12	18 9	24 8	30 $7\frac{1}{2}$	36 $7\frac{1}{5}$	42 7	48 $6\frac{6}{7}$	54 $6\frac{3}{4}$
7.....	14 14	21 $10\frac{1}{2}$	28 $9\frac{1}{3}$	35 $8\frac{3}{4}$	42 $8\frac{2}{5}$	49 $8\frac{1}{6}$	56 8	63 $7\frac{1}{8}$
8.....	16 16	24 12	32 $10\frac{2}{3}$	40 10	48 $9\frac{3}{5}$	56 $9\frac{1}{3}$	64 $9\frac{1}{7}$	72 9
9.....	18 18	27 $13\frac{1}{2}$	36 12	45 $11\frac{1}{4}$	54 $10\frac{4}{5}$	63 $10\frac{1}{2}$	72 $10\frac{2}{7}$	81 $10\frac{1}{8}$

The object of this table is to enable any manipulator who is about to enlarge (or reduce) a copy any given number of times to do so without troublesome calculation. It is assumed that the photographer knows exactly what the focus of his lens is, and that he is able to measure accurately from its optical center. The use of the table will be seen from the following illustration: A photographer has a *carte* to enlarge to four times its size, and the lens he intends employing is one of 6 inches equivalent focus. He must therefore look for 4 on the upper horizontal line and for 6 on the first vertical column and carry his eye to where these two join, which will be  $30\text{-}7\frac{1}{2}$ . The greater of these is the distance the sensitive plate must be from the center of the lens; and the lesser, the distance of the picture to be copied. To *reduce* a picture any given number of times, the same method must be followed; but in this case the greater number will represent the distance between the lens and the picture to be copied, the latter that between the lens and the sensitive plate. This explanation will be sufficient for every case of enlargement or reduction.

If the focus of the lens be 12 inches, as this number is not in the column of focal lengths, look out for 6 in this column and multiply by 2, and so on with any other numbers.



**TABLES OF DISTANCES AT AND BEYOND WHICH ALL OBJECTS  
ARE IN FOCUS WHEN SHARP FOCUS IS SECURED ON  
INFINITY**

Focal Length of Lens in Inches	Ratio marked on Stops													
	f/4	f/5.6	f/6	f/7	f/8	f/10	f/11	f/15	f/16	f/20	f/22	f/32	f/44	f/6
	Number of feet after which all is in focus													
4	33	24	22	19	17	13	12	9	8	7	7	4	3	2
4½	38	27	25	21	19	15	14	10	10	7	6	5	3½	2½
4¾	42	30	28	24	21	17	15	11	11	8½	7½	5½	4	3
5	47	34	31	27	24	19	17	12	12	9½	8½	6	5	3
5	52	36	35	30	26	21	19	14	13	10½	9½	6½	5½	3½
5½	57	40	38	33	28	23	21	15	14	11½	10½	7	5½	3½
5¾	63	45	43	36	31	25	23	17	15	12½	11½	7½	6	4
6	68	50	46	38	34	27	25	18	17	13½	13	8½	6½	4
6	75	54	50	42	38	30	28	20	19	15	14	9	7	4½
6½	81	58	54	46	40	32	29	22	20	16	15	10	7½	5
6¾	87	62	58	50	44	35	32	23	22	17½	16	11	8	5½
7	94	67	63	54	47	38	34	25	24	19	17	12	8½	6
7	101	72	68	58	51	40	37	27	25	20	18	12½	9	6
7¼	109	78	73	62	54	44	39	29	27	22	20	13½	10	6½
7½	117	83	78	64	58	47	42	31	29	24	21	14½	10½	7
7¾	124	90	83	71	62	50	45	33	31	25	22	15½	11	7½
8	132	96	88	76	68	52	48	36	32	28	24	16	12	8
8¼	141	100	94	80	71	56	51	37	35	29	25	17½	12½	8½
8½	150	104	100	84	76	60	56	40	38	30	27	19	13½	9
8¾	156	111	104	89	78	63	57	42	39	32	29	20	14	10
9	168	120	112	96	84	67	61	45	42	34	31	21	15	10½
9¼	180	127	116	101	90	71	65	47	45	35	32	22	16	11
9½	190	133	125	107	95	75	68	50	47	37	34	24	17	12
9¾	197	141	131	113	99	79	72	52	50	39	36	25	18	12½
10	208	148	140	120	104	83	75	55	52	42	38	26	19	13

If sharp focus is secured on any of the distances shown, then, with the stop indicated all objects are in focus from half the distance focused on up to infinity.

**LENGTH OF STUDIO**

**REQUIRED FOR LENSES OF DIFFERENT FOCAL LENGTHS  
FROM 6 TO 8 FEET IS ALLOWED FOR THE CAMERA AND  
OPERATOR**

From "Photographic Lenses" by BECK and ANDREWS

Focus of Lens	Size	Kind of Portrait	Length of Studio	Dist. of Lens from Object
Inches 6	Carte de Visite 3¼x4¼	Full Length	In Feet 18 to 20	In Feet 11 to 12
		Bust	22 to 25	14 to 15
7½	Carte de Visite	Full Length	24 to 28	17 to 19
		Bust	10 to 15	5
8½	Carte de Visite	Full Length	20 to 23	12 to 13
		Bust	12 to 17	7
9½	Cabinet and smaller groups	Full Length	25 to 30	17 to 18
		Bust	13 to 20	8
11	Cabinets, panels and 6½x8½ groups	Full Length	32 to 40	23 to 24
		Bust	14 to 20	7
14½	10x12 portraits or groups	Full Length	20 to 25	13
		Bust	14 to 20	7
19	16x20 portraits or groups	Full Length	25 to 30	14
		Bust	14 to 20	8

# American Photographic Societies

This list is compiled from information received from an inquiry form sent to the societies during the latter half of 1915. It includes many societies not given in the 1915 list, but falls short of completeness as a record of the photographic societies of America. Secretaries of societies not here listed are urged to send us particulars of their organization so that the list may be fully representative of society activities.—Editor.

- AKRON CAMERA CLUB**—Akron, Ohio. Headquarters, Y. M. C. A. Building. Established 1890. Membership, 50. Date of meetings, second and fourth Wednesday of each month. *President*, H. A. Hoffman; *Secretary*, Louis D. Allen, 878 N. Market Street. Date of annual exhibition, February.
- AMERICAN INSTITUTE PHOTOGRAPHIC SECTION**—New York City. Headquarters, 322-324 West 23d Street. Established March 26, 1859. Stated meetings, first and third Mondays of each month. No meetings during Summer months. *Chairman*, Oscar G. Mason; *Vice-Chairman*, Robert A. B. Dayton; *Treasurer*, James Y. Watkins; *Secretary*, John W. Bartlett, M.D., F.R.P.S., 149 West 94th Street.
- AMERICAN LANTERN SLIDE INTERCHANGE**—New York. Principal office, 233 Broadway. Organized 1885. *General Manager*, F. C. Beach. Membership, 17 clubs. *Board of Managers*, F. C. Beach, New York; H. W. Schonewolf, Buffalo, N. Y.; O. C. Reiter, Pittsburg, Pa.; S. S. Johnson, Orange, N. J.; W. H. Rau, Philadelphia, Pa. Annual meeting, January of each year.
- BALTIMORE CAMERA CLUB, INC.**—Headquarters, 1121 Bolton Street, Baltimore, Md. Organized in April, 1912. *President*, J. E. Orrison, M.D.; *Vice-President*, John P. Jones; *Secretary*, C. J. Rodgers; *Treasurer*, Joseph B. Legg. Meeting every Tuesday night.
- BERKSHIRE PHOTOGRAPHIC SOCIETY**—Pittsfield, Mass. *Chairman*, Miss Fredrika Cronyn, 34 North Street, Pittsfield, Mass.; *Treasurer*, Miss Martha P. Langley, Pittsfield, Mass.; *Director of Portfolios*, R. E. Schouler, North Adams, Mass. Portfolios of prints circulated monthly with contributions and criticisms by each member.
- BOSTON CAMERA CLUB**—Boston, Mass. Established 1881. Incorporated 1886. Membership, 75. *President*, P. Hubbard; *Secretary*, John H. Thurston, 50 Bromfield Street.
- BOSTON PHOTO CLAN**—Organized July, 1911. Headquarters, The Garo Studio, 739 Bowleson Street. Membership 9.
- BOSTON YOUNG MEN'S CHRISTIAN UNION CAMERA CLUB**—Boston, Mass. Headquarters, 48 Boylston Street, Boston. Organized 1908. *President*, Howard I. Saunders; *Vice-President*, Henry C. Shaw; *Treasurer*, H. C. Channen; *Secretary*, Louis Astrella. Meetings first Tuesday each month at club rooms, 48 Boylston Street.
- BRITISH COLUMBIA AMATEUR PHOTOGRAPHIC SOCIETY**—Orpheum Building, Vancouver, Canada. Organized May 1, 1914. *Secretary-Treasurer*, C. James Duncan. Meetings every Monday evening.
- BUFFALO CAMERA CLUB**—Buffalo, N. Y. Headquarters, Kinne Building, corner Main and Utica Streets. Annual election of officers, fourth Thursday in April; regular meeting nights, second and fourth Thursdays of each month. *President*, Hugh Kerr Thomas; *Vice-President*, Emil Strub; *Secretary*, Ward L. Conklin, 49 Niagara Street.
- CALIFORNIA CAMERA CLUB**—San Francisco, Cal. Headquarters, 833 Market Street, San Francisco. Established March 18, 1890. Incorporated April 5, 1890. Membership, 370. Date of meeting, second Tuesday, monthly. Date of annual exhibition, no set time. *President*, Percy Neymann, Ph.D.; *Secretary*, Clifford B. Rushmer.
- CAMERA CLUB**—New York. Headquarters, 121 West 68th Street. Established by consolidation of Society of Amateur Photographers and New York Camera Club in April, 1896. Incorporated May 7, 1896. Membership, 200. Date of annual meeting, first Thursday after the first Monday in January. *Secretary*, Monroe W. Tingley.
- CAMERA CLUB OF CINCINNATI**—Cincinnati, Ohio. Headquarters, Seventh and Walnut Streets. Established February 26, 1913. Date of meetings, 1st and 16th of each month, except when said dates fall on Sunday; then on the following Monday. *President*, Charles H. Partington; *Secretary and Treasurer*, G. A. Ginter.

- CAMERA CLUB OF DETROIT**—Detroit, Mich. Organized April, 1915. Membership, 45. Annual meeting for election of officers first Monday in October. *President*, Otto H. Linstead; *Vice-President*, Cecil H. Taylor; *Secretary-Treasurer*, Philip M. C. Armstrong; *Board members at large*, Dr. Oscar E. Fischer and Herman Gabriel.
- CAMERA CLUB OF HARTFORD**—Hartford, Conn. Membership, 15. *President*, Dr. Frederic S. Crossfield, 75 Pratt Street; *Vice-President*, Clayton P. Chamberlain; *Corresponding Secretary*, Euguene D. Field; *Treasurer*, A. L. Chase; *Secretary*, Mr. Charles R. Nason, 20 Madison Street.
- CAMERA CLUB OF THE TWENTY-THIRD STREET BRANCH**. Y. M. C. A.—New York. Headquarters, 23d Street Y. M. C. A. Established June 3, 1904. Membership, 65. Date of business meetings, second Tuesday in each month. *President*, Wm. J. Guy; *Acting Secretary*, Ernest A. Heckler, 215 West 23d Street; *Treasurer*, F. W. Grunwald. Date of annual exhibition, usually in January. No fixed date.
- "CAMERADS"**—New Brunswick, N. J. Headquarters, corner Church and George Streets. Established April 24, 1890. *Secretary*, Harvey Iredell, D.D.S., Lock Box 34, New Brunswick.
- CAMERA CRAFT CLUB**—Steubenville, Ohio. Established March 28, 1913. Regular meetings last Friday of each month. *President*, Miss Elinor J. Neidengard; *Vice-President*, Miss Margaret E. Fisher; *Secretary and Treasurer*, Charles E. McKee, 1011 Wilson Avenue.
- CAMERA CRAFTSMEN**. *Director*, Roy C. Burckes, 249 School Street, Winter Hill, Mass.
- CAMERA PICTORIALISTS OF LOS ANGELES**—Los Angeles, Cal. Headquarters, 415 Blanchard Building. Association formed for strictly pictorial work. Membership limited to 15. Meetings first Wednesday of month. *Director*, Louis Fleckenstein; *Correspondent*, David J. Sheahan.
- CAPITAL CAMERA CLUB, INC.**—Washington, D. C., 712 11th Street, N. W. Founded May 1, 1891. Annual meeting, third Thursday in May. *President*, George H. Macdonald; *Vice-President*, Charles A. Baker; *Secretary*, Rutland D. Beard; *Treasurer*, Thos. B. Gardner; *Librarian*, Mrs. W. B. McDevitt. Date of annual exhibition, May.
- CHICAGO CAMERA CLUB**—Chicago, Ill. Headquarters, 329 Plymouth Court. Established February 14, 1904. Incorporated February 19, 1904. Date of meetings, every Thursday. *President*, Jos. Simons; *Vice-President*, F. T. Farrell; *Secretary*, H. P. Parker, 329 Plymouth Court.
- CHICAGO PHOTO FELLOWS**—Chicago, Ill. Organized September 8, 1909. Membership, 8. *Correspondent*, F. M. Tuckerman, 1109 Railway Exchange, Chicago.
- CITY HALL CAMERA CLUB**—Los Angeles, Cal. Headquarters, Room 505 Hosfield Building. Organized May 25, 1914. Membership, 24. *Correspondent*, W. C. Sawyer.
- CLEVELAND PHOTOGRAPHIC SOCIETY**—Cleveland, Ohio, 412 Superior Avenue, N. W. Established June 7, 1913. Permanent organization effected at meeting of June 18. Meetings every Wednesday. *Chairman*, Dr. H. B. Van Tress; *Secretary-Treasurer*, Stephen Domonkos.
- COLUMBIA PHOTOGRAPHIC SOCIETY**—Philadelphia, Pa. Headquarters, 2526 North Broad Street, Philadelphia. Established 1889. Incorporated July 3, 1894. Membership, 75. Date of meetings, first Monday of each month, business meeting; other Mondays, lectures or demonstrations. *President*, Dr. James S. Gallagher; *Vice-President*, H. E. Cassel; *Secretary*, C. F. Davis, 701 Eldridge Avenue, West Collingswood, N. J.; *Treasurer*, H. E. Abbott, 6807 No. 11th Street, Oak Lane, Philadelphia, Pa.
- DUNKIRK RADIO AND CAMERA CLUB**—Dunkirk, N. Y. Amateur Photographers and Amateur Wireless Operators eligible. *President*, John H. Clarke; *Secretary*, Francis X. Dotterweich, 523 Dove Street.
- DAGUERRE CAMERA CLUB**—Headquarters, Harbert, Mich. Established 1893. Membership, 20. Date of meetings, first Monday of each month. *President*, F. Blish; *Secretary*, Wells Sizer, Harbert.
- ELMIRA CAMERA CLUB**—Elmira, N. Y. Headquarters, 116 Baldwin Street, Elmira. Established 1902. Membership, 30. *President*, George C. Wheeler; *Secretary-Treasurer*, Seely Stage, 706 Columbia Street.
- ELYSIAN CAMERA CLUB**—Hoboken, N. J. Headquarters, 307 Washington Street. Established 1902. Date of meetings, second Friday of each month. Membership, 50. *President*, Martin S. Crane; *Vice-President*, Adolph Geiger; *Treasurer*, Julius Nelson; *Secretary*, William F. Nelson, 590 Boulevard East, Weehawken, N. J.
- ESSEX CAMERA CLUB**—Newark, N. J. Headquarters, 872 Broad Street, Newark, N. J. Organized July, 1899. Membership, 40. Date of meetings, fourth Tuesday of every month. *President*, George A. Hardy; *Secretary*, L. F. Gebhardt, South 11th Street.
- GRAND RAPIDS CAMERA CLUB**—Grand Rapids, Mich. Headquarters, 2 Central Place, N. E. Established 1899. Meetings every Thursday evening from September to June. *President*, Dr. Rawson; *Vice-President*, John L. Benjamin; *Treasurer*, Harvey E. Barnes; *Secretary*, Harriet M. Goodrich, 143 Waverly Avenue, Grand Rapids, Mich.

- INTERNATIONAL PHOTOGRAPHIC ASSOCIATION**—San Francisco, Cal. Founded 1908. *President*, F. B. Hinman, 1369 So. Washington Street, Denver, Col.; *Chief Album Director*, J. H. Winchell, R. F. D. No. 2, Painesville, Ohio; *General Secretary*, Fayette J. Clute, 413-415 Claus Spreckels Building, San Francisco; *Stereoscopic Album Director*, James B. Warner, 413-415 Claus Spreckels Building, San Francisco, Cal.; *Director Post Card Division*, Charles M. Smythe, 1160 Detroit Street, Denver, Col.; *Director Lantern-Slide Division*, George E. Moulthropo, Bristol, Conn.; *Secretary Lantern-Slide Division*, Edward F. Cowles, 11 Oak Street, Bristol, Conn. *The State Secretaries, Alabama*—Richard Hines, Jr., Barton Academy Building, Mobile. *Alaska*—P. S. Hunt, Valdez. *California*—W. E. Thomson, 3211 School Street, Fruitvale, Cal. *Colorado*—O. E. Aultman, Plested Building, Trinidad. *Connecticut*—George E. Moulthropo, Bristol. *Florida*—Capt. E. S. Coutant, Box 73, Stuart. *Georgia*—L. O. Surles, P. O. Box 434, Cuthbert. *Idaho*—Eugene Clifford, Weippe. *Illinois*—George A. Price, 802 West Park Street, Urbana. *Indiana*—H. E. Bishop, 1706 College Avenue, Indianapolis. *Iowa*—C. W. Parker, Mapleton. *Kansas*—H. E. High, Box 232, Elsworth. *Maryland*—E. G. Hopper, 218 East 20th Street, Baltimore. *Massachusetts*—John Mardon, 161 Summer Street, Boston. *Michigan*—W. E. Ziegenfuss, M.D., 327 West Hancock Avenue, Detroit. *Minnesota*—Leonard A. Williams, St. Cloud. *Mississippi*—George W. Askew, Jr., 211 34th Avenue, Meridan. *Missouri*—Wharton Schooler, R. F. D. No. 2, Eolia. *Nebraska*—Miss Lou P. Tillotson, 822 South 38th Street, Omaha. *New Hampshire*—Mrs. A. Leonora Kellogg, Box 224, Londonderry. *New York*—Charles F. Rice, P. O. Box 517, Mamaroneck. *New Jersey*—Burton H. Albee, 103 Union Street, Hackensack. *North Dakota*—Jas. A. Van Kleeck, 619 Second Avenue, North Fargo. *Ohio*—J. H. Winchell, R. F. D. No. 2, Painesville. *Pennsylvania*—L. A. Sueary, 2822 Espy Avenue, Pittsburg. *South Dakota*—C. B. Bolles, L. B., 351, Aberdeen. *Texas*—J. B. Oheim, P. O. Drawer M, Henrietta. *Utah*—John C. Swenson, A.B., Provo. *West Virginia*—William E. Monroe, Box 298, Point Pleasant.
- INTER-CITY CAMERA CLUB, PRINT EXCHANGE**—Headquarters, Portland, Me. Membership, 8 cities. *Chairman*, Carl A. Jordan, 7 Wilney Avenue, Portland, Me.
- JAMESTOWN CAMERA CLUB**—Jamestown, N. Y. Established 1907. Headquarters, Chadakoin Building, Jamestown, N. Y. Membership, 18. Meetings, second Tuesday of month. *President*, C. O. Hultgren; *Vice-President*, C. Southwick; *Treasurer*, E. H. Sample; *Secretary*, L. Miller, 108 Buffalo Street.
- KANSAS CITY CAMERA CLUB**—Kansas City, Mo. *President*, Val B. Minton; *Vice-President*, Dr. A. H. Cordier; *Secretary-Treasurer*, Dr. Maclay Lyon, Suite 501 Bryant Building. Club meets second Thursday of each month. Annual exhibition in March.
- LANTERN AND LENS GILD OF WOMEN PHOTOGRAPHERS.**—Headquarters, 10 South 18th Street, Philadelphia, Pa. Established 1909. Membership, 60. Meetings, every Wednesday. *Dean of Gild*, Mrs. Walter Murphy; *Deans*, Mrs. M. W. Wiltse, Miss Helen Holden; *Stewards*, Miss M. W. Little; *Clerk*, Miss M. L. Bodine.
- LITTLE ROCK CAMERA CLUB**—Little Rock, Ark. Organized in spring, 1916. Limited membership. Advanced amateurs. Meets every two weeks. *President*, Roderick Gallie, 411 West 13th Street; *Secretary*, Bert R. Kime, 511½ Main Street.
- MISSOURI CAMERA CLUB**—St. Louis, Mo. Club Rooms, 5035 Delmar Avenue. Organized November, 1903. Meetings, second and fourth Tuesday. *President*, W. C. Crouse; *Treasurer*, Gilbert Goldman; *Secretary*, Roland M. Homer, 5085 Von Versen Avenue, St. Louis.
- MONTREAL AMATEUR ATHLETIC ASSOCIATION CAMERA CLUB**—Montreal, Canada. Headquarters, M. A. A. Building, 250 Peel Street. Organized May 1, 1906. *President*, Gordon K. Miller; *Vice-President*, P. F. Calcutt; *Treasurer*, R. E. Melville; *Secretary*, E. W. de Cordova, 603 Shaughnessy Building, Montreal.
- NEWARK CAMERA CLUB**—59 Mechanic Street, Newark, N. J. Organized 1888. Incorporated 1910. *President*, Lysander E. Wright; *Vice-President*, Robert B. M. Taylor; *Treasurer*, L. Wright, Jr.; *Secretary*, Albert F. Quinlin. Membership, 90. Meetings, second and fourth Mondays in each month.
- NEW BRITAIN CAMERA CLUB**—Organized 1892. *President*, U. G. Dillon; *Vice-President*, John A. Lewis; *Secretary and Treasurer*, Paul A. Stahl, 104 So. Burrirt Street, New Britain, Conn. Meets second and fourth Tuesdays, 173 Main Street.
- NEW HAVEN CAMERA CLUB**—739 Chapel Street. Organized 1911. Membership, 75. *President*, Bernard H. Walden; *Vice-President*, J. M. Walton; *Secretary*, F. R. Lawrence; *Treasurer*, H. D. Vincent. Meetings held every Thursday. Business meetings, first Thursday in the month.
- OAK PARK CAMERA CLUB**—Oak Park, Ill. Organized February, 1915. Membership, 18. *President*, G. F. Chase; *Vice-President*, F. D. Manchester; *Secretary*, Mabel Morey; *Treasurer*, A. R. Hanson.

- ORANGE CAMERA CLUB—Orange, N. J. Headquarters, 222 Main Street. Established March 21, 1892. Incorporated May 19, 1893. Membership, 100. Date of meetings, first and third Saturdays of each month, except July, August and September. *President*, Stephen S. Johnson; *Secretary*, Lindley W. Bode, 222 Main Street, Orange, N. J.
- OREGON CAMERA CLUB—Portland, Ore., 51 Washington Building. Established 1895. Incorporated 1903. Membership, 150. Date of meetings, second Tuesday in January. *President*, C. F. Richardson; *Vice-President*, J. A. Leas; *Secretary-Treasurer*, J. J. Tyrrell. Date of annual exhibition, early spring.
- PHOTOGRAPHIC CLUB OF BALTIMORE CITY—Baltimore, Md. Headquarters, Maryland Academy of Sciences Building, 105 West Franklin Street. Established 1885. Incorporated 1890. Membership, active, 50. Date of meetings, every Tuesday. *President*, J. Swing Willis, 514 Forrest Road, Roland Park, Md.; *Secretary*, C. C. Knobloch, 20 N. Luzerne Avenue, Baltimore, Md. Date of annual exhibition, March.
- PHOTO FELLOWS OF THE WORLD—*Dean*, Sigismund Blumann, 3217 Davis Street, Fruitvale, Cal. Membership by invitation only.
- PHOTOGRAPHIC SOCIETY OF PHILADELPHIA—Philadelphia, Pa. Headquarters, 1615-1617 Sansom Street. Established November, 1862. Incorporated April 24, 1885. Membership, 130. Date of meetings: Members, second Wednesday; visitors, third Wednesday. *President*, Henry P. Baily; *Secretary*, John Martin Hammond, 1615 Sansom Street; *Treasurer*, Harold F. A. Starr. Date of members' annual exhibition, February. Members annual exhibit vacation work, in all media—November.
- PHOTO SECESSION—New York, N. Y. Headquarters and Galleries, 291 Fifth Avenue. Continuous exhibitions November-April. *Director*, Alfred Stieglitz.
- PITTSBURGH-ACADEMY OF SCIENCE AND ART (PHOTOGRAPHIC SECTION)—Pittsburgh, Pa. Headquarters, Carnegie Institute, Schenley Park. Organized January 23, 1900. Membership, 100. Meetings, second and fourth Tuesdays of each month at Carnegie Institute. *President*, O. C. Reiter, 2424 Penn Avenue; *Vice-President*, Rev. David R. Breed; *Secretary-Treasurer*, C. E. Beeson, 19th floor, Frick Building, Pittsburgh, Pa.; *Lantern-Slide Director*, W. A. Dick, 910 Chislett Street; *Print Director*, S. A. Martin, 923 Chislett Street. Annual salon, Carnegie Art Gallery, March. Address all communications to C. E. Beeson, *Secretary*, 1900 Frick Building, Pittsburgh, Pa.
- PITTSBURGH CAMERA CLUB—Pittsburgh, Pa. Established December, 1910. Membership, 25. *President*, Robert L. Sleeth, Jr.; *Treasurer*, William McK. Ewart, 2524 Center Avenue; *Secretary*, Charles W. Douth, Crafton, Pa.
- PITTSBURGH SALON OF PHOTOGRAPHIC ART—Pittsburgh, Pa. Under auspices of Photographic Section of the Academy of Science and Art. Membership consists of the leading pictorialists in the United States. *Secretary*, O. C. Reiter, 2424 Pennsylvania Avenue, Pittsburgh, Pa.
- PORTLAND CAMERA CLUB PHOTOGRAPHIC SECTION OF THE PORTLAND SOCIETY OF ART—Portland, Me. Headquarters, L. D. M. Sweat Memorial, Spring, corner High Street. Established 1899. Membership, 90. Date of meetings, every Monday evening. *President*, George E. Fogg; *Vice-President*, William B. Bradford; *Secretary*, E. Roy Monroe. Date of annual exhibition, in March.
- POSTAL PHOTOGRAPHIC CLUB—Headquarters, Washington, D. C. Established December, 1888. Membership, 40. Date of meetings, no regular meeting. *President*, Charles E. Fairman; *Secretary*, Ernest L. Crandall, 1752 Euclid, N. W., Washington, D. C. Albums circulate among members monthly, except August and September.
- PROVIDENCE CAMERA CLUB—Providence, R. I. Established 1883. Incorporated 1889. Headquarters, Commercial Building, 55 Eddy Street. Total membership, 100. Date of meetings, second Saturday of each month. *President*, H. Ladd Walford; *Vice-President*, Ernest F. Salisbury; *Secretary*, C. W. Morrill, 55 Eddy Street; *Treasurer*, G. Frederick Bohl.
- ROCHESTER CAMERA CLUB—Rochester, N. Y. Headquarters, 123 West Main Street. *Board of Trustees*—Chairman, Jas. A. Kipp; Arthur Wygant, E. Shantz, W. J. Reddin; *Secretary-Treasurer*, Edw. A. Carroll, 417 Monroe Avenue, Rochester, N. Y.
- SPRINGFIELD PHOTOGRAPHIC SOCIETY—Springfield, Mass. Meets in Central High School the second Wednesdays of every month except July and August. *President*, Dr. Albert J. Treichler; *Vice-President*, Arthur P. Irving; *Secretary*, P. M. Tainter, Mittineague, Mass.; *Treasurer*, Mrs. K. A. Burdette; *Custodian*, Wm. A. Quigley; *Chairman of Executive Committee*, J. P. Bishop.
- SOUTHERN CALIFORNIA CAMERA CLUB—Los Angeles, Cal. Studio, dark-rooms, exhibition gallery, etc., occupies entire top floor Lyceum Building. Organized May 20, 1915. Club meets every Thursday, 8 p. m. *President*, T. K. Adlard; *Vice-President*, C. T. Dodds; *Treasurer*, C. L. Hogan; *Secretary*, Hal G. Hall, Station "C," Box 104, Los Angeles.
- ST. LAWRENCE CAMERA CLUB—Ogdensburg, N. Y. Headquarters, 74 Caroline Street. Established 1900. Membership, 8. Date of meetings, at the call of the *Secretary*. *President*, Arthur L. Jameson; *Secretary*, John N. Brown, 74 Caroline Street.

- ST. LOUIS CAMERA CLUB**—St. Louis, Mo. Organized February 12, 1914. Devoted to the interest and advancement of the art of photography. Meetings every second and fourth Thursday at 8 p. m.; Central Public Library, 13th and Oliver Streets. *President*, Oscar C. Kuehn; *Vice-President*, Hector Updike; *Secretary*, S. F. Duekworth, 2156 Allen Avenue.
- TOLEDO CAMERA CLUB**—Toledo, Ohio. Member of the American Federation. Headquarters, Museum of Art. Meet second Wednesday of month. *President*, John T. Murphy; *Vice-President*, R. E. Ferguson; *Secretary*, Harry A. Webb, 1017 Prouty Avenue; *Treasurer*, M. W. Chapin.
- TORONTO CAMERA CLUB**—Toronto, Canada. In affiliation with the Royal Photographic Society of Great Britain. Established 1887. Incorporated 1893. Headquarters, 2 Gould Street. Membership, 200. Date of meetings, every Monday, from October to April, inclusive. *President*, E. W. Hendrick; *Secretary-Treasurer*, Robt. J. Morrow, 2 Gould Street. Date of annual exhibition, March, April or May.
- TRINIDAD CAMERA CLUB**—Trinidad, Col. Established April 21, 1906. Meetings second Wednesday of every month at O. E. Aultman's Studio. Monthly competitions. *President*, W. L. Crouch; *Vice-President*, Wilber Davis; *Secretary and Treasurer*, W. Dearden, 717 Colorado Avenue. Member of American Lantern Slide Interchange.
- WASHINGTON Y. M. C. A. CAMERA CLUB**—Washington, D. C. Headquarters, Central Y. M. C. A. Building. Membership, 55. *President*, J. K. Schofield; *Vice-President and Treasurer*, W. L. Vetter; *Secretary*, F. H. Eldred.
- WESLEY CAMERA CLUB**—Headquarters, Bell Theatre Building. Organized April 6, 1912. Meeting the first Monday of each month. *President*, W. A. Drewelow; *Vice-President*, Halvor Flom; *Secretary and Treasurer*, Lawrence Burke (Wesley, Iowa).
- YONKERS CAMERA CLUB**—Yonkers, N. Y. Headquarters, Hollywood Inn Building. *President*, W. R. Cronk; *Vice-President*, H. B. Spreckels; *Secretary*, A. E. Cope; *Librarian*, C. B. Carling; *Trustees*, Dr. S. L. Jeffery, Wm. Beck, Wm. S. Mitchell.



GILL & SON.

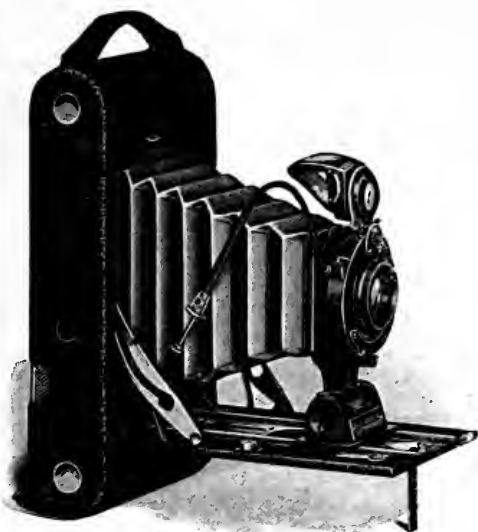

*New even to the size of  
the pictures it makes.*

## The No. 2<sup>c</sup> Autographic Kodak Junior

(picture proportions  
2 $\frac{7}{8}$  x 4 $\frac{7}{8}$  inches)

The picture proportions pleasing in themselves, are such as to naturally emphasize the real picture. The resulting print is filled with picture.

Compactness characteristic of any Kodak is emphasized in this new model. There's room for it—and to spare—in the ordinary pocket and yet unusually thin construction has been secured with no compromise to completeness of equipment.

Of course it's autographic.

### THE PRICE.

No 2C Autographic Kodak Junior, with meniscus achromatic lens and Kodak Ball Bearing shutter,	\$12.00
Ditto, with Rapid Rectilinear lens, - - -	14.00
Ditto, with Kodak Anastigmat, <i>f</i> .7.7 lens, - -	19.00

EASTMAN KODAK COMPANY,

*At your dealers'.*

ROCHESTER, N. Y., *The Kodak City.*

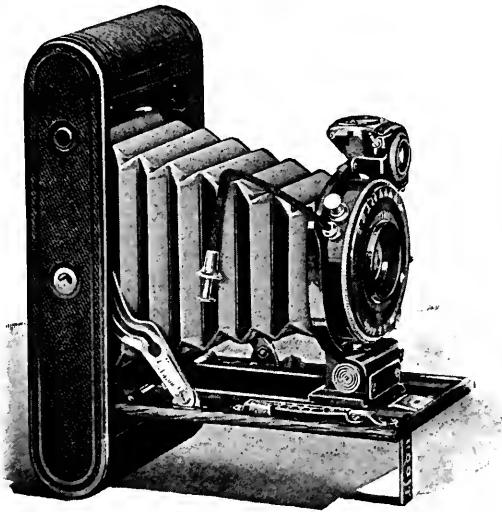

*Here is true  
KODAK  
efficiency.*

**Y**OU can make a photograph with a pin hole for a lens. Cheap cameras have small lenses, with correspondingly small openings—but fast enough for snap-shots in a good light. As you get into the better grades, the lenses grow larger.

True efficiency requires a lens of fairly long focus that will work with a large opening—a big lens in a big shutter. That's the kind you find in the No. 1 Autographic Kodak *Special*. And with it a shutter that has a speed up to  $1/300$  of a second. *Here is true efficiency with nothing sacrificed to mere littleness.*

And in every detail of construction and finish this little camera shows evidence of having come from the factory where honest workmanship has become a habit.

No. 1 Autographic Kodak Special, for  $2\frac{1}{4} \times 3\frac{1}{4}$  pictures, Optimo shutter with variable speeds from one second to  $1/300$  of a second, also time action, with Kodak Anastigmat lens  $f.6.3$ , focal length  $4\frac{3}{8}$  inches. Price, \$40.00.

**EASTMAN KODAK COMPANY,**

*At your dealers'.*

ROCHESTER, N. Y., *The Kodak City.*



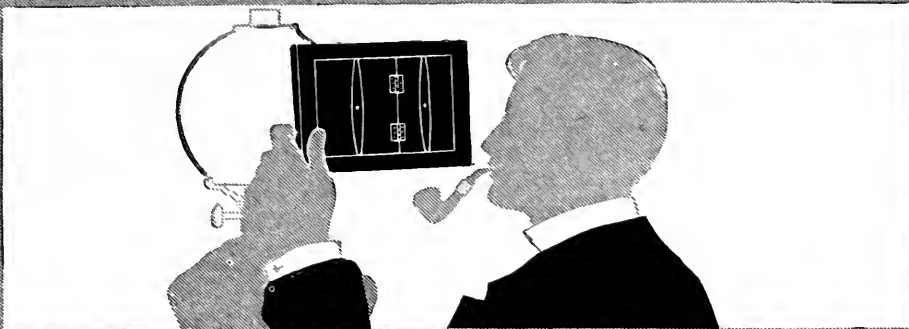

## Prints by Gaslight

The versatility of

# VELOX

With three degrees of contrast, six grades and a variety of surfaces to choose from, the amateur need go no further than Velox to best fit *every* negative.

NEPERA DIVISION,  
EASTMAN KODAK COMPANY,  
ROCHESTER, N. Y., *The Kodak City.*

*At your dealer's.*

# SEED PLATES

From the extremely rapid Seed Graflex Plate to the slow Seed 23 and Seed Process, the Seed Plate line is complete—a Seed Plate for every need.

SEED GRAFLEX, the most rapid Seed Plate ever produced, yields the best possible results from short exposures and may be developed to the degree of contrast desired by the press photographer without danger of fogging.

SEED 30 GILT EDGE is the ideal plate for portraiture—it has exceptional speed with nothing sacrificed in quality, gradation or fineness of grain. Seed 27 Gilt Edge and Seed 26X are also excellent for portraiture but are not so rapid as the Seed 30.

SEED L ORTHO, NON-HALATION L ORTHO, C ORTHO AND PANCHROMATIC are color sensitive plates used by the commercial photographer and for general outdoor and interior work, the Panchromatic being sensitive to the entire spectrum.

SEED 23 is a very slow plate with wide latitude, while the slower Seed Process is especially suited for line work. There is also the Seed Lantern Slide Plate and, for the Roentgenologist, the Seed X-Ray Plate, and they all have the uniformity and dependability that have made Seed Plates the Standard of Quality.

*It's a Seed Plate you need.*

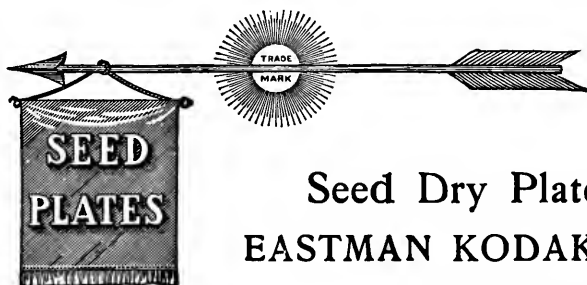

*All dealer's.*

Seed Dry Plate Division,  
EASTMAN KODAK COMPANY,  
ROCHESTER, N. Y.

*“Every Amateur His Own Finishing Department.”*

The combination of the Kodak Film Tank and the Kodak Amateur Printer enables any amateur to develop his films and make his prints conveniently, expeditiously *and well*—with a big gain in photographic pleasure.

## The Kodak Film Tank



provides the means for developing film at any time—in broad daylight if you will—and insures at the outset, results that could not be improved upon.

The price ranges from \$2.75 to \$8.00 according to size.

---

## The Kodak Amateur Printer

embodies all the latest ideas in photographic printing including an automatic masking device. For his own needs, the amateur could not find a more efficient printer,—there isn't one. Supplied complete (except Mazda Lamp) including red bulb and cord and socket. Price, \$6.00.

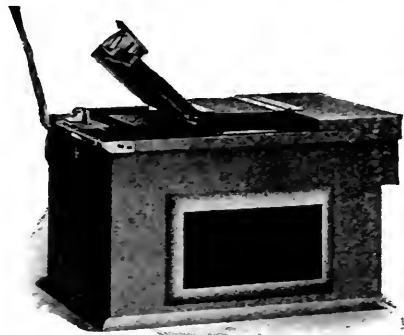

EASTMAN KODAK COMPANY,  
ROCHESTER, N. Y.

*At your dealer's.*

*The Quality of*

# EASTMAN PORTRAIT FILM

can only be designated as *plus* because it is not comparable with that of any other sensitive material. It is the quality that goes beyond known standards and sets a mark of its own. And that mark can never be reached by a plate because of the very nature of the glass support.

Eastman Portrait Film has the fine grain, the long scale of gradation and great latitude of the best portrait plate made, the Seed 30, *plus* all the quality that practical freedom from halation imparts to the portrait negative, *plus* lightness, flexibility, compactness and other physical qualities that are thoroughly appreciated by a constantly growing army of film users.

EASTMAN KODAK COMPANY,  
ROCHESTER, N. Y.

*All dealers'.*

Of equal importance to you in securing results and to us in manufacturing sensitive material is the certainty of a standard strength and purity of the chemicals used.

Specify E. K. Co. Tested Chemicals and be certain of your results.



*Look for this seal on the  
container.*

EASTMAN KODAK COMPANY,  
ROCHESTER N. Y.

*All Dealers'.*

# Wratten Safelight Lamps

Afford the greatest volume of light by which a plate may be handled with a definite degree of safety because they transmit only the light to which the plate is least sensitive. The lamps are constructed only for electricity on the indirect or reflected light principle, giving a soft light which relieves eye strain. The safe-



lights are spectroscopically tested to insure the absorption of the necessary colors and the transmission of as much safe light as possible. Series 2 Safelight is furnished with lamp unless otherwise specified.

Wratten Safelight Lamp No. 1, as above, - - - - -	\$9.00
Do., No. 2, without slide for white light, - - - - -	6.00
Series 1 Safelight, for all plates not color-sensitive, 8 x 10, - - - - -	1.00
Series 2 Safelight, for Orthochromatic plates, 8 x 10, - - - - -	1.00
Series 3 Safelight, for Panchromatic plates, 8 x 10, - - - - -	1.00



# Kodak Safelight Lamp

This is an adaptation of the Wratten Safelight Lamps, smaller in size but similar in construction. The light from the globe in the upper portion of the lamp falls upon a curved white-enamelled surface which reflects it through the safelight in the front of the lamp. The lamp is furnished with electric socket cord and plug but without electric globe. Series 2 Safelight furnished with lamp.

Kodak Safelight Lamp, complete as above, - - - - -	\$3.00
Extra Safelights, 5 x 7 any series, each, - - - - -	.50

**EASTMAN KODAK COMPANY,**  
ROCHESTER, N. Y.

*All dealers'.*

Duplicate the small  
print in larger size on

ARTURA  
CARBON  
BLACK

The effect as well as the quality  
of the contact print is retained.

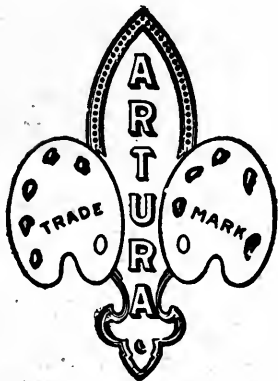

ARTURA DIVISION,  
EASTMAN KODAK COMPANY,  
ROCHESTER, N. Y.

*All Dealers':*

# ROUGH & CALDWELL COMPANY

ARTISTS AND DESIGNERS OF

## Photographic Backgrounds and Accessories



No. 6579

Size	Price	Price with 7 ft. Oil Ext.
6 x 8....	\$12.00....	\$16.00
8 x 8....	16.00....	21.60

Oil floor extension 10 cents sq. foot. If painted on sail cloth add 10 cents sq. foot.



We are in a position to supply any design of background or accessory on short notice. Write for new styles *just out*. All dealers handle our goods. When ordering from your dealer insist on ROUGH & CALDWELL goods, the standard of quality for years. All our grounds are stenciled on the back with the design shown.

**Rough & Caldwell Co., 57 E. 9th St., New York**





Mr. Amateur ???

Have You Got What  
You WANT?

---

HERE'S YOUR CHANCE

Before Buying or Selling, consult our  
BARGAIN LIST—a postal will bring it to you

---

We have the Largest Assortment of New and  
Second Hand Cameras and Lenses in New York

The Date of our Establishment  
Speaks for Itself—1890

Ica, Butcher and other Foreign Cameras  
Always on Hand

New York Camera  
Exchange

109 Fulton Street

NEW YORK

J. H. ANDREWS, Proprietor.

# ARDEN (Slip-in)

Café Cover enclosing Café Card  
 Steel Gray Cover enclosing Ash Gray Card  
 Koko Brown Cover enclosing Koko Brown Card

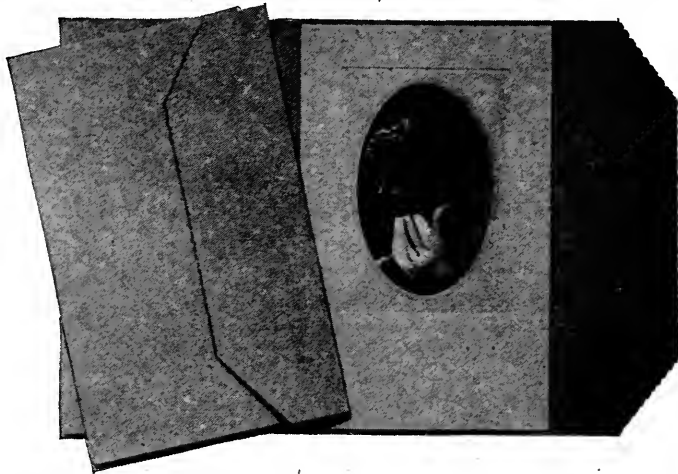

For delicate tones and conservative style, this will appeal to all who are making pictures for the best class of patrons. All the colors have been carefully selected to give the best possible effects. The absence of ornamentation that is gaudy will particularly please. The insert has a two-tint border around the opening and is plate marked around the tint. The large flap is deckled beautifully and more artistically done than in the set conventional folder.

	Folder Closed	Oval Opening	For Picture	Per 100
46 O	6 $\frac{3}{4}$ x 11	3 $\frac{5}{8}$ x 5 $\frac{5}{8}$	4 x 6	\$6.00
57 O	7 $\frac{1}{2}$ x 11 $\frac{1}{2}$	4 $\frac{1}{2}$ x 6 $\frac{1}{2}$	5 x 7	8.00
70 O	9 $\frac{3}{4}$ x 14 $\frac{1}{2}$	6 $\frac{1}{2}$ x 9 $\frac{1}{2}$	7 x 10	12.00

### Square Opening.

46 S	7 x 11	3 $\frac{5}{8}$ x 5 $\frac{5}{8}$	4 x 6	\$6.00
57 S	7 $\frac{1}{2}$ x 11 $\frac{1}{2}$	4 $\frac{1}{2}$ x 6 $\frac{1}{2}$	5 x 7	8.00
70 S	9 $\frac{3}{4}$ x 14 $\frac{1}{2}$	6 $\frac{1}{2}$ x 9 $\frac{1}{2}$	7 x 10	12.00

Send for samples of our new corner pocket folders. Something different and practical.

**GEORGE MURPHY, Inc.**

57 East Ninth Street

New York

Send for our Special Mount Catalogue

# **S**TANDARD BLOTTING *Chemically Pure*

SOLD BY

Leading Photo Supply Dealers Everywhere

ASK FOR IT AND TAKE NO OTHER  
IF YOU WANT THE BEST



MADE ESPECIALLY FOR

**PHOTOGRAPHIC PURPOSES**  
**ABSOLUTELY LINTLESS**



CARRIED IN STOCK IN  
19 x 24—80, 100, 120 AND 140 POUND  
500 SHEETS TO REAM



MADE BY

**Standard Paper Manufacturing Co.**  
RICHMOND, VA., U. S. A.



# The Improved Percy King Light Controller

(PATENTED MARCH 12, 1907)



The Controller does not lengthen the exposure. It simply tones down the direct light at any point desired. It should be placed between the subject and the light and as near the subject as possible without cutting into the size of the picture being made.

The Controller in use weighs only 18 pounds, can be easily carried about the studio, and is adjustable up to 7 feet high, to suit any effect desired.

It is made in several styles fitted with different fabrics, which are used according to the character of the work desired, viz., black opaque fabric to cut off all the light; white fabric to diffuse strong light; and yellow fabric, to counteract freckles and skin blemishes, producing more uniform effects and harmonious lights, thus saving much retouching.

	Price
No. 1 King Light Controller, Black Canton Flannel, Screens and Apron.....	\$9.00
No. 2 King Light Controller, White Cheese Cloth, Screens and Apron.....	9.00
No. 3 King Light Controller, Yellow Cheese Cloth, Screens and Apron.....	9.00
No. 4 King Light Controller, Black Felt Cloth, Screens and Apron.....	13.50
No. 5 King Light Controller, Black Velveteen, Screens and Apron.....	13.50

**GEORGE MURPHY, Inc. Ret. Dept. 57 East 9th Street, New York City**

**ROUGH & CALDWELL COMPANY**  
ARTISTS AND DESIGNERS OF  
PHOTOGRAPHIC BACKGROUNDS AND ACCESSORIES



**No. 3076. Combination Balustrade Seat. Price, \$27.50.**

Consisting of Pedestal to which seat is attached, curved lines and relief back; also additional steps forming many combinations.

Dimensions: Entire length, 4 ft.

Seat 3 ft. long, 19 in. high from floor, 12 in. deep.

Balustrade—Opposite side of seat 28 in. high.

Post 3 ft. high, 10 in. in front, 20 in. deep.

*Send for catalogue—New designs*

**ROUGH & CALDWELL CO., 57 E. 9th ST., NEW YORK**

Strength, Brilliancy and  
Gradation Give

# HAMMER PLATES

## FIRST PLACE

Speed and Reliability enable them to hold it

Hammer's Special Extra Fast (red label) and Extra Fast (blue label) Plates for field and studio work.

Hammer's Extra Fast Orthochromatic and D. C. Orthochromatic Plates for color values.



*Hammer's Little Book  
"A Short Talk on Negative  
Making"  
Mailed Free.*

**HAMMER DRY PLATE COMPANY**

Ohio Avenue and Miami Street : : ST. LOUIS, MO.

# Diamidophenol

Quick, clean, economical developer. Works rapidly without fogging and is absolutely stainless. Made in America by Americans. Always in stock for immediate delivery. All our merchandise is equal to imported, or better.

Manufacturers and Jobbers **HERMAN & HERMAN, Inc.**  
Chemicals, Colors and Intermediates 6 Church Street, New York City



Made by an amateur with one No. 12 Actino

## Pleasing Portraits In the Home

may be easily made by you with the aid of

### ACTINO Flash Cartridges

These are put up in measured exposure sizes, insuring you correctly timed negatives. All your exposures made with them are instantaneous.

You can so easily and satisfactorily illuminate any indoor subjects with Actino cartridges that the use of them will more than double the pleasure you derive from your camera.

Get a supply today from your dealer with a free copy of our instructive illustrated booklet, "Flashlight Photography."

**J. H. SMITH & SONS CO., 3536 Cottage Grove Ave., Chicago**

## For All Cameras, Plates or Films

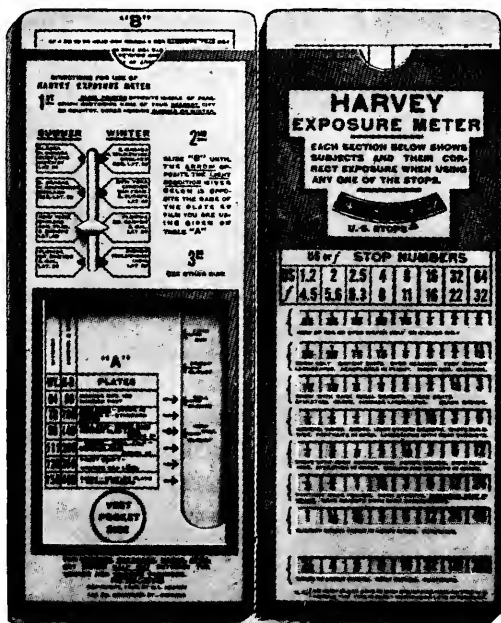

The only Meter that gives Exposures for *all Classes* of Outdoor Subjects and for all Stops *without making calculations* or re-setting.

Slide B gives Exposures for Stopping Motion, *Interiors, Night Photography, and Paget and Autochrom Color Plates.*

The Meter is adapted not only to all general Cameras, but also is the best to use for *Motion Picture* work and *Cirkut Cameras.*

Costs no more than two spoiled Roll Films. Made of Celluloid, 2 5/8 x 6 1/4". Price \$1.00.

**Send for Circular.**

*Ask your dealer or write to the manufacturer.*

**GEO. L. HARVEY**  
[105 S. Dearborn St. CHICAGO



# CRAMER PLATES and COLOR FILTERS

for  
DEPENDABLE QUALITY  
in

LANDSCAPE  
PORTRAIT  
GENRE  
COMMERCIAL

and all other photographic work  
where

EXCELLENCE IN NEGATIVE IMAGE

Is Imperative or Desirable

G. CRAMER DRY PLATE CO., St. Louis, Mo.

Leading  
PHOTOGRAPHERS  
Everywhere

are adopting tools of

Greatest Efficiency for accurate detail Coloring—  
Blocking Out—Spotting, etc.

## PAASCHE AIR-BRUSHES



A Paasche Artist or Photographer's  
Complete Outfit in Operation.

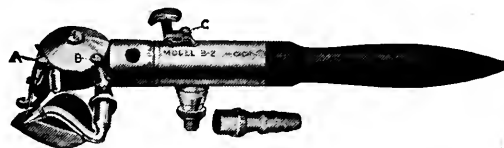

Fill the most exacting re-  
quirements.

Permits the use of colors  
(all kinds) such as Water  
Colors, Retouch Colors,  
Op aques, Whites, Lamp  
Black, W. P. Inks, etc.

Don't throw away Imperfect  
Prints.

Make Attractive Tinted Sam-  
ples of them for your Display  
Case.

One Dainty Tinted Photo  
with each dozen will Increase  
Business.

Write us today for particu-  
lars.

*Paasche Air Brush Co.*

77 Madison Terminal Bldg.,  
Chicago.



## MINIATURE POLYGON AND POCKET CAMERAS

with RIETZSCHEL LINEARS F:4.5

(Eight element cemented symmetrical anastigmats)  
**An Ideal Combination, not equalled by any other outfit on the market.**

The CAMERAS, small though they be, possess all movements found hitherto in large cameras only and some more practical ones too.

The LINEARS are acknowledged to be the finest anastigmats on the market—cutting sharp to corners, with unusual brilliancy and depth of field, and transmitting a greater amount of light than any other F:4.5 lenses.

**MEYER CAMERA & INSTRUMENT CO., Inc.**

31 East Twenty-seventh Street

NEW YORK

Importers of Highest Grade Cameras, Lenses and Photographic Specialties



TRADE MARK

## SELTONA

The World's Finest Photographic Paper

BARNET PLATES

550 H. & D. Fastest in the World

Steadman's Aabameter, \$1.00

J. L. LEWIS, 522 Sixth Ave., N.Y.



BRANCHES:  
 Chicago, London

## HIGGINS' PHOTO MOUNTER PASTE

The kind you are sure to use  
 with continuous satisfaction

*At Dealers Generally*

Chas. M. Higgins & Co., Mfrs.,

271 Ninth Street, Brooklyn, N. Y.

## REFLEX CAMERA CO.,

NEWARK, N. J.

MANUFACTURERS OF

**High Speed and Reflecting Cameras**

*Send for Catalog*

# STEREO SMITH TRADE MARK AMMETOL

REG. U. S. LETTERS PAT.  
(POLYMETHYLPARAMIDOPHENOL-SULPHATE)

The one American made developing agent that has become the by-word of professional and amateur photographers.

AMMETOL is in a class by itself. No Caustic Soda required. Send today for further information.

**Brooklyn Chemical Laboratories**  
Brooklyn, New York

“MADE IN U. S. A.”

Something New!  
Of Interest to All! **SNOW WHITE FLUID**  
For Marking Prints, Mounts, Leaves of Albums or for Opaque

*Will not rub off*  
*Will not powder*



*Always serviceable*  
*Simply add water*

½ OUNCE PASTE

Highest endorsements won from leading photographer journals and famous photographers.

### SPECIAL INDUCEMENTS!

Until April 1st, 1917, each package shipped from my laboratory will be accompanied with selected pens, pen cleanser and simple directions to insure success. Also the booklet:

**Snow White Border Designs for Photo Albums**  
AT DEALERS GENERALLY

or by prepaid return mail on receipt of 25c in coin or stamps from the manufacturer.

J. V. JOHNSTON

P. O. 578

Rochester, N. Y.

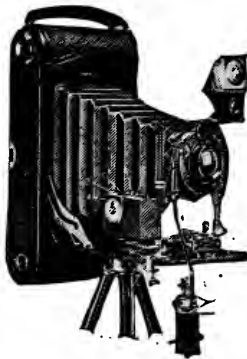

## Just What You Have Been Looking For! THE PHOTOTAKER

The Automatic Operator for Cameras and Kodaks

Allows everyone in the picture, or permits a person to take his own picture—makes your pictures complete. Not merely a "shutter tripper," but an automatic operator, but little larger than a dollar watch, time or instantaneous exposure, signal just before exposure is made, and attaches to most any make of camera or Kodak in a few seconds. Most practical device out. At your dealer's, or by mail, \$2.50. Add 10 cents for postage in foreign countries.

Southwestern distributing branch,  
The Phototaker Co., Dep. C, Ardmore, Okla., U. S. A.

The Original American Paramidophenol Developer is

# KATHOL

Patented October 26, 1915.

Use it according to our patented formulae. IT GIVES BY FAR THE BEST RESULTS.

KATHOL MANUFACTURING COMPANY, Inc., 230th St. & Riverdale Ave.. New York City

# SAVE

25% to 50%  
on Any Camera

Operating as one of the biggest camera supply houses in the Middle West, we are prepared to supply you immediately with just the camera or lens you want. Our Bargain Bulletin explains everything. It shows in figures how much we actually save you. Write for it *today*.



David  
Stern Co.

1047 N. Madison  
St.  
CHICAGO, ILL.

Have YOU Tried It?

# PROBUS

A PERMANENT BLACK FINISH  
Acid, Alkali and Water-proof

For coating all kinds of trays, tanks, sinks, shelves, fixing boxes, and the like; for painting darkroom walls and bad floors, and for water-proofing home-made trays, it is ideal.

INDISPENSABLE IN DARKROOM  
AND WORKROOM

Used and recommended by the leading  
Photographic Studios, Commercial Finishers,  
Motion Picture and X-Ray Laboratories

Manufactured expressly for photographic purposes. Easily applied, dries quickly. No dirt—no muss. Half-pint trial tin costing only 35 cents will save you almost as many dollars.

Pint 65c Quart \$1.00 Half Gal. \$1.65  
One Gallon \$3.00 Five Gallons \$13.50

ALL DEALERS

WOLFF & DOLAN  
MANUFACTURERS

220 Post St. San Francisco

This space reserved by  
Abe Cohen's Exchange, Inc.  
114 Park Row, New York City

# **DON'T TAKE YOUR CAMERA OUT-OF-DOORS!**

**For Fear**

It will cost you a Dollar.

**You'll Shoot Something**

in Nature and you'll want to subscribe for

**THE GUIDE TO NATURE**

It's a dollar a year, but we'll "start easy" on  
four months' trial for 25c. Address:

**THE GUIDE TO NATURE  
ArcAdiA: Sound Beach, Conn.**

# COLONA

NON-CURLING

# PAPERS

Standardized as to Surfaces, Grades and Exposures

GIVE YOUR PRINTS  
COLONA DISTINCTION

*The ideal paper for*

The Amateur  
The Commercial Photographer  
The Studio

GRADES: CONTRAST, NORMAL, SOFT  
SURFACES: SEMIMATT, MATT, GLOSSY  
WEIGHT: SINGLE AND DOUBLE

MAY BE DRIED WITH HEAT

SAMPLES FREE ON REQUEST



The Sussex Photo  
Supply Company  
Newton, N. J.

# A Complete Line of Quality Cameras At Prices Within the Reach of All

That's the story of the Rexo Line in a few words.

## REXO CAMERAS

are made in a variety of styles and sizes, from the simple Rexoette box cameras selling from \$2.00 to \$5.00, to the De Luxe Rexo Specials, selling up to \$66.00 for the finest optical equipment obtainable. Between these extremes there are many low and standard priced folding cameras from \$6.00 to \$25.00.

The No. 3A Rexo (illustrated) is a master camera, incorporating all the unique Rexo Features, such as the Masking Finder, U-Shaped Standard, Wide Track, Rack and Pinion, New Concealed Spool Holding Device and Film Aligning Back.

Send for the 1916 Rexo Book, describing the complete Rexo Amateur Line.

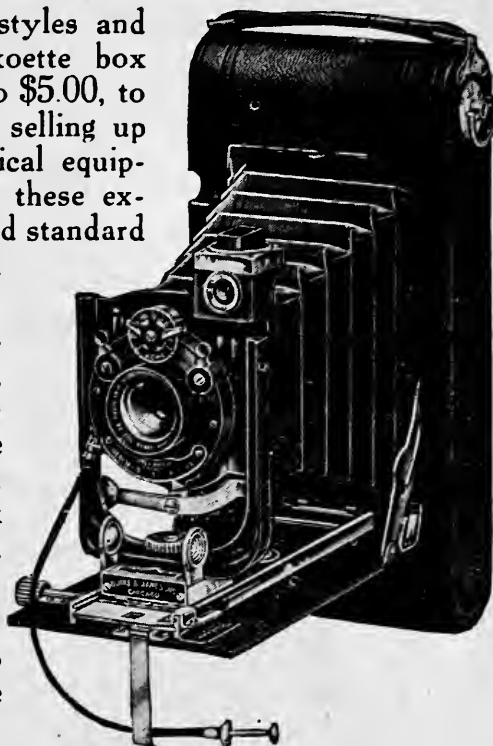

We are sole wholesale agents for

The Guaranteed  
Developer

**FREDOL**  
A DEVELOPING AGENT FOR  
PAPERS, FILMS and PLATES

Universal In Its  
Adaptability

Fredol has proved itself to be the most excellent all round developing agent placed on the market in recent years.

### Note the Prices

1 ounce bottle	-	\$0.85	½ pound bottle	-	\$ 6 25
4 ounce bottle	-	3.15	1 pound bottle	-	12.00

Live, progressive dealers wanted in all parts of the world.

Factory  
240 E. Ontario St.  
CHICAGO

**Burke & James Inc**

Eastern Branch  
225 Fifth Avenue  
NEW YORK

Sole Wholesale Agents for Voigtlander & Sohn

# For Perfect Pictures Load Your Camera With



## Extremely Rapid — Non-Curling — Orthochromatic

Rexo Record Film possesses in the fullest degree all the qualities necessary to the production of perfect negatives, and in addition possesses a special advantage not offered by any other film on the market.

### The Recording Feature

Ample space is provided between each negative for writing thereon full data relating to each picture. The data is written with ordinary black ink. The writing is done when the film is dry, and forms a permanent, legible record.

The next essential in securing good pictures is the use of good paper which will give the best print from every negative.

### Make Your Prints On

The Guaranteed  
Developing  
Paper



A Grade  
For Every Class  
of Negative

### Marvelous Latitude in Exposure and Development

These features eliminate wasted prints and make REXO the logical choice of the amateur, commercial and professional photographers. REXO is uniform in quality and produces pictures marked by beautiful gradations, purity of the highlights and transparency of the shadows. It is easy to make good prints on REXO.

**Rexo Cameras, Film, Paper and Photo-Supplies are  
Manufactured By**



**Burke & James Inc**  
240-258 E. Ontario Street :: CHICAGO



Eastern Branch :: 225 Fifth Avenue :: New York City

**Live, Progressive Dealers Wanted in all parts of the World**



# WYNNE INFALLIBLE HUNTER EXPOSURE METER

The Wynne Infallible Hunter Meter has been specially designed to attain the maximum of simplicity, convenience and efficiency, with a minimum diameter, and thickness of case—the case being only one-quarter of an inch in thickness. It is beautifully made in the best Solid Nickel and opens automatically by pressure of the small knob on the pendant.



On the right hand side of the open case is the Actinometer with standard tints and sensitive paper. On the left hand side of the case are the two scales for the calculation of the exposures. The top dial is interchangeable so that scales according to either F, U S or specially divided scales for Autochrome exposures can be instantly substituted for one another.

When ordering, please specify which style of scale is desired (F or U S)

Hunter Meter . . . . .	\$2.75
Extra packages Sensitive paper . . . . .	.25
Pocket case of tan leather . . . . .	.50
Set of top and bottom dials . . . . .	.50
Top scale only, F or U S . . . . .	.25
Autochrome Scale and instruction book . . . . .	.35
Extra book of instructions . . . . .	.10
Extra speed card . . . . .	.10

## The Weighmeter

The Latest  
Photographic Discovery

Indispensable to photographers, chemists, physicians, or anyone engaged in weighing chemicals.

The Weighmeter instantly indicates by one turn of the dial exactly what weights are to be used on the scale for any given formula. Saves time, trouble, annoyance and opportunities for errors in making the usual computations. Beautifully printed in two colors on ivory celluloid, and of just the right size to fit the vest pocket.

Price 50c., postpaid.

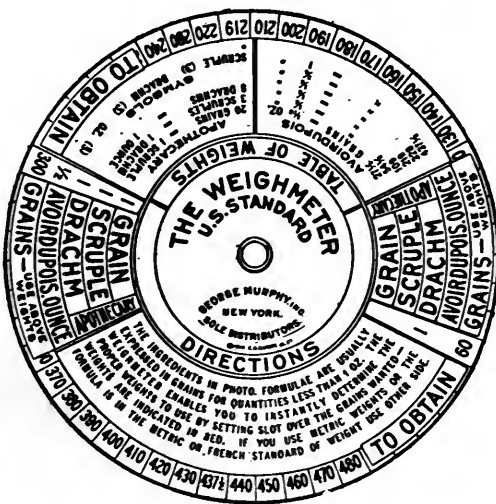

## GEORGE MURPHY, Inc.

Retail Department

57 East Ninth Street

New York

Send for Post-paid Mail-Order Cash Catalogue

The Finest Anastigmat Lens Is  
**The HOLOSTIGMAT**

*Made in 4 Series*

ALL OF WHICH ARE CONVERTIBLE

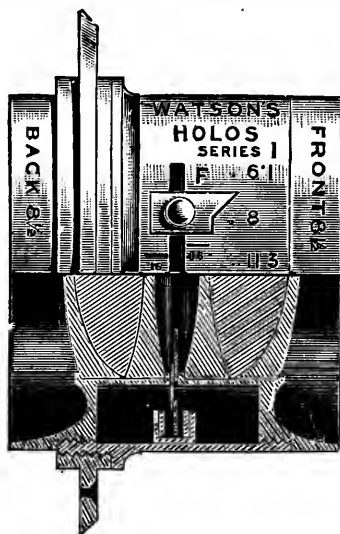

Series 1 A aperture f4.6—f4.9  
for high speed work and portraits.

Series 1 aperture f6.1—f6.5  
for Landscape, Architecture and general  
outdoor work.

Series 111 aperture f9.5  
for Copying, Reproduction and Photo  
mechanical work.

Wide Angle aperture f11  
for wide angle work and interiors.

The Holostigmat is perfectly corrected for color photography. Kew Observatory tests have proved that the Holostigmat passes a larger percentage of incident light than any other type, and is actually more rapid than many other lenses of nominally larger aperture.

Full list of the above lenses will be sent post free on application to the manufacturers.

**W. WATSON & SONS, LIMITED**

*Opticians to His Majesty's Government*

313, High Holborn

London, England

Established 1837



# ENSIGN

"The Hall Mark of Quality"

## CAMERAS

We point it out to you as the name given to a superior line of Cameras.

### Vest-Pocket, Folding, Reflex and Box Models

Equipped with selected lenses from the simple single Achromatic to the high grade Anastigmats. Constructed from the best materials worked out from efficient design.

**Special Notice**—See the Ensign Popular Reflex equipped with original Carl Zeiss Tessar lens F. 4.5 at \$90.00. Other models from \$2.25 up.

### AT YOUR DEALER OR DIRECT

Ensign Catalog FREE on Request

## G. GENNERT

24-26 E. 13th St.,  
NEW YORK

Chicago

Los Angeles

San Francisco





# IMPERIAL PLATES

## NONE BETTER BEHIND THE LENS

*A Special Grade for Every Known Purpose*

**FLASHLIGHTS**—Ultra rapid, adapted to dark days and press photography.

**SPECIAL SENSITIVE**—Brilliant, sparkling, a plate for general photography of exceptional latitude.

**LANTERN SLIDE**—for Pictorial Work.

ORTHOCHROME  
NON-FILTER  
SOVEREIGN  
VELONA  
RADIO FLASH

ORDINARY FINE GAIN  
PROCESS  
BACKED  
DUO NON  
X-RAY

**At Your Dealer**

Send for Imperial Booklet explaining every grade

### G. GENNERT

New York    Chicago    Los Angeles    San Francisco



# Ensign Films— BETTER THAN EVER

*Non-Curling  
Orthochromatic  
Double Instantaneous*

Keeping qualities ex-  
celled by none.

Rapid fine grained  
emulsion assures you  
fully time negatives  
during the fall and  
winter.

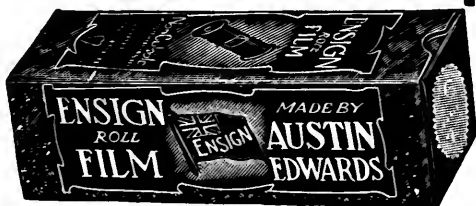

# THE Sylvar ANASTIGMAT LENS

*Ser III F-6.8*

RAPID—SYMMETRICAL

Made from the famous Jena  
Glass now not procurable  
owing to the war.

NO RAISE IN PRICE



You can secure a Sylvar and  
improve your work at the  
same old list as long as the  
present stock lasts.

No. 2  $3\frac{1}{4} \times 4\frac{1}{4}$  cells only \$20.00

No. 3A  $3\frac{1}{4} \times 5\frac{1}{2}$  " " \$23.00

Send your camera to us to  
be fitted.

## G. GENNERT

24-26 E. 13th St.  
NEW YORK

320 S. Wabash Ave.  
CHICAGO

455 S. Olive St.  
LOS ANGELES

693 Mission St., SAN FRANCISCO

# The Montauk Retouching Desk

**A Practical Desk  
at a Moderate Price**



Especially designed and adaptable to the work of the advanced amateur. Supplied with kits for  $3\frac{1}{4} \times 4\frac{1}{4}$ ,  $4 \times 5$  and  $5 \times 7$  negatives. Holds them in just the correct position to receive the reflected light. Adjustable to any position.

**Price \$1.75**

## Montauk Printing Masks For White Margins

Made from selected opaque black paper, with clean-cut edges. Each package contains 15 assorted masks. They add attractiveness and interest to your prints. Used by those who know. All sizes, one price; from  $2\frac{1}{4} \times 3\frac{1}{4}$  to  $5 \times 7$ .

**Price 15c per package**

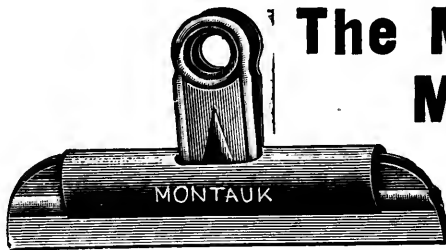

## The Montauk Metal Film Clip

**Indispensable for  
Handling Films**

Brass heavily nickel-plated; made with strong spring which holds the film securely while handling during development and hanging up to dry. Non-corrosive in developer or fixing bath.

**Per pair 25c**

**G. GENNERT,** New York, Chicago, Los Angeles, San Francisco

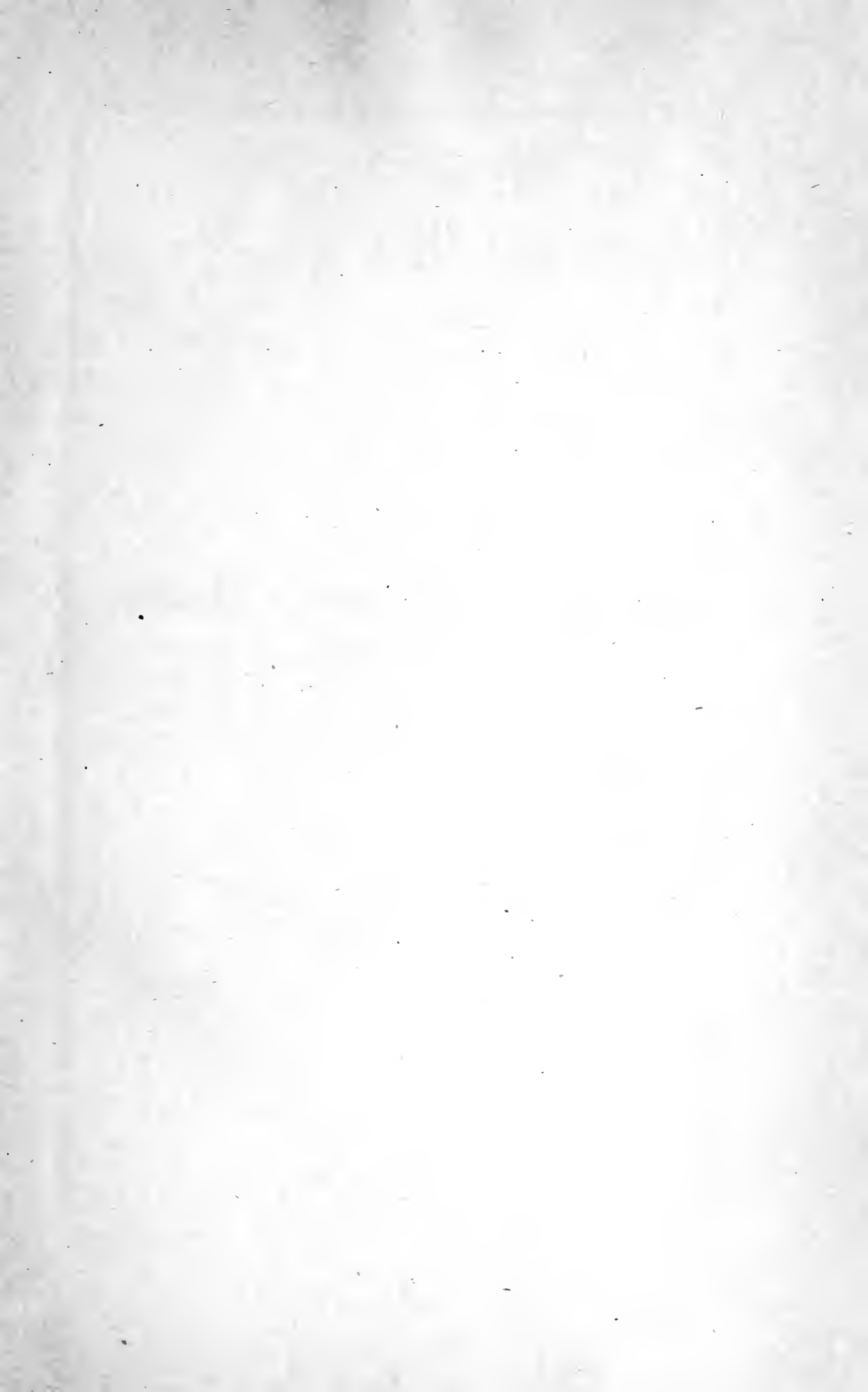

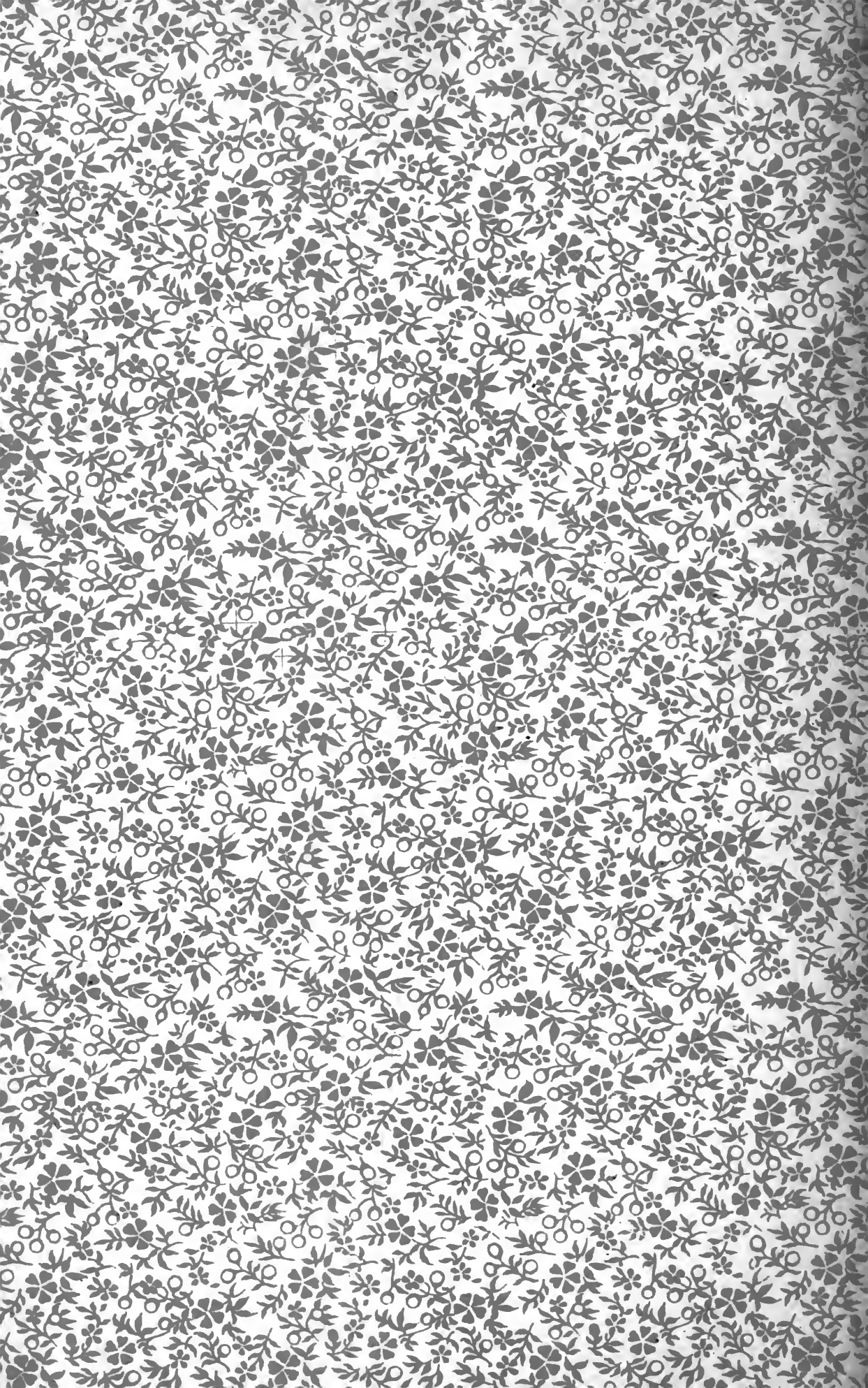



BRIGHAM YOUNG UNIVERSITY



**3 1197 21750 7851**

